



ANTI-ICE TIERED SYSTEM

Service and Parts Manual



MONROE TRUCK EQUIPMENT
1051 W. 7th Street
Monroe, WI 53566
Phone: 608-328-8127
Fax: 608-329-8488
Website: www.monroetruck.com

05052345
8/19/2014

TABLE OF CONTENTS

SAFETY INSTRUCTIONS	Page 2
INTRODUCTION	Page 3-4
OPERATING INSTRUCTIONS	Page 5-7
MAINTENANCE INSTRUCTIONS	Page 8-9
FILLING INSTRUCTIONS	Page 10-11
INSTALLATION INSTRUCTIONS	Page 12-15
GENERAL INFORMATION	Page 16
REPLACEMENT PARTS	Page 17-52
HOW TO ORDER PARTS	Page 53
RETURN POLICY	Page 53
WARRANTY INFORMATION	Page 59

WARNING:

Some anti-icing/de-icing/pre-wetting chemicals and/or their vapors are **NOT** compatible with 304 stainless steel and can cause damage to 304 stainless steel tanks and tank welds. Storing those types of chemicals in 304SS tanks is not recommended and may void the tank's warranty. Monroe Snow & Ice Control assumes no responsibility for damage to 304SS tanks caused by incompatible chemicals being used for anti-icing/de-icing/pre-wetting applications. Monroe Snow & Ice Control recommends that you contact your chemical supplier to check your anti-icing/de-icing/pre-wetting chemical's compatibility with 304SS prior to loading into tanks.

SAFETY INSTRUCTIONS

- Read all installation, safety and maintenance instructions completely before operating this equipment
- Keep all personnel clear of moving parts while equipment is being operated.
- Do not operate equipment in need of maintenance! Repair immediately!
- While operating this equipment, use common sense, use caution, be alert and be safety-conscious.



! DANGER

AVOID HIGH-PRESSURE FLUIDS

Escaping fluid under pressure can penetrate the skin causing serious injury.

Avoid the hazard by relieving pressure before disconnecting hydraulic or other lines. Tighten all connections before applying pressure.

Search for leaks with a piece of cardboard. Protect hands and body from high pressure fluids.

If an accident occurs, see a doctor immediately. Any fluid injected into the skin must be surgically removed within a few hours or gangrene may result.

!!!! WARNING !!!!

NOTICE: MONROE SNOW AND ICE CONTROL - Does not Manufacture, sell or distribute chemicals of any type. If there is ever a question concerning the proper application of a particular chemical or the safety of the chemicals use, contact the manufacturer of the chemical. Follow safe handling and storage precautions listed by chemical manufacturer. Never purchase or use chemicals that are not in their original containers or any chemical with uncertain origin.

This equipment is for use with chemicals approved by STATE OR FEDERAL Agencies governing the use of chemical being used.



! WARNING

**Flying debris.
Stay clear and wear
eye protection.
Failure to heed will
result in serious injury.**

IF DEFACTED - ORDER PART NO. 05051407

Monroe Truck Equipment, Inc. Introduction

This state of the art Monroe Snow and Ice Control Anti-Ice unit consists of an in cab microprocessor based control console, a corrosion resistant storage tank, a hydraulically driven 210 GPM centrifugal pump, system control plumbing, and a spray boom system to distribute the product. The application rate is automatically regulated by the control console. By reading the vehicle ground speed (via the included speed sensor), and using the desired application rate (as input by the operator), the console will calculate the required output, and govern the flow accordingly. The flow of product is controlled by one of two methods: By controlling the output of the product pump directly by controlling it's speed, or by controlling an inline butterfly valve. The method used will be determined by the system configuration. However, standard practice is to control the pump directly. Liquid output will therefore increase and decrease as the vehicle speeds up and slows down, respectively. The operator need only select the desired application rate and enable the lane(s) in which to apply. This unit is capable of self-loading/ unloading, and agitation of the product in the tank, all using the on-board pump. The plumbing is also configured to allow the unit to be filled using an off-board pump without having to force the product through the on-board pump.

This system comes standard as a skid mounted unit, designed for easy, one-person loading and unloading. This allows the system to be removed from the truck, allowing the dump body to be used for hauling once again, in just a matter of minutes.

This unit is available with a number of spray boom configurations each tailored to a different application. The two most common configurations are covered in this manual. They are:

The Monroe Snow & Ice Control 3 Lane Dual Tier Anti-Ice System.

This anti-icing unit is designed to optimize low rate/ low speed applications, while still allowing high rate/ high-speed application. By utilizing a dual tier, six spray boom arrangement, the low volume tier, with low volume spray nozzles, can remain filled at low GPM rates, which makes full side lane penetration possible. At high GPM rates, both tiers are operating. The second, or "high volume", tier is automatically enabled by the in cab microprocessor based control console at a preset GPM value. This value is determined initially by the system capacity, and may later be modified as determined by user preference and experience.

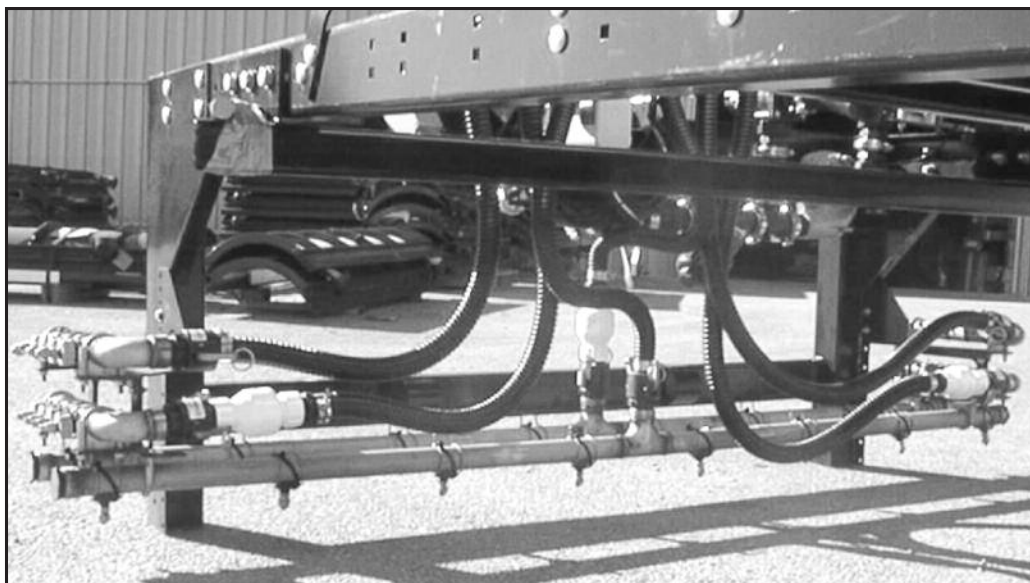

The Monroe Snow & Ice Control 3 Lane Single Tier Anti-Ice System.

This anti-icing unit is designed to optimize higher rate/ higher-speed applications and utilizes a single tier, three spray boom arrangement. This system, using higher capacity nozzles, allows the use of higher application rates through fewer nozzles at lower pressure, resulting in less atomization and over spray. This translates into better snow and ice penetration and/or dry pavement traction.

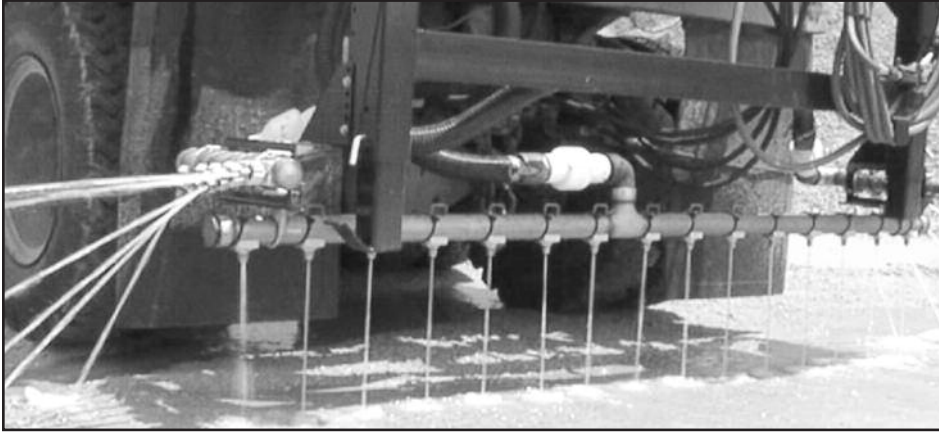

(2" High Capacity Booms Shown)

System Capacity:

The plumbing components (e.g. boom assemblies and plumbing kits) of an anti-ice system are specified according to the system capacity. Table 1 shows the system capacity required for a single lane operating at different application rates and ground speeds. Each lane of a multiple lane system must have the same capacity in order for the system to apply accurately. *For this reason it is important, when replacing nozzles, to use nozzles with the same GPM capacity as the others on the boom.*

By using Table 1, it is possible to determine the maximum speed and application rate for your system. When calculating the maximum operating parameters of your system, it is necessary to use the component of the system with the **smallest** capacity. This will typically be the boom assembly.

For instance, if the boom assembly provided with your system is rated at 32 GPM/ lane, even though the standard plumbing kit is rated at 150GPM total, the operating parameters should be calculated for 32 GPM/ lane maximum.

For example, if an operator wanted to apply 30 gal/ lane mile at 40 MPH, to 3 lanes, we can see in Table 1 that the boom assemblies must have at least a 20 GPM/ lane capacity. Therefore, the plumbing kit must have a capacity of 60 GPM or greater if all lanes are going to be operating at the same time. These parameters are well within the 150 GPM capacity of the standard plumbing kit.

An example where the plumbing kit is the limiting component would be when applying to all 3 lanes using a 56 GPM/ lane, 3 lane boom assembly on a dual tier system. In this example, the plumbing kit with 150 GPM total would be supplying 50 GPM/ lane. Therefore the maximum operating parameters for this system should be calculated for 50 GPM/ lane maximum.

By looking at Table 1, we can see that the maximum parameters calculated at 50 GPM/ lane are: 60 gal/ lane mile at 50 MPH or 50 gal/ lane mile at 60 MPH.

System capacity required (GPM) for single lane application at various rates and speeds.

Gallons per lane mile ↑	60	5.0	10.0	15.0	20.0	25.0	30.0	35.0	40.0	45.0	50.0	55.0	60.0	Typical application range
	55	4.6	9.2	13.8	18.3	22.9	27.5	32.1	36.7	41.3	45.8	50.4	55.0	
	50	4.2	8.3	12.5	16.7	20.8	25.0	29.2	33.3	37.5	41.7	45.8	50.0	
	45	3.8	7.5	11.3	15.0	18.8	22.5	26.3	30.0	33.8	37.5	41.3	45.0	
	40	3.3	6.7	10.0	13.3	16.7	20.0	23.3	26.7	30.0	33.3	36.7	40.0	
	35	2.9	5.8	8.8	11.7	14.6	17.5	20.4	23.3	26.3	29.2	32.1	35.0	
	30	2.5	5.0	7.5	10.0	12.5	15.0	17.5	20.0	22.5	25.0	27.5	30.0	
	25	2.1	4.2	6.3	8.3	10.4	12.5	14.6	16.7	18.8	20.8	22.9	25.0	
	20	1.7	3.3	5.0	6.7	8.3	10.0	11.7	13.3	15.0	16.7	18.3	20.0	
	15	1.3	2.5	3.8	5.0	6.3	7.5	8.8	10.0	11.3	12.5	13.8	15.0	
	10	0.8	1.7	2.5	3.3	4.2	5.0	5.8	6.7	7.5	8.3	9.2	10.0	
	5	0.42	0.83	1.25	1.67	2.08	2.5	2.92	3.33	3.75	4.17	4.58	5.0	
		5	10	15	20	25	30	35	40	45	50	55	60	

Ground speed in MPH →

For multiple lane system capacities, multiply the single lane capacity by the total number of lanes required.

OPERATING INSTRUCTIONS

Regardless of the boom configuration, the system operation procedures and the control plumbing (see chart on page 6) remain the same.

- Check chart on page 6 and ensure that all valves are in their normal operating positions.
- Ensure that the control console has been programmed with the desired application rates (See manual for information on programming) and that the console key has been removed.
- Turn control console “POWER” to “ON” (DLA336) or to “GR/LI” (DCS710)
- Enable the hydraulics to the anti-ice unit.
- Assuming that the tank has been loaded with product, enter the total number of gallons of product in the tank into the console. (See manual for procedure) This step is required in order to use the low-level alarms, the low-level shut off feature, and to monitor the amount of product remaining in the tank from inside the cab. (This step can be performed at any time prior to application)
- Before reaching the area of application, select the desired application rate using the “RATE” knob.
- When arriving at the area of application, turn “ON” the desired lane switches and the “MASTER” switch. This can be done either by selecting the lanes first and turning “ON” the “MASTER” switch; or by leaving the “MASTER” switch “ON” and turning “ON” the desired lane switches at the time of application. Experience and user preference will determine this.
- When leaving the area of application, turn “OFF” the lane switches and/or the “MASTER” switch.

Valve letter and main function			Chart for Standard System Plumbing (00071389)	
A-Three way valve for Self-Fill/Main Tank Outlet	B-Return Line For Agitation/ Tank Fill	C-Bulk Fill/ Self-unload	Result	
Valve position				
TOWARD LINE TO TANK	OFF	OFF	Normal material application mode. Material is discharged through spray nozzles as determined by the operator using in-cab controls to turn on electric lane valves.	
TOWARD LINE TO TANK	ON	OFF	Agitation mode. With the console "Master" switch "On" and the lane valves "Off", product can be circulated in the tank by selecting rate "M" and holding the "INC/DEC" lever to "INC" to increase pump speed.	
TOWARD LINE TO TANK	ON	ON	Fill from the ground base pump station mode (Bulk Fill). *CAUTION* When filling using a high volume pump, it is recommended that the manhole be opened to avoid building excess pressure in the tank.	
TOWARD LINE TO STORAGE	ON	OFF	Self load mode. With the console "Master" switch "On" and the lane valves "Off", product can be loaded into the tank by selecting rate "M" and holding the "INC/DEC" lever to "INC" to increase pump speed.	
TOWARD LINE TO TANK	OFF	ON	Self unload mode. With the console "Master" switch "On" and the lane valves "Off", product can be unloaded from the tank by selecting rate "M" and holding the "INC/DEC" lever to "INC" to increase pump speed.	

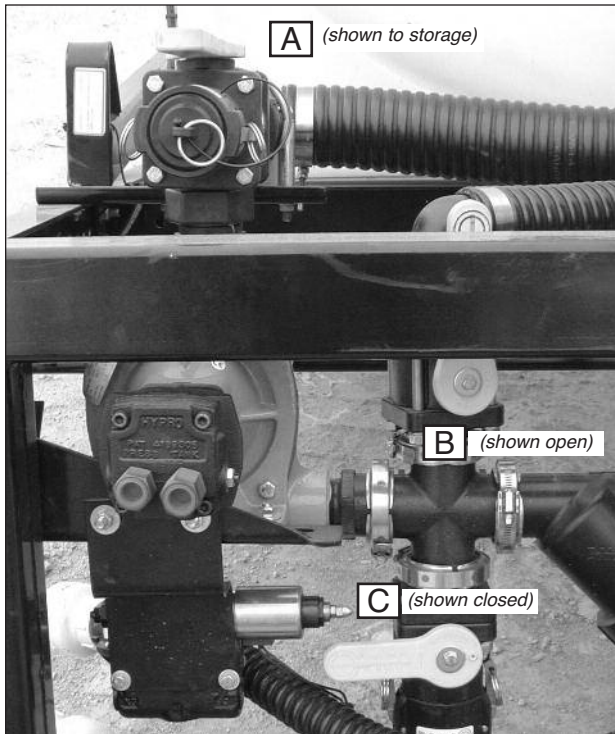

Self-Load Mode

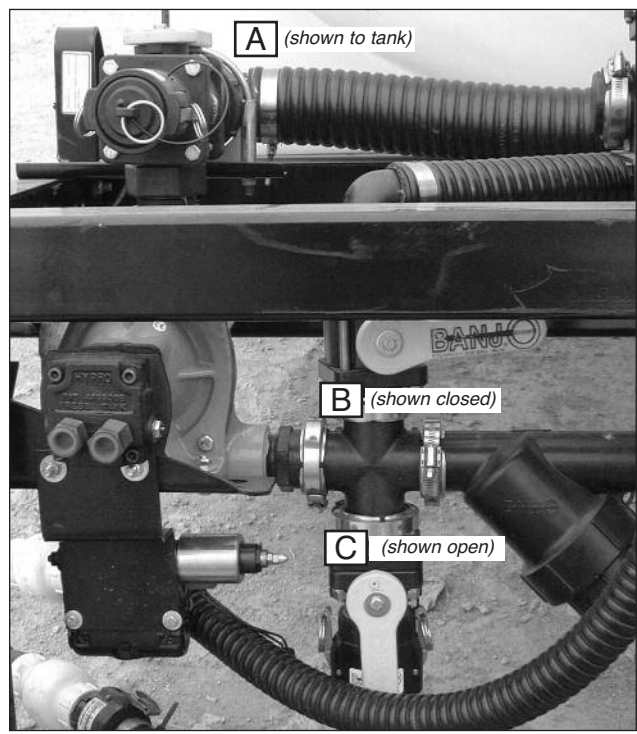

Self-Unload Mode

Please see chart on previous page for callout descriptions.

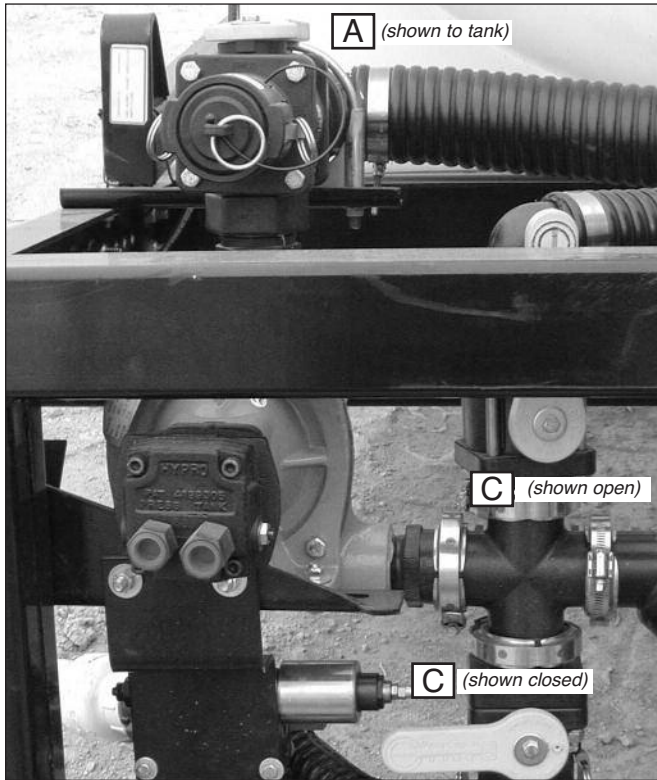

Agitate Mode

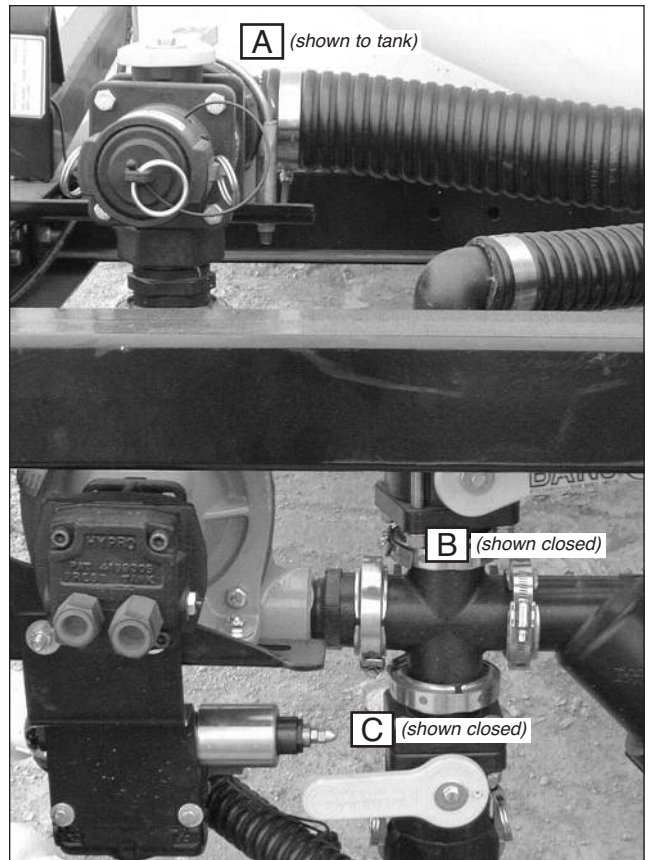

Operation Mode

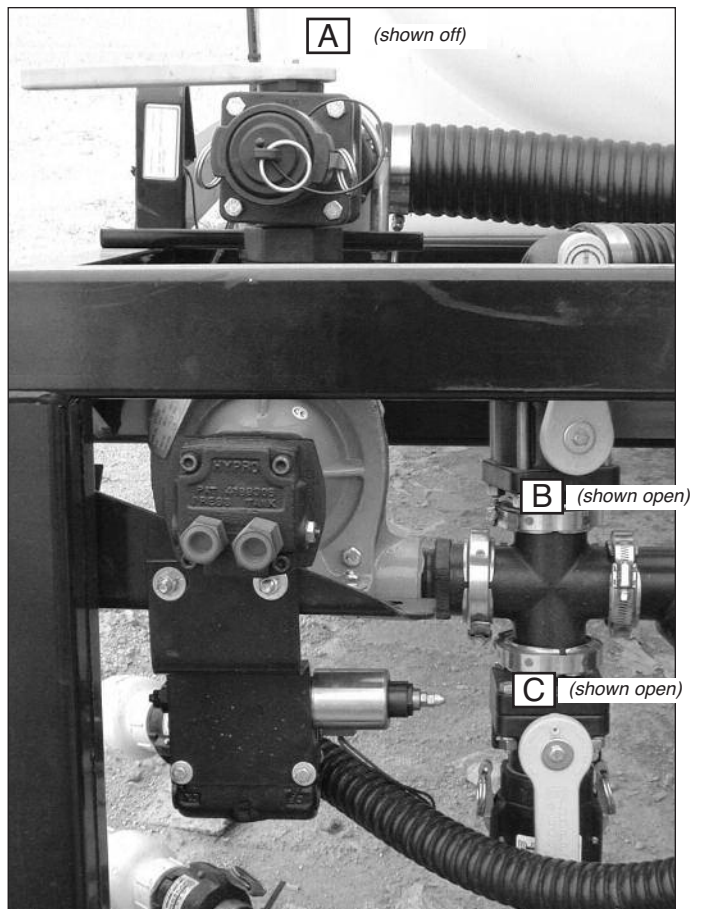

Bulk Fill Mode

MAINTENANCE INSTRUCTIONS

In Season:

- During periods of non-use it is recommended that the system be flushed of de-icing chemicals using antifreeze.

Example: CARGILL recommends the vehicle be steam-cleaned after each use and that the liquid system be flushed with hot water. After flushing, it is extremely important to rid the system of all water. If this is not done, the water will freeze and damage or destroy your components.

Other chemical companies may not want water used. Water used for flushing could turn the chemical into a jelly-like substance. Check with your chemical supplier for proper flush liquids. Inspect hose for cracks and replace as needed. If replacing a hose is required, refer to your supplier for proper product reference.

- Reapply dielectric grease regularly to pins and receivers on all wire harness connectors to prevent corrosion of these terminals.

****NOTICE:** *The wire harness used in this system utilizes epoxy-sealed or “potted” end connectors. Due to the severe environment in which these connections operate, modifications to these connectors and harnesses are strongly discouraged. Replacement harnesses are available from Monroe Truck Equipment Snow & Ice Parts Sales.*

Off Season: *(If Applicable)*

Getting the liquid system ready for summer storage will save you a great deal of time and money when fall comes for remounting.

- Fully flush the complete system. This will prevent high concentrations from forming and burning holes in your steel tanks, mild or stainless.
- Inspect the nozzles for residual caking of liquid material and clean them.

*When flushing the system, cycle each valve through its **full** range of operation to ensure that the entire body of the valve has been flushed.*

MAINTENANCE INSTRUCTIONS

BRAND HYDRAULIC VALVE MAINTENANCE (IF EQUIPPED)

Manual Override of the Solenoid

Should the valve refuse to respond to the electrical control, the mechanical function of the the valve can be checked by manually actuating the spool. To do this, remove the acorn nut and loosen the jam nut. Turn the stud clockwise until it reaches the stop. **DO NOT OVER TIGHTEN.** In this position, the electronic control of the valve is overridden and the valve will pass 100% of the flow to the motor.

****CAUTION**** When the valve is in this position, care must be taken to avoid over driving the motor and product pump. This procedure should be used as a troubleshooting tool and is not recommended as a mode of operation.

If the need to disassemble the valve arises, care must be taken when reassembling the valve so that the pin seats fully in the adjustment spool. This is most easily done by reassembling the valve in the vertical position so that gravity holds the pin in the proper orientation.

FILLING INSTRUCTIONS FOR THE RAVEN DCS 710

Self-Filling Procedure

- Set the DCS710 Raven Console in the manual position on Rate knob, as shown below.



- Connect ground based bulk tank suction hose to the camlock coupler by the self-fill/main tank outlet valve on the unit, (Valve “A”). Check chart and confirm that all other valves are in position for self fill.
- Set main power switch to the “GR/LI” position and the lane box switch to the “Anti” position. Set all boom switches to “Lane” position within the Lane Box to keep liquid from leaking and set Master Switch to “ON” position.
- Open the ground based tank valve.
- With the truck and hydraulics to the anti-ice unit running, toggle the manual increase/decrease switch (must hold for 4-5 seconds to activate system) increasing until the desired fill rate is reached. **CAUTION:** Too fast of pump speed may cause pump to cavitate depending upon size of nurse hose and fittings.
- The Hypro pump requires liquid in it to prime, if liquid in nurse tank is lower then the pump it may be necessary to lift the nurse hose approximately 8 ft. from truck to cause anti-ice solution to enter the pump.
- **CAUTION:** Operating pump without prime (dry) for a prolonged period of time will cause pump seal failure. If prime is difficult to establish, shut down pump between attempts to allow seal to cool.
- When desired level is reached in the anti-ice unit, close the ground based bulk tank valve and release quick coupler from valve. This will pull product from the hose. When the hose is empty, switch valve “A” from storage to tank, and shut down the system.
- Disconnect suction hose, close the fill/agitate valve “B”.

Emptying Procedure

- To empty system back into the ground based bulk tank, connect bulk hose (not provided) from tank, to the Unload valve, (valve “C”), on the unit, then open bulk tank valve. Position valves as shown in chart for Unload Mode.
- Set main power switch to the “GR/LI” position, the Lane box switch to the “Anti” position, and set the DCS710 console to the manual position as shown. Set all boom switches to “Lane” position within the Lane Box to keep liquid from leaking and set Master Switch to “ON” position.
- With the truck and hydraulics to the anti-ice unit running, toggle the manual switch, (must hold for 4-5 seconds to activate system) increasing until the desired fill rate is reached.
- When anti-ice unit tank is empty, shut down system, and close Unload valve, (valve “C”) on the unit.
- Disconnect bulk fill hose.

Agitation Procedure

- Position valves as shown in the chart for the Agitation Mode.
- Set main power switch to the “GR/LI” position, the Lane box switch to the “Anti” position, and set the DCS710 console to the manual position as shown. Set all boom switches to “Lane” position within the Lane Box to keep liquid from leaking and set Master Switch to “ON” position.
- With the truck and hydraulics to the anti-ice unit running, toggle the manual switch, (must hold for 4-5 seconds to activate system) increase until the desired flow rate is reached.
- When finished agitating product, shut down system and close the fill agitate valve, (valve “B”).

FILLING INSTRUCTIONS FOR THE RAVEN DLA336

Self-Filling Procedure

- Set the DLA336 Raven Console in the manual position on Rate knob, as shown below.



- Connect ground based bulk tank suction hose to the camlock coupler by the self-fill/main tank outlet valve on the unit, (Valve “A”). Check chart and confirm that all other valves are in position for self fill.
- Set main power switch to the “On” position. Set all boom switches to “Off” position to keep liquid from leaking and set Master Switch to “On” position.
- Open the ground based tank valve.
- With the truck and hydraulics to the anti-ice unit running, toggle the manual increase/decrease switch (must hold for 4-5 seconds to activate system) increasing until the desired fill rate is reached. **CAUTION:** Too fast of pump speed may cause pump to cavitate depending upon size of nurse hose and fittings.
- The Hypro pump requires liquid in it to prime, if liquid in nurse tank is lower then the pump it may be necessary to lift the nurse hose approximately 8 ft. from truck to cause anti-ice solution to enter the pump.
- CAUTION:** Operating pump without prime (dry) for a prolonged period of time will cause pump seal failure. If prime is difficult to establish, shut down pump between attempts to allow seal to cool.
- When desired level is reached in the anti-ice unit, close the ground based bulk tank valve and release quick coupler from valve. This will pull product from the hose. When the hose is empty, switch valve “A” from storage tank, and shut down the system.
- Disconnect suction hose, close the fill/agitate valve “B”.

Emptying Procedure

- To empty system back into the ground based bulk tank, connect bulk hose (not provided) from tank, to the Unload valve, (valve “C”), on the unit, then open bulk tank valve. Position valves as shown in chart for Unload Mode.
- Set the DLA336 Raven Console in the manual position on Rate knob, as shown above.
- Set the main power switch to the “On” position. Set all boom switches to “Off” position to keep liquid from leaking and set Master Switch to “On” position.
- With the truck and hydraulics to the anti-ice unit running, toggle the manual switch, (must hold for 4-5 seconds to activate system) increasing until the desired fill rate is reached.
- When anti-ice unit tank is empty, shut down system, and close Unload valve, (valve “C”) on the unit.
- Disconnect bulk fill hose.

Agitation Procedure

- Position valves as shown in the chart for the Agitation Mode.
- Set the DLA336 Raven Console in the manual position on Rate knob, as shown above.
- Set main power switch to the “On” Position. Set all boom switches to “Off” position to keep liquid from leaking and set Master switch to “On” position.
- With the truck and hydraulics to the anti-ice unit running, toggle the manual switch, (must hold for 4-5 seconds to activate system) increase until the desired flow rate is reached.
- When finished agitating product, shut down system and close the fill agitate valve, (valve “B”).

INSTALLATION INSTRUCTIONS

Loading Anti-Ice Unit Into Dump Body

1. Measure the inside width of the dump body and the distance from the tailgate latch pins to the front of the body. Verify that the anti-ice unit will fit inside the dump body. Verify that there are no obstructions in the dump body that the anti-ice unit will contact.
2. Remove the tailgate from the body. Leave the lower latch fingers open.
3. Secure hoses and harnesses on the anti-ice unit to prevent damage as the unit is loaded into the dump body.
4. Raise the dump body 12 inches at the front. This will allow the rollers at the front of the anti-ice unit to roll up the dump body floor.
5. Back the truck toward the anti-ice unit. Have an observer verify that the truck is centered on and square with the anti-ice unit.
6. As the rollers start moving up the dump body floor, the front legs of the anti-ice unit will raise off the ground. Stop the truck just before the dump body contacts the front legs.
7. Attach the safety chains to the lower keyhole plates on the dump body. Pull the chains as tight as possible to eliminate slack. If hooks are provided on the long members, the chains can be hung on these hooks to keep them from interfering with the rollers.



8. Remove the lock pins from the front legs. Swing the legs up and pin them to the unit long members.
9. Continue backing the truck under the anti-ice unit. The front leg braces should swing up out of the way as the dump body travels under the unit. If the chains were attached to the hooks on the long members, they should pull off the hooks as the unit progresses into the dump body.
10. When the latch pins on the anti-ice unit are 1-2 inches away from the latch saddles on the dump body, stop the truck.
11. Lower the dump body. This will raise the rear legs off the ground.
12. Remove the lock pins from the rear legs, raise the legs as high as possible, then reinstall the pins.
13. Drive the truck forward, accelerating slowly to about 10 mph. Apply the brakes sharply to make the anti-ice unit slide forward to the latch saddles on the dump body. Repeat if necessary to seat the latch pins in the saddles.
14. Latch the pins securely.
15. If turnbuckles or load binders are used at the front of the anti-ice unit, install these now.
16. Install a minimum of two load (ratchet) straps over the top of the anti-ice unit and secure them to the tie rails on the sides of the dump body.
17. Apply dielectric grease to all electrical connectors and connect them securely.
18. Clean all dirt off of hydraulic quick connectors and connect them securely.
19. Fill the liquid tank about 1/8 full, then test all functions of the anti-ice system.
20. When proper operation has been verified, the anti-ice system is ready for use.

INSTALLATION INSTRUCTIONS

Unloading Anti-Ice Unit From Dump Body

1. Verify that all liquid has been drained from the tank. Do not attempt to unload the unit with liquid in the tank.
2. Disconnect all hoses and harnesses and secure them to the anti-ice unit to prevent damage as the unit is unloaded from the dump body.
3. Remove the load (ratchet) straps from the across the unit.
4. Remove any turnbuckles or load binders from the front of the unit.
5. Remove the lock pins at the rear legs, lower the legs as close to the ground as possible, then reinstall the lock pins.
6. Verify that the safety chains are connected to the keyhole plates on the dump body.

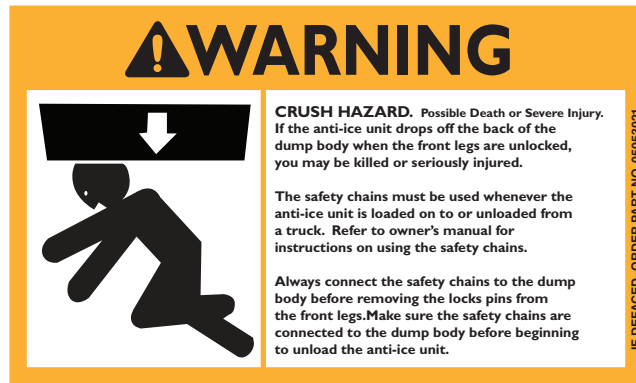

7. Release the tailgate latch.
8. Raise the dump body until the rear legs are in firm contact with the ground and the long members of the anti-ice unit are raised off the dump floor. At this point only the front rollers should be in contact with the dump body floor.
9. Drive the truck forward very slowly until the pins holding the front legs up can be removed.
10. Continue driving forward slowly until the front legs and the braces drop down.
11. Install the safety pins at the front legs to hold them in place.
12. Disconnect the safety chains and hang them on the hooks on the long members.
13. Drive forward slowly until the anti-ice unit is clear of the dump body.

INSTALLATION INSTRUCTIONS

Liquid De-Icer Hydraulic Connections

The Anti-Icing Unit needs the hydraulic pressure and return lines connected to the liquid de-icer pump.

1. Install a mating auger/conveyor (pressure) quick disconnect coupler, *customer supplied*, to the end of the pressure line going to the liquid de-icer pump.
2. Install a mating spreader (return) quick disconnect coupler, *customer supplied*, to the end of the return line coming from the liquid de-icer pump.

Note: If the liquid de-icer pump is not producing enough fluid, attach a short length of ½" 100R2 hose, *customer supplied*, to the plugged port of the tee installed by the auger/ conveyor quick disconnect coupler and the other end to a mating spinner quick disconnect coupler, *customer supplied*. Spinner line may have to be T'd to conveyor or return to eliminate back pressure.

3. Connect the couplers to the respective connection on the truck.

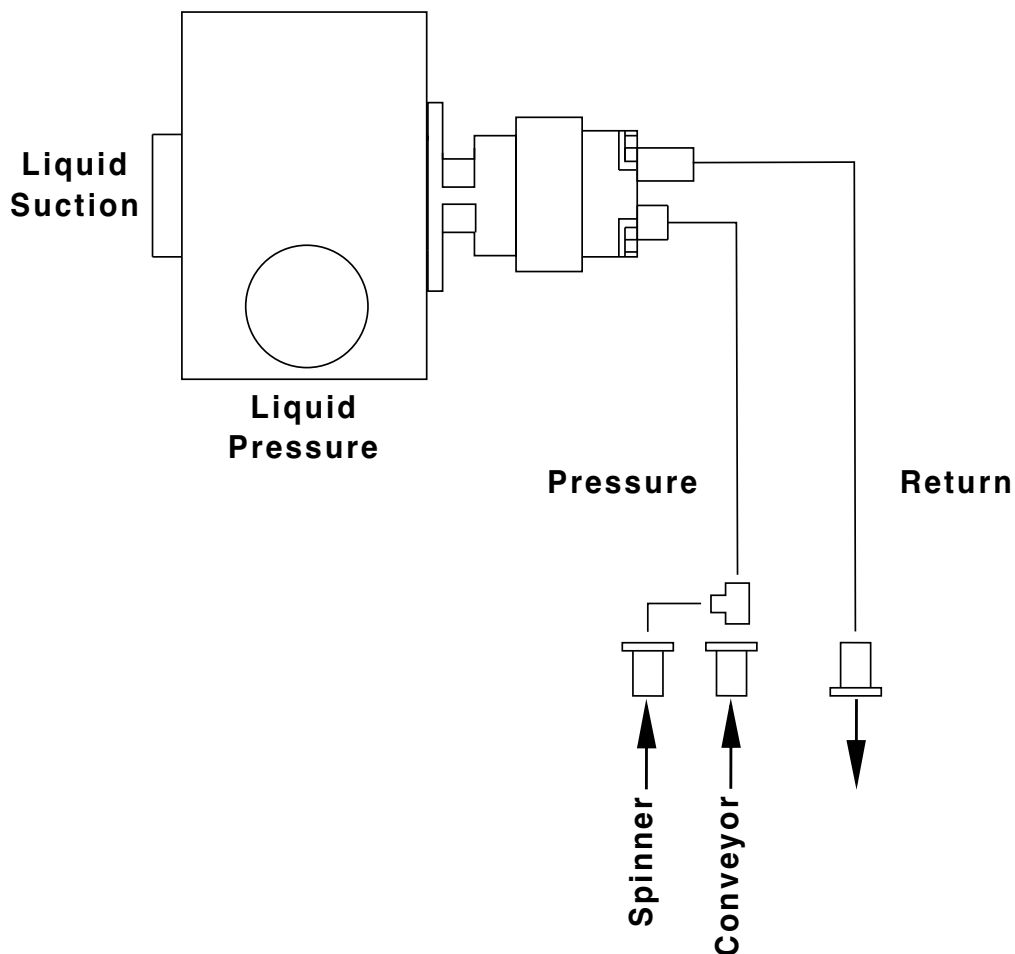

INSTALLATION INSTRUCTIONS

Ground Speed Optional Plumbing

1. Remove the current pressure hose going to the liquid de-icer hydraulic motor.
2. Reconnect the just removed pressure hose and attach it to the inlet of the PWM proportional control valve.
3. Install a new length of $\frac{1}{2}$ " 100R2 hose, *customer supplied*, from the controlled flow port to the pressure port of the liquid de-icer hydraulic motor.
4. Look at the below illustrations to finish the plumbing based on what type of hydraulic system you have.

Note: If you have a load sensing hydraulic system you will require an additional $\frac{3}{8}$ " quick coupler, $\frac{1}{2}$ " high pressure tee and a length of $\frac{3}{8}$ " 100R2 hose for the load sensing line.

For Load Sensing Systems

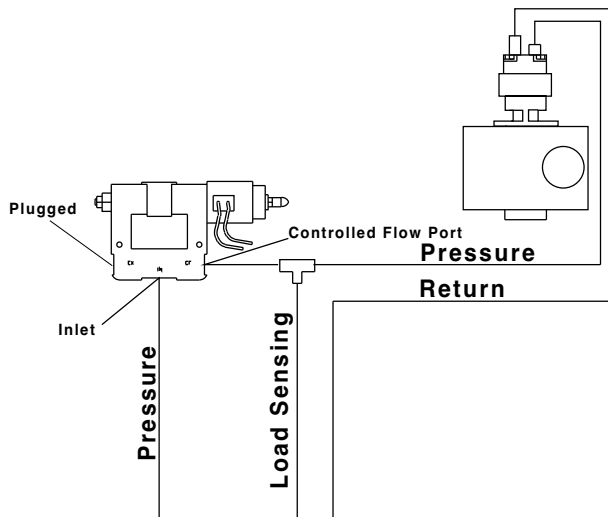

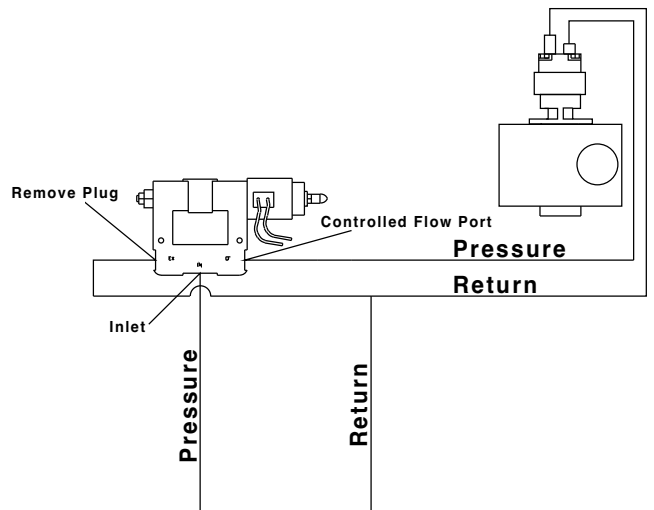

For Gear Pump Systems



GENERAL INFORMATION

- Location descriptions are noted in direction of travel. (i.e. front, rear, left and right.)
- Delivery of replacement parts is subject to our sales delivery terms.
- Use only **Monroe Truck Equipment** O.E.M. replacement parts. Failure to do so will void warranty.
- Replacement parts listed in this manual reflect our most common items. If you do not find the part you require, please call your distributor.
- **Monroe Truck Equipment** reserves the right to make revisions or alterations to this parts manual.

TORQUE CHART

SIZE	 GRADE 2	 GRADE 5	 GRADE 8
1/4-20	50 IN-LBS	75 IN-LBS	9 FT-LBS
3/8-16	15 FT-LBS	23 FT-LBS	35 FT-LBS
1/2-13	35 FT-LBS	55 FT-LBS	80 FT-LBS
5/8-11	75 FT-LBS	110 FT-LBS	170 FT-LBS
3/4-10	130 FT-LBS	200 FT-LBS	280 FT-LBS
1-8	190 FT-LBS	480 FT-LBS	680 FT-LBS
1 1/4-7	380 FT-LBS	840 FT-LBS	1360 FT-LBS

NOTES

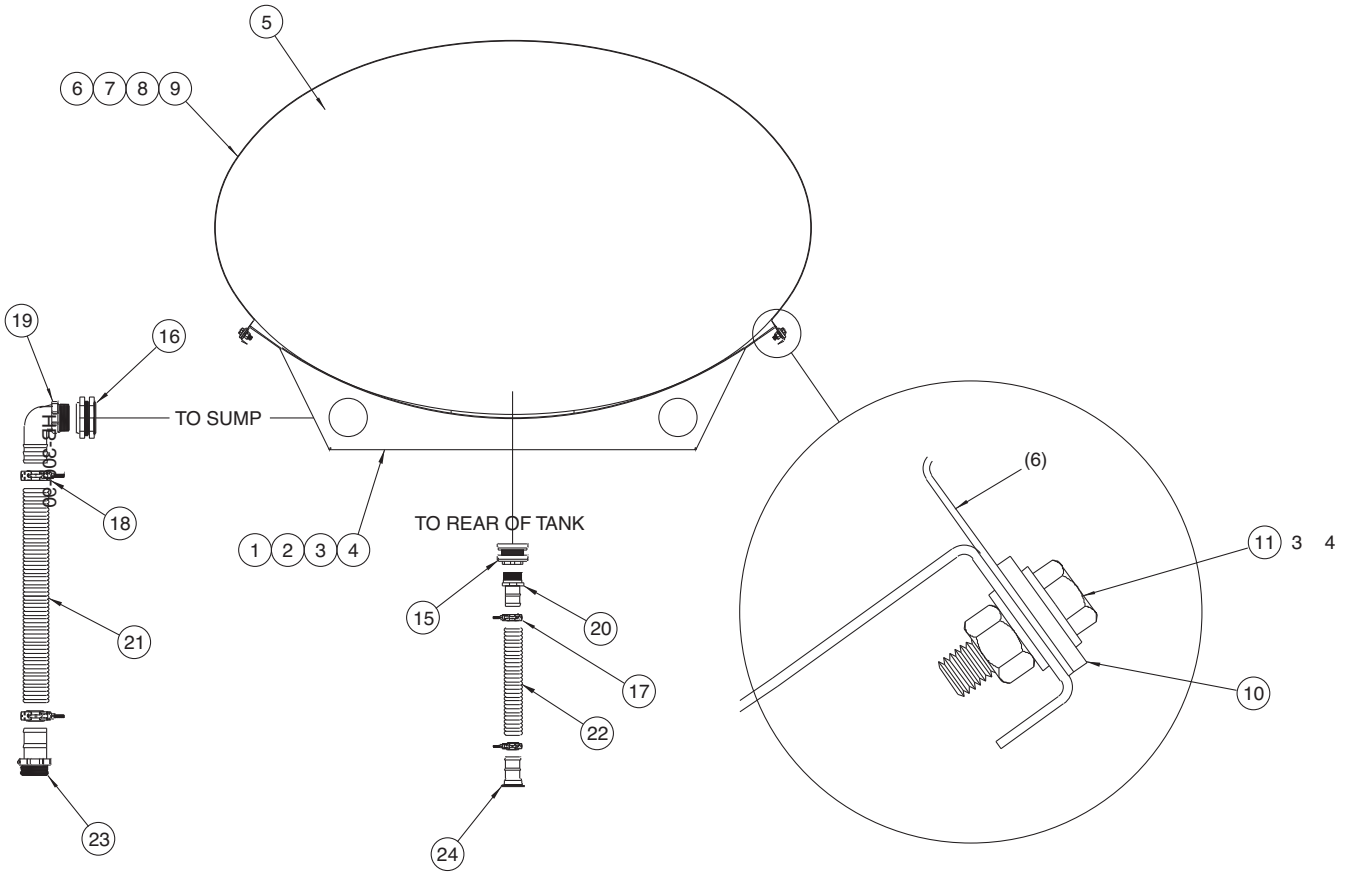

00048827 TANK KIT, 1000 GALLON

Item	Qty	Part Number	Description
1	1	00044179-A	Saddle Weldment, MS
	1	00044179-B	Saddle Weldment, SST
2	12	05010690	Bolt, ½-13 x 1½, G8, HHCS, Zinc
	12	05016045	Bolt, ½-13 x 1½, HHCS, SST
3	36	05021005	Washer, ½, Flat, Mil-Carb
	36	05021391	Washer, ½, Flat, SST
4	18	05020847	Nut, ½-13, GC, Top Lock, C&W
	18	05020908	Nut, ½-13, Nylon Lock, 316 SST
5	1	05050550	Tank, 1000 Gallon, Elliptical
6	6	00042615	Band Half, Adj, Tank Hold Down
7	12	05015064	Bolt, ⅝-18 x ⅝, BSCS, SST
8	12	05021404	Washer, ⅝, Flat, SST
9	12	05020907	Nut, ⅝-18, Nylon Lock, SST
10	12	00049124-B	Tab, Reinforcement Tank Band, SST
11	6	05016931	Bolt, ½-13 x 3, G5, HH, Tap, Bolt
	6	05016959	Bolt, ½-13 x 3, HHCS, SST
12	6	05050686	Cable Tie, HD
13	1	05050699	Decal, Warning
14	4.5 FT	05050791	Trim, Channel, Black
15	1	05037550	Fiting, Bulkhead, Poly, 2"
16	1	05038411	Fitting, Bulkhead, Poly, 3"
17	2	05050615	Clamp, 2" T-Bolt, SS
18	2	05050461	Clamp, 3" T-Bolt, SS
19	1	05037639	Hose Barb, 3" x 3" MNPT, Poly, 90°
20	1	05037386	Hose Barb, 2" x 2" MNPT, Poly, Straight
21	7 FT	05037623	Hose, 3" ID, Black Ribbed, EPDM
22	4 FT	05037577	Hose, 2" ID, Black Ribbed, EPDM
23	1	05037469	Hose Barb, 3" x 3" MNPT, Poly, Straight
24	1	05037754	Hose Barb, Manifold, 2" x 2" Flange, Poly
25	1	05052045	Decal, Warning Monroe Snow & Ice Control

(20)

00094168 TANK KIT, ANTI-ICE-1300GALLON, LEG, 1TK, W/2" RETURN

Item	Qty	Part Number	Description
1	1	05052560	TANK, 1300 GALLON, ROUND POLY, WHITE, LEG STYLE
2	1	05052561	HOOK FOR 1300 GALLON TANK, SET OF 3
3	6	00042662-A 00042662-B	MOUNT, HOOP, 1850/925 GALLON TANK, MS MOUNT, HOOP, 1850/925 GALLON TANK, SST
4	12	05016931 05016959	BOLT, .5-13 X 3, G5, HH TAP ZINC BOLT, .5-13 X 3, HHCS, SST
5	48	05021005 05021391	WASHER, .5, FLAT, MIL-CARB, STD WASHER, .5, FLAT, SST
6	24	05020847 05020908	NUT, .5-13, GC, TOP LOCK, C&W NUT, .5-13, NYLOCK, SST
7	1	05050699	DECAL, WARNING, FOLLOW CONFINED SPACE
8	6	05014092 05016854	BOLT, .625-11 X 1.5, G5, CARRIAGE, ZINC BOLT, .625-11 X 1.5, CARRAIGE, SST
9	6	05021017 05021406	WASHER, .625, FLAT, MIL-CARB, SAE WASHER, .625, FLAT, SST, 18-8, .687" ID X 1.5"OD
10	6	05020837	NUT, .625-11, GC, TOP LOCK C&W
11	12	05010691 05016096	BOLT, .5-13 X 1.5, G8, HHCS, ZINC BOLT, .5-13 X 1.5, HHCS, SST
12	6	00069586-A 00069586-B	BRACKET WELDMENT, SUPPORT, TANK, 925/1800 GAL BRACKET, WELDMENT, SUPPORT, TANK, 925/1800 GAL, SST
13	3	00069589-A 00069589-B	REINFORCEMENT, CROSSMEMBER, TANK SUPPORT REINFORCEMENT, CROSSMEMBER, TANK SUPPORT, SST
14	2	05050615	CLAMP, 2" T-BOLT, SS, 2.62" MAX, DIA
15	2	05050461	CLAMP, 3" T-BOLT, FOR CF300 HOSE, SST
16	1	05037469	HOSE BARB, 3" X 3" MNPT, POLY, STRAIGHT
17	1	05037386	HOSE BARB, 2" X 2" MNPT, POLY, STRAIGHT
18	10 FT	05037623	HOSE, 3" ID, BLACK RIBBED, EPDM, POLY
19	10 FT	05037577	HOSE, 2" ID, BLACK RIBBED, EPDM, POLY
20	1	05037754	HOSE BARB, MANIFOLD, 2" X 2" FLANGE, POLY, STRAIGHT
21	1	05038411	FITTING, BULKHEAD, POLY, 3" FNPT, SINGLE
22	4	05052475	CLAMP, .375" CUSHIONED METAL, #6, .5" WIDE, SST
23	4	05016942	SCREW, #10-16 X .75 HEX W/ HEAD TEK SC
24	5	05010617 05016137	BOLT, .313-18 X .875, G8, HHCS, ZINC BOLT, .313-18 X .875, HHCS, SST
25	5	05020909 05020907	NUT, .313-18, GC, TOP LOCK, C&W NUT, .313-18, NYLON LOCK, 316 SST
26	5	25740	CLAMPS, LOOM CLAMP, #40 HEAVY DUTY
27	1	05052045	DECAL, WARNING, MONROE SNOW & ICE CONTROL
28	1	05037639	FITTING, BARB, 3 X 3" MNPT, POLY, 90°

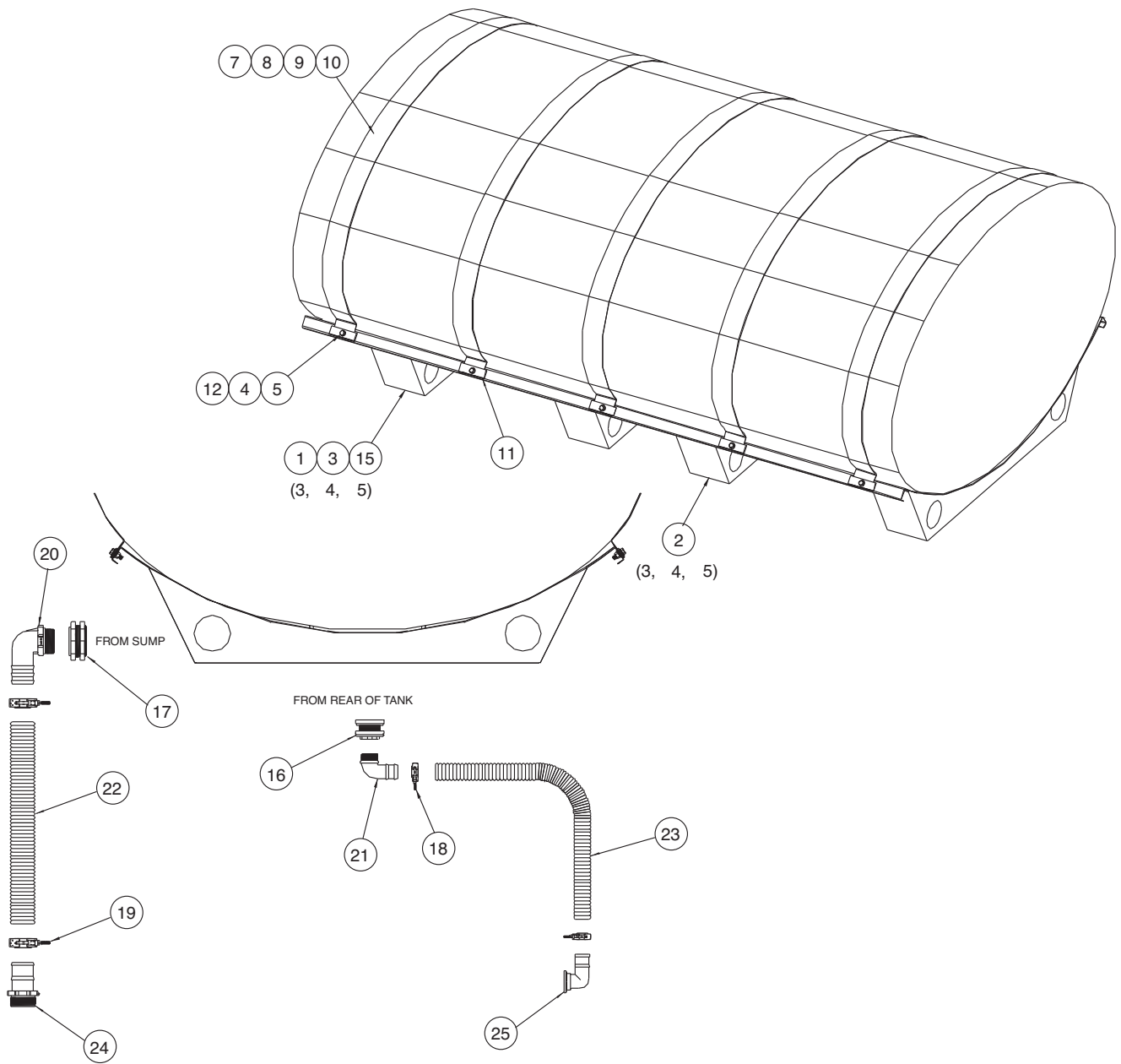

00048829 TANK KIT, 1600 GALLON

Item	Qty	Part Number	Description
1	1	00045032-A	Saddle Weldment, Rear, Half, MS
	1	00045032-B	Saddle Weldment, Rear, Half, SST
2	1	00045039-A	Saddle Weldment, Front, Half, MS
	1	00045039-B	Saddle Weldment, Front, Half, SST
3	16	05010690	Bolt, ½-13 x 1½, G8, HHCS, Zinc
	16	05016803	Bolt, ½-13 x 1½, Carriage, SST
4	52	05021005	Washer, ½, Flat, Mil-Carb, Std
	52	05021391	Washer, ½, Flat, SST
5	26	05020847	Nut, ½-13, GC, Top Lock, C&W
	26	05020908	Nut, ½-13, Nylon Lock, SST
6	1	05050513	Tank, 1600 Gallon Elliptical
7	10	00042615	Band Half, Adju Tank Hold Down
8	20	05015064	Bolt, ⅝-18 x ⅝, BSCS, SST
9	20	05021404	Washer, ⅝, Flat, SST
10	20	05020907	Nut, ⅝-18, Nylon Lock, SST
11	20	00049124-B	Tab Reinforcement Tank Band, SST
12	10	05016931	Bolt, ½-13 x 3, G5, HH Tap, Bolt
13	10	05050686	Cable Tie
14	1	05050699	Decal, Warning, Follow Confined Space
15	5 FT	05050791	Trim, Channel, Black (Sump Area)
16	1	05037550	Fitting, Bulkhead, Poly 2"
17	1	05038411	Fitting, Bulkhead, Poly 3"
18	2	05050615	Clamp, 2" T-Bolt, SS
19	2	05050461	Clamp, 3" T-Bolt
20	1	05037639	Hose Barb, 3" x 3" MNPT, Poly, 90°
21	1	05037387	Hose Barb, 2" x 2" MNPT, Poly, 90°
22	8 FT	05037623	Hose, 3" ID, Black, Ribbed, EPDM
23	8 FT	05037577	Hose, 2" ID, Black Ribbed, EPDM
24	1	05037469	Hose Barb, 3" x 3" MNPT, Poly, Straight
25	1	05037892	Hose Barb, Manifold, 2" x 2" Flange, Poly, 90°
26	1	05052045	Decal, Warning

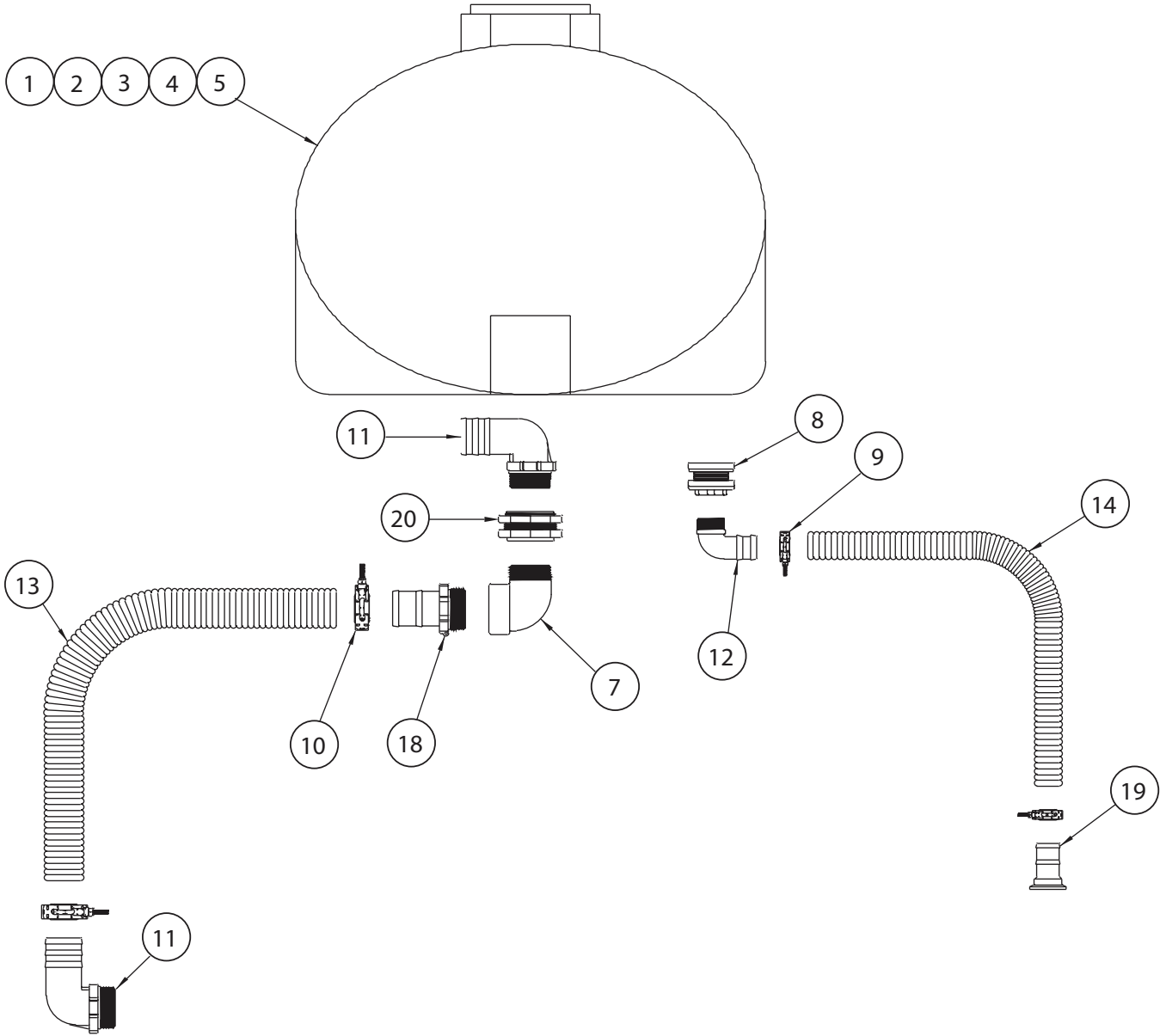

00048830 TANK KIT, 1635 GALLON

Item	Qty	Part Number	Description
1	1	05050430	Tank, 1635 Gallon, Elliptical Baffled
2	4	05050433	Hoop for 1635 Gallon Tank
3	8	05016931	Bolt, ½-13 x 3, G5, HH Tap Bolt
	8	05016959	Bolt, ½-13 x 3, SST
4	16	05021005	Washer, ½, Flat, Mil-Carb, Std
	16	05021391	Washer, ½, Flat, SST
5	8	05020847	Nut, ½-13, GC, Top Lock, C&W
	8	05020908	Nut, ½-13, Nylon Lock, SST
6	1	05050699	Decal, Warning, Follow Confined Space
7	1	05038069	Fitting, Nipple, Manifold, 3 Flange x 3" MNPT, Poly
8	1	05037550	Fiting, Bulkhead, Poly, 2"
10	2	05050615	Clamp, 2" T-Bolt, SS
11	2	05050461	Clamp, 3" T-Bolt
12	1	05037639	Hose Barb, 3" x3" MNPT, Poly, 90°
13	1	05037387	Hose Barb, 2" x 2" MNPT, Poly
14	6 FT	05037623	Hose, 3" ID, Black Ribbed, EDPM, Poly
15	7 FT	05037577	Hose, 2" ID, Black, Ribbed, EPDM, Poly
16	1	00080731-A	Extension Kit, Skid Assembly
	1	00080731-B	Extension Kit, Skid Assembly
17	1	05052045	Decal Warning Monroe Snow & Ice Control
18	4	05038147	Fitting, Barb, Manifold, 3 x 3 Flange, Poly, 90°
19	1	05037469	Hose Barb, 3" x 3" MNPT, Poly, Straight
20	1	05037754	Hose Barb, 2" x 2" Flange, Poly, Striaght
21	1	05038074	Gasket, Flange, 3", EPDM, F/3" Manifold Valve
22	1	05038075	Gasket, Flange, 3", Viton, F/3" Manifold Valve

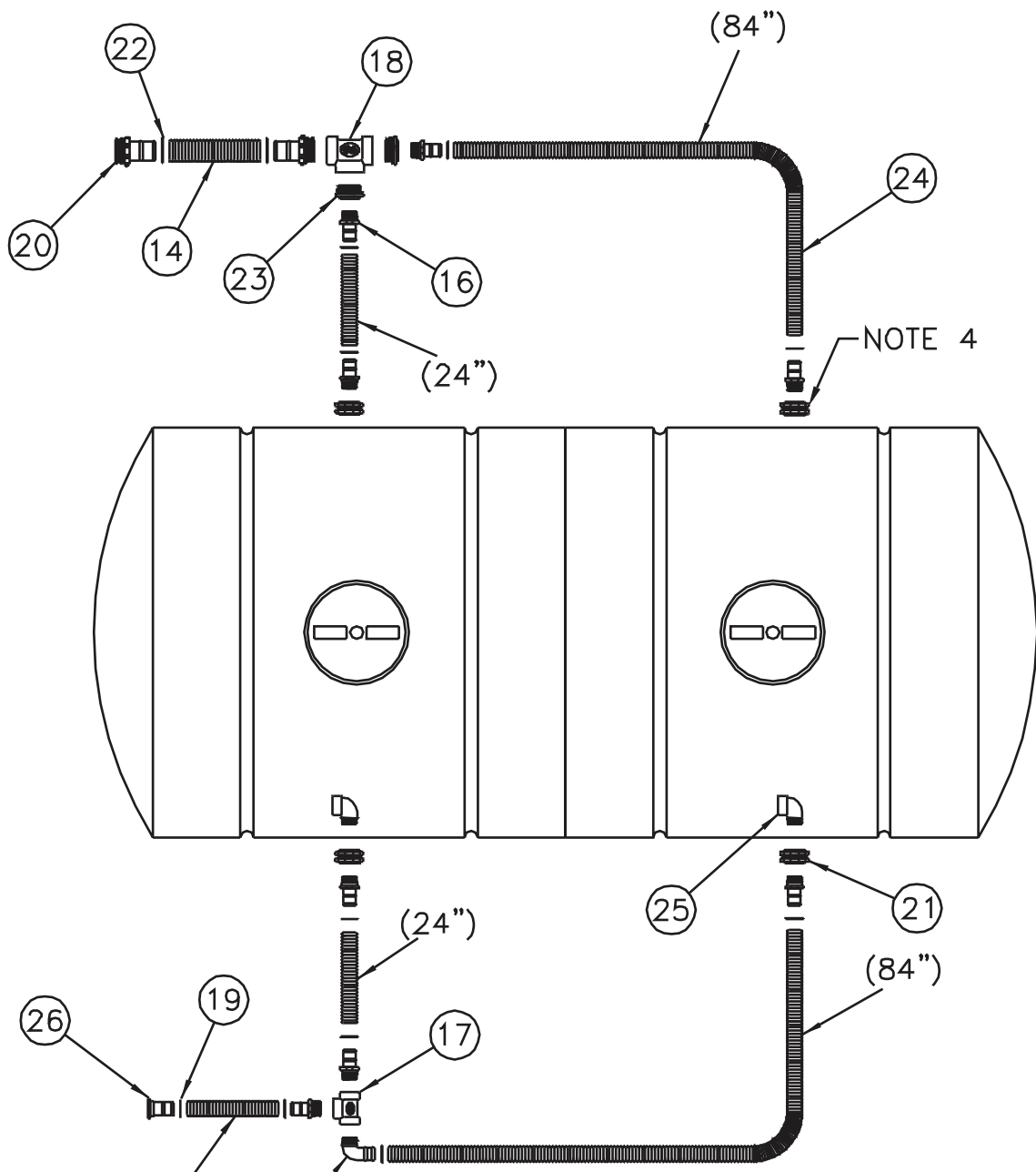

00047914 TANK KIT, 1800 GALLON

Item	Qty	Part Number	Description
1	1	05050325	Tank, 1800 Gallon, White, Poly
2	1	05050993	Hoop for 1800 Gallon Tank
3	8	00042662-A	Mount, Hoop, 1800 Gallon Tank, MS
	8	00042662-B	Mount, Hoop, 1800 Gallon Tank, SST
	8	00042662-D	Mount, Hoop, 1800 Gallon Tank, Ausst
4	16	05016931	Bolt, ½-13 x 3, G5, HH Tap Zinc
	16	05016959	Bolt, ½-13 x 3, SST
5	64	05021005	Washer, ½, Flat, Mil-Carb, Std
	64	05021391	Washer, ½, Flat, SST
6	32	05020847	Nut, ½-13, GC, Top Lock, C&W
	32	05020908	Nut, ½-13, Nylon Lock, SST
7	1	05050699	Decal, Warning, Follow Confined Space
8	16	05010691	Bolt, ½-13 x 1½, G8, HHCS, Zinc
	16	05016096	Bolt, ½-13 x 1½, HHCS, SST
9	8	00069586-A	Bracket Weldment, Support, MS
	8	00069586-B	Bracket Weldment, Support, SST
	8	00069586-C	Bracket Weldment, Support, Ausst
10	4	00069589-A	Reinforcement Cross member Tank Support, MS
	4	00069589-B	Reinforcement Cross member Tank Support, SST
	4	00069589-C	Reinforcement Cross Member Tank Support, AUSST
11	8	05014092	Bolt, ⅝-11 x 1½, G5, Carriage, Zinc
	8	05016854	Bolt, ⅝-11 x 1½, Carriage, SST
12	8	05021017	Washer, ⅝, Flat, Mil-Carb, SAE
	8	05021406	Washer, ⅝, Flat, SST
13	8	05020837	Nut, ⅝-11, GC, Top Lock, C&W
	8	05020903	Nut, ⅝-11, Nylon Lock, SST
14	3 FT	05037623	Hose, 3" ID, Black Ribbed
15	1	05037387	Hose Barb, 2" x 2" MNPT, Poly, 90°
16	8	05037386	Hose Barb, 2" x 2" MNPT, Poly, Straight
17	1	05037392	Tee, 2" Female NPT All Ports
18	1	05037477	Tee, 3" Poly
19	10	05050615	Clamp, 2" T-Bolt, SS
20	2	05037469	Hose Barb, 3" x 3" MNPT, Poly Straight
21	2	05037550	Fitting, Bulkhead, Poly
22	2	05050461	Clamp, 3" T-Bolt
23	2	05037445	Bushing Reducer
24	26 FT	05037577	Hose, 2' ID, Black Ribbed
25	2	05037443	Elbow, 2" NPT, Poly
26	1	05037754	Barb, Manifold, 2" Flange x 2" Hose Barb, Poly
27	4	05052475	Clamp, ⅝" ID, Cushioned Metal
28	4	05016942	Screw, #10-16 x ¼ Hex w/ Head Tek Screw, SST
29	5	25740	Clamps, Loom
30	5	05010617	Bolt, ⅝-18 x ⅞, G8, HHCS, Zinc
	5	05016137	Bolt, ⅝-18 x ⅞, HHCS, SST
31	5	05020909	Nut, ⅝-18, GC, Top Lock, C&W
	5	05020907	Nut, ⅝-18, Nylon Lock, SST

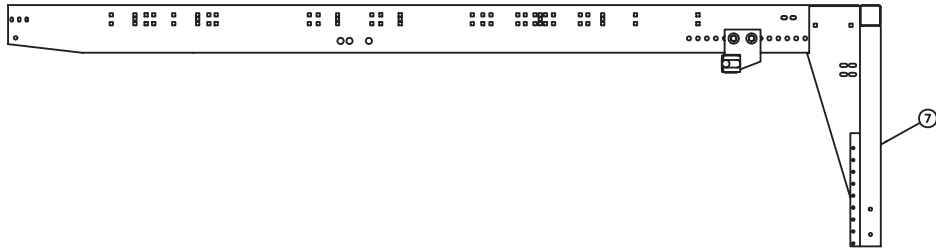
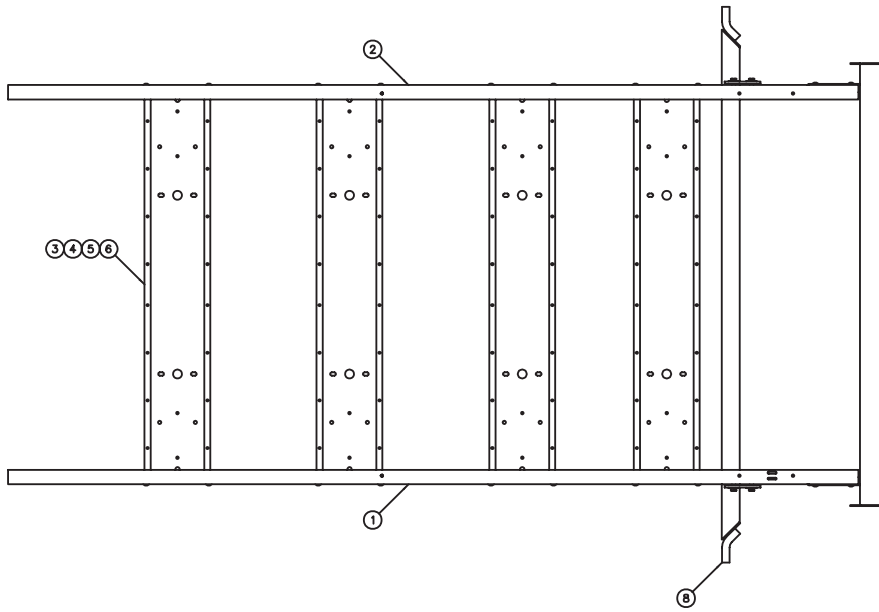

USE HOLES CONTAINED IN BOXES TO MOUNT CROSS BRACES FOR A 925 GAL TANK (05050721)



USE HOLES CONTAINED IN BOXES TO MOUNT CROSS BRACES FOR A 1000 GAL TANK SADDLE (00044179)

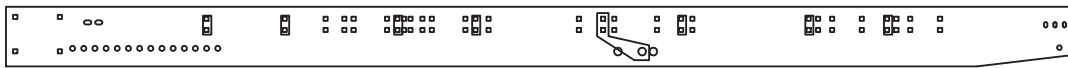

USE HOLES CONTAINED IN BOXES TO MOUNT CROSS BRACES FOR A 1035 GAL TANK (05052251)



USE HOLES CONTAINED IN BOXES TO MOUNT CROSS BRACES FOR A 1235 GAL TANK (05050355)



USE HOLES CONTAINED IN BOXES TO MOUNT CROSS BRACES FOR A 1300 GAL TANK (05052560)

00087016 SKID ASSEMBLY, NARROW

Item	Qty	Part Number	Description
1	1	00080720-A	Rail, Side, RH, Tank Skid, Narrow, MS
		00080720-B	Rail, Side, RH, Tank Skid, Narrow, SST
		00080720-C	Rail, Side, RH, Tank Skid, Narrow, AUSST
2	1	00080724-A	Rail, Side, LH, Tank Skid, Narrow, MS
		00080724-B	Rail, Side, LH, Tank Skid, Narrow, SST
		00080724-C	Rail, Side, LH, Tank Skid, Narrow, AUSST
	1	00080724-B	Rail, Side, LH, Tank Skid, Narrow, SST
3	4	00085173-A	Cross Channel Weldment, Combo, MS
		00085173-B	Cross Channel Weldment, Combo, SST
		00085173-C	Cross Channel Weldment, Combo, AUSST
	4	00085173-B	Cross Channel Weldment, Combo, SST
4	40	05014042	Bolt, .5-13 x 1.5, G5, Carriage, Zinc
	40	05016803	Bolt, .5-13 x 1.5, Carriage, SST
5	40	05021005	Washer, .5, Flat, Mil-Carb
	40	05020908	Washer,.5, Flat, SST
6	40	05020847	Nut, .5-13, GC, Top Lock, C&W
	40	05020908	Nut, .5-13, Nylon Lock, SST
7	1	00083794-A	Leg Weldment, Rear, Bolt-Together, MS
		00083794-B	Leg Weldment, Rear, Bolt-Together, SST
		00083794-C	Leg Weldment, Rear, Bolt-Together, AUSST
	1	00083794-B	Leg Weldment, Rear, Bolt-Together, SST
8	1	00082661-A	Latch Kit, TGT, MS <i>(See Below)</i>
	1	00082661-B	Latch Kit, TGT, SST <i>(See Below)</i>

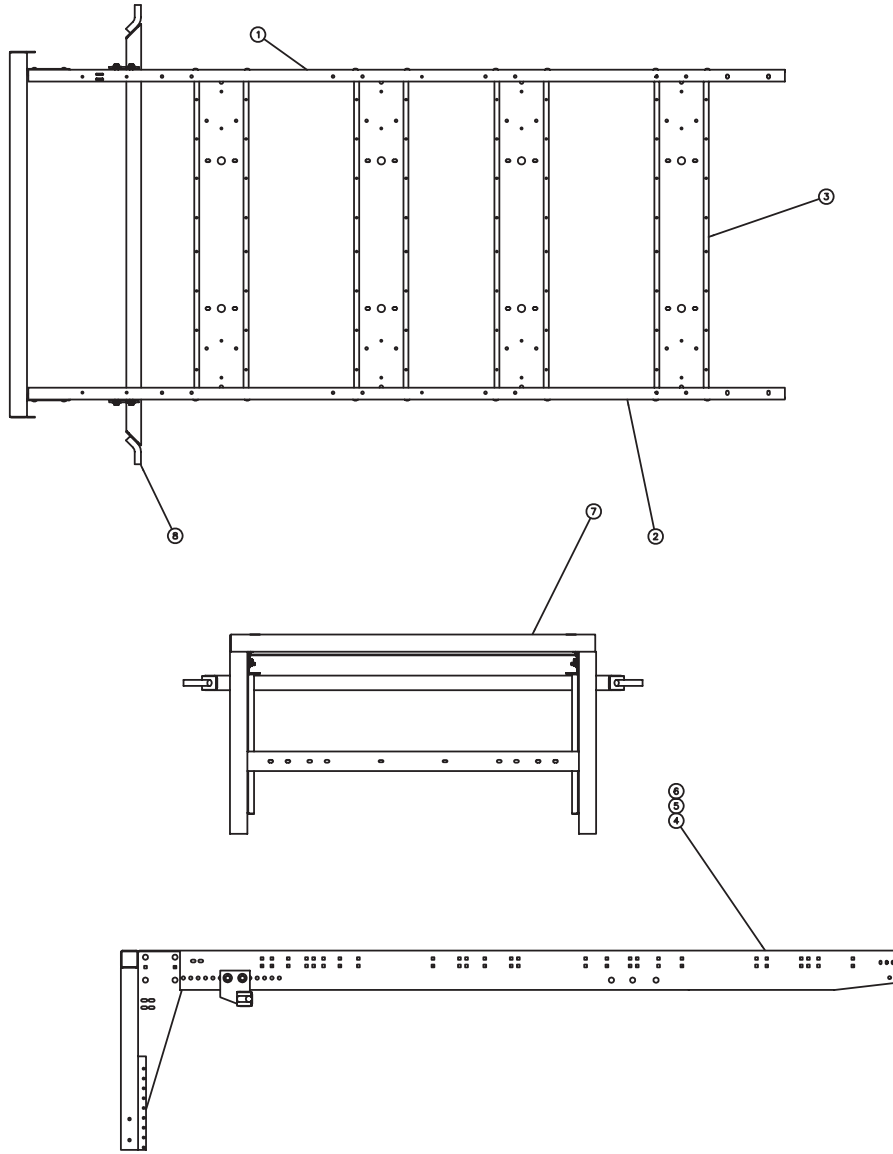

USE HOLES CONTAINED IN BOXES TO MOUNT CROSS BRACES FOR A 1600 GAL TANK (00048829)

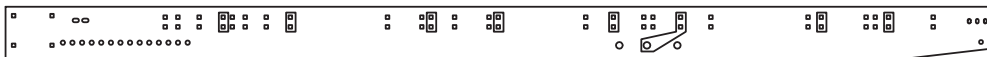

USE HOLES CONTAINED IN BOXES TO MOUNT CROSS BRACES FOR A 1635 GAL TANK (05050430)

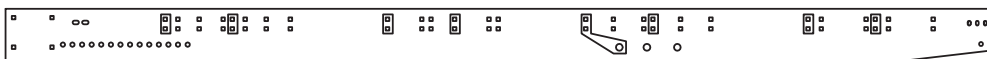

USE HOLES CONTAINED IN BOXES TO MOUNT CROSS BRACES FOR A 1800 GAL TANK (05050325)

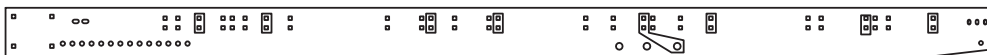

USE HOLES CONTAINED IN BOXES TO MOUNT CROSS BRACES FOR A 1750 GAL TANK (05052974)

00087431 SKID ASSEMBLY, NARROW, THRU-PIN

Item	Qty	Part Number	Description
1	1	00087429-A	Rail, Side, LH, Tank Skid, Narrow, MS
	1	00087429-B	Rail, Side, LH, Tank Skid, Narrow, SST
	1	00087429-C	Rail Side, LH Tank Skid, Narrow, Ausst
2	1	00087430-A	Rail, Side, RH, Tank Skid, Narrow, MS
	1	00087430-B	Rail, Side, RH, Tank Skid, Narrow, SST
	1	00087430-C	Rail, Side, RH, Tank Skid, Narrow, Ausst
3	4	00085173-A	Cross Channel Weldment, Combo, MS
	4	00085173-B	Cross Channel Weldment, Combo, SST
	4	00085173-C	Cross Channel Weldment, Combo, Ausst
4	40	05014042	Bolt, ½-13 x 1½, G5, Carriage, Zinc
	40	05016804	Bolt, ½-13 x 1.75, Carriage, SST
5	40	05021005	Washer, ½, Flat, Mil-Carb
	40	05021391	Washer, ½, Flat, SST
6	40	05020847	Nut, ½-13, GC, Top Lock, C&W
	40	05020908	Nut, ½-13, Nylon Lock, SST
7	1	00083794-A	Leg Weldment, Rear, Bolt-Together, MS
	1	00083794-B	Leg Weldment, Rear, Bolt-Together, SST
	1	00083794-C	Leg Weldment, Rear, Bolt-Together, Ausst
8	1	00082661-A	Latch Kit, TGT, MS <i>(See Below)</i>
	1	00082661-B	Latch Kit, TGT, SST <i>(See Below)</i>
	1	00082661-D	Latch Kit, TGT, AUSST

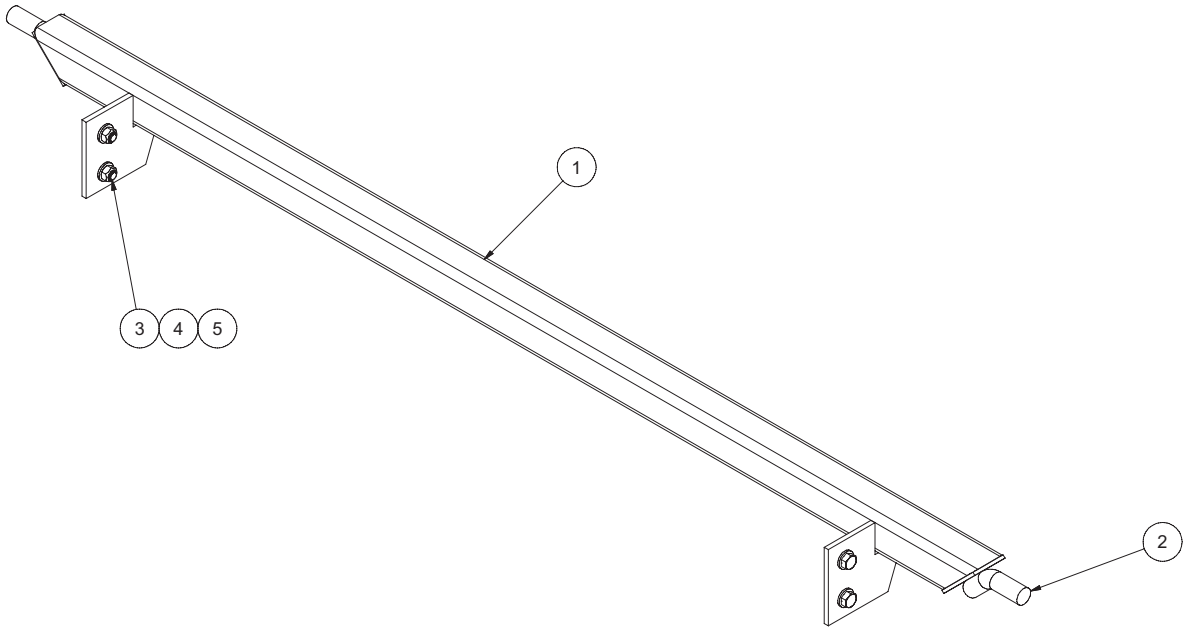

00082661 LATCH KIT

Item	Qty	Part Number	Description
1	1	00071342-A 00071342-B 00071342-C	Latch Weldment, Skid, MS Latch Weldment, Skid, SST Latch Weldment, Skid, AUSST
2	2	00028395-A 00028395-B 00028395-C	Pin, Tailgate Latch, HRR Pin, Tailgate Latch, HRR, SSR Pin, Tailgate Latch, HRR, NO PNT
3	4	05010737	Bolt, .625-11 x 1.5, G8, HHCS, Zinc
	4	05016248	Bolt, .625-11 x 1.5, HHCS, SST
4	4	05020837	Nut, .625-11, GC, Top Lock, C&W
	4	05020903	Nut, .625-11, Nylon Lock, SST
5	8	05021017	Washer, .625, Mil-Carb, Standard
	8	05021406	Washer, .625, Flat, SST

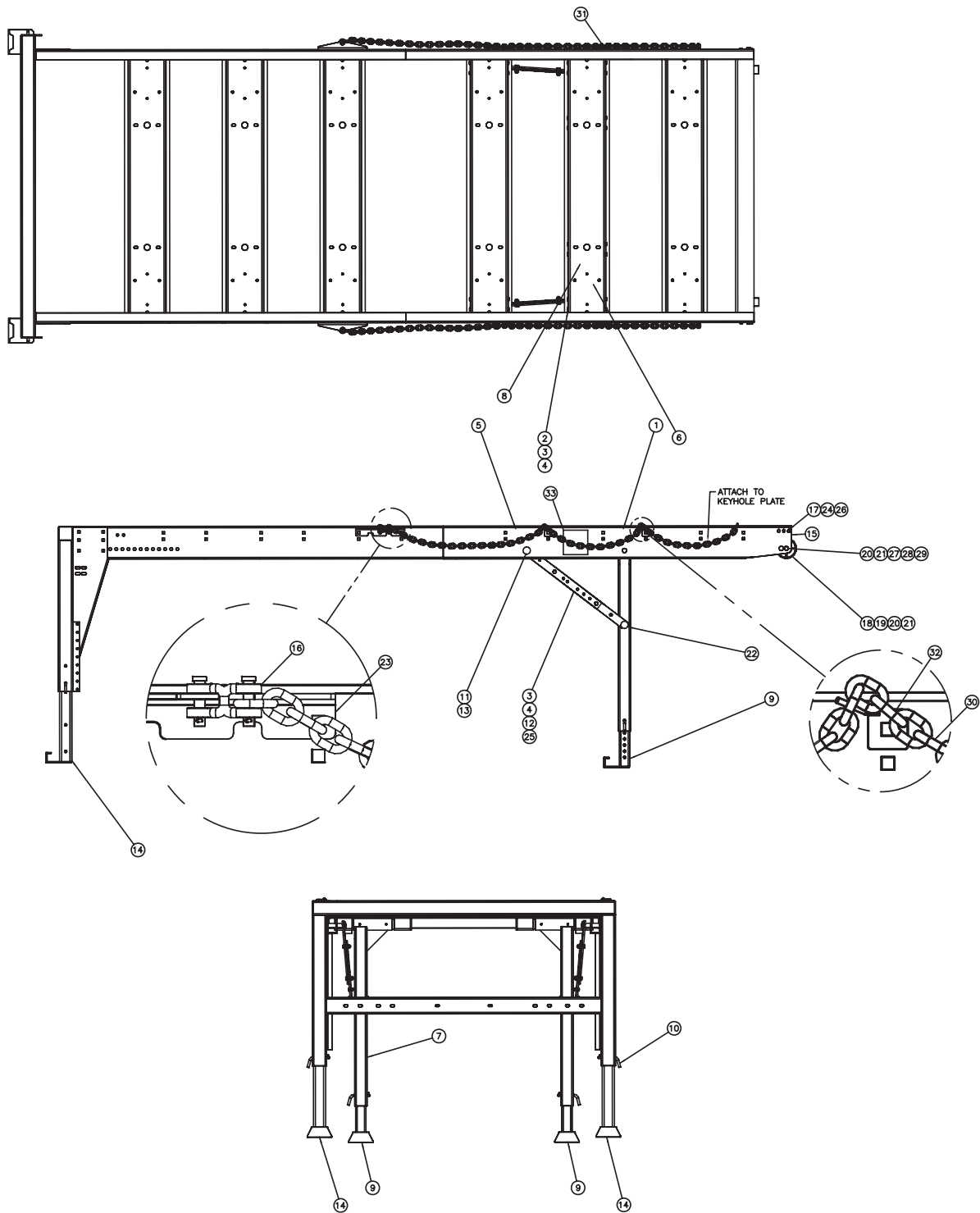

00083799-A LEG KIT

Item	Qty	Part Number	Description
1	4	00071356-A	MOUNT WELDMENT, FRONT, BOLT-ON, MS
2	24	05010690	BOLT, ½-13 X 1¼, G8, HHCS, ZINC
3	28	05021309	WASHER, ½, FLAT, ZINC
4	28	05020847	NUT, ½-13, GC, TOP LOCK, C&W
5	2	00056190-C	MOUNT, LEG, RAIL, BOLT-ON, MS
6	2	00071361	PIPE, 2 SCHED 40 X 18
7	2	00085111-A	LEG WELDMENT, FRONT, OUTER, MS
8	4	05050003	GREASE ZERK, ⅛ NPT, STRAIGHT
9	2	00083798-A	LEG WELDMENT, INNER, FRONT, MS
10	4	05022136	PIN, ½ X 4½, 4" GRIP BENT, MS
11	4	05022077	PIN, 1 X 4½, BUTTON HEAD, ZINC
12	4	00082646-A	BRACE PLATE, LEG, FRONT, MS
13	4	05022106	PIN, .188 LYNCH
14	2	00085104-A	LEG WELDMENT, REAR, MS
15	1	00014810-A	CROSS BRACE WELDMENT, 5" WHEEL, MS
16	2	05050592	CLEVIS, DOUBLE, .375, 5400# CAP
17	4	05020898	NUT, .375-16, NYLON LOCK, SST, 316
18	2	05050451	WHEEL, CAST IRON, .63 BORE X .188TH X 5 DIA
19	2	05010747	BOLT, .625-11 X 4, G8, HHCS, ZINC
20	8	05021311	WASHER, .625, FLAT, ZINC
21	2	05020837	NUT, .625-11, GC, TOP LOCK, C&W
22	2	05022186	PIN, 1 X 5.75 W/ LANYARD
23	2	00093238-A	BRACKET, SAFETY CHAIN, SKID, 304 MS
24	4	05021307	WASHER, .375, FLAT, ZINC
25	4	05010691	BOLT, .5-13 1.5, HHCS, SST
26	4	05010644	BOLT, .375-16 X 1.25, HHCS, ZINC
27	2	05010737	BOLT, .625-11 X 1.5, HHCS, ZINC
30	2	00037683	CHAIN, .375-96
31	2	00094299-A	TAB WELDMENT, SLIDE, SAFETY CHAIN, LH, 304 MS
32	2	00094293-A	TAB WELDMENT, SLIDE, SAFETY CHAIN, RH, 304 MS
33	2	05052558	DECAL, WARNING SKID

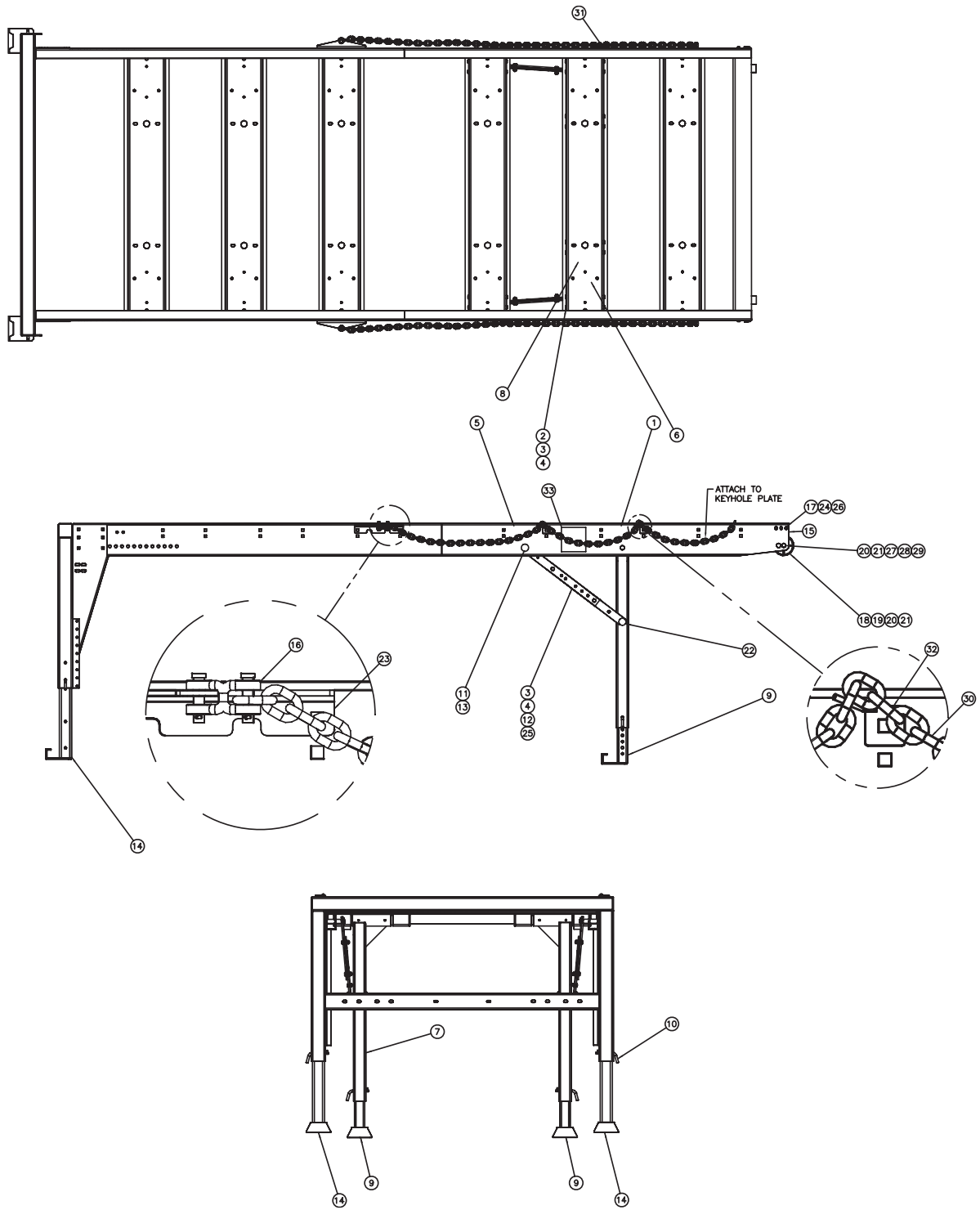

00083799-B LEG KIT

Item	Qty	Part Number	Description
1	4	00071356-B	MOUNT WELDMENT, FRONT, BOLT-ON, SST
2	24	05016045	BOLT, ½-13 X 1¼, G8, HHCS, ZINC
3	28	05021391	WASHER, ½, FLAT, ZINC
4	28	05020908	NUT, ½-13, GC, TOP LOCK, C&W
5	2	00056190-B	MOUNT, LEG, RAIL, BOLT-ON, SST
6	2	00071397	PIPE, 2 SCHED 40 X 18
7	2	00085111-B	LEG WELDMENT, FRONT, OUTER, SST
8	4	05050003	GREASE ZERK, ½ NPT, STRAIGHT
9	2	00083798-B	LEG WELDMENT, INNER, FRONT, SST
10	4	05022136	PIN, ½ X 4½, 4" GRIP BENT, MS
11	4	05022077	PIN, 1 X 4½, BUTTON HEAD, ZINC
12	4	00082646-B	BRACE PLATE, LEG, FRONT, SST
13	4	05022106	PIN, .188 LYNCH
14	2	00085104-B	LEG WELDMENT, REAR, SST
15	1	00014810-B	CROSS BRACE WELDMENT, 5" WHEEL, SST
16	2	05050592	CLEVIS, DOUBLE, .375, 5400# CAP
17	4	05020891	NUT, .375-16, NYLON LOCK, SST, 316
18	2	05050451	WHEEL, CAST IRON, .63 BORE X .188TH X 5 DIA
19	2	05010747	BOLT, .625-11 X 4, G8, HHCS, ZINC
20	8	05021311	WASHER, .625, FLAT, ZINC
21	2	05020837	NUT, .625-11, GC, TOP LOCK, C&W
22	2	05022186	PIN, 1 X 5.75 W/ LANYARD
23	2	00093238-B	BRACKET, SAFETY CHAIN, SKID, 304 SST
24	4	05021390	WASHER, .375, FLAT, SST
25	4	05016096	BOLT, .5-13 1.5, HHCS, SST
26	4	05016049	BOLT, .375-16 X 1.25, HHCS, SST
27	2	05016248	BOLT, .625-11 X 1.5, HHCS, SST
28	2	05021406	WASHER, .625, FLAT, SST
29	2	05020903	NUT, .625-11, NYLON LOCK, SST
30	2	00037683	CHAIN, .375-96
31	2	00094299-B	TAB WELDMENT, SLIDE, SAFETY CHAIN, LH, 304 SST
32	2	00094293-B	TAB WELDMENT, SLIDE, SAFETY CHAIN, RH, 304 SST
33	2	05052558	DECAL, WARNING SKID

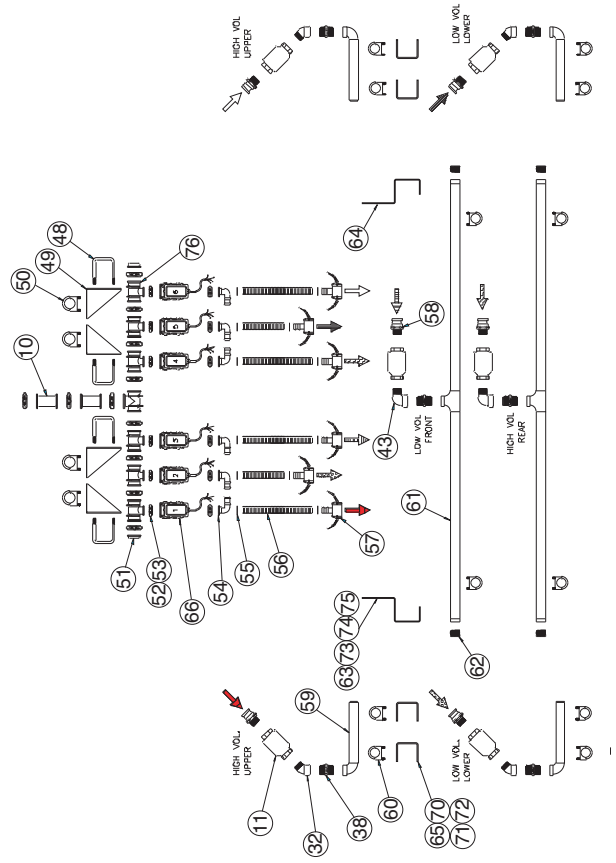
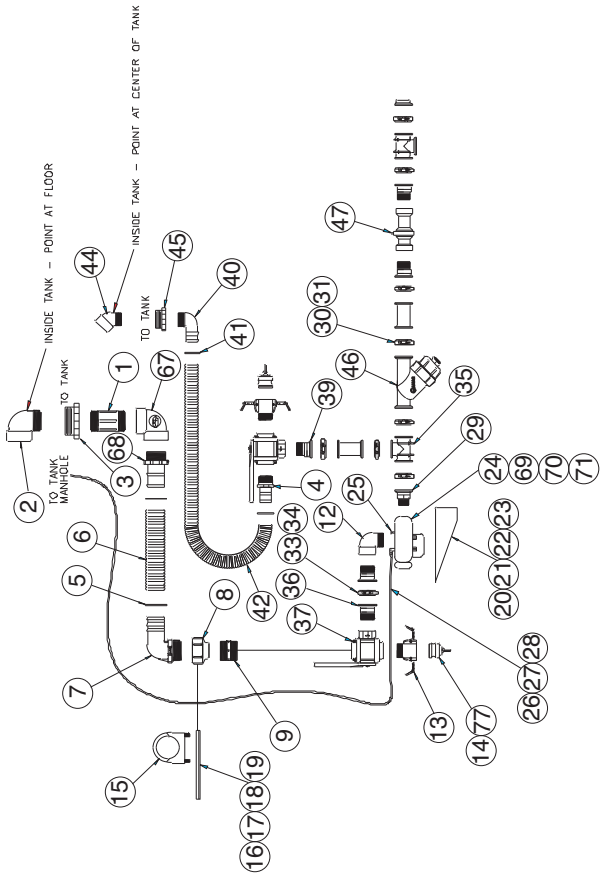

00071389-A PLUMBING KIT, LIQUID, TIERED, 3L, 1.5" BOOM, MS

ITEM	QTY	PART #	DESCRIPTION
1	1	05038158	Coupling, Reducer, 3 x 2, Poly
2	1	05037390	Nipple, 2" NPT, Short, Poly
3	3	05037919	Coupling, Manifold, Poly, 2" Flange x 2" Flange
4	1	05037443	Elbow, 2" Poly, Street, 90°
5	1	05037380	Coupler, Poly, Cam Levers, 2" MNPT x Female
6	2	05037382	Plug, Poly, 2" Female Coupler
7	1	05050466	Clamp, Muffler, U-Type, SST
8	1	00056141-A	Bracket, Mounting, Plumbing, MS
9	2	05010593	Bolt, ¼-20 x 1, G8, HHCS, Zinc
10	4	05021305	Washer, ¼, Flat, Zinc
11	2	05020899	Nut, ¼-20, Top Lock, Zinc
12	1	00042699-A	Bracket, Mounting, Pump, MS
13	2	05010691	Bolt, ½-13 x 1½, G8, HHCS, Zinc
14	4	05021005	Washer, ½, Flat, Mil-Carb, SAE, Zinc
15	2	05020847	Nut, ½-13, GC, Top Lock, C&W
16	1	05008009	Pump, Liquid, 2" FNPT x 1½" FNPT, Hypro (See page 50-51)
17	1	05037631	Drain Cock, ½" NPT, Brass
18	5	05050686	Cable Tie, HD, 8" L x .180" W, Black
19	1	05038489	Adapter, 90°, Brass, ½" NPT x ¾" OD Air
20	11 FT	05050804	Air Line, ¾" OD, Black
21	1	05037745	Nipple, Manifold 11/2" MNPT x 2" Flange, Straight, Poly
22	20	05037907	Gasket, Flange, EPDM, Manifold
23	20	05037748	Clamp, Flange, SS
24	1	05038072	Gasket, Flange, EPDM, 2"
25	1	05038070	Clamp, Flange, SS
26	2	05037772	Tee, Manifold, 2" Flange x 2" Flange x 2" Flange
27	2	05038068	Nipple, Manifold, 2" MNPT x 2" Flange, Straight
28	1	05037394	Valve, 3-Way Ball Type, 2" FNPT, Poly
29	2	05037744	Nipple, Manifold, 2" MNPT x 2" Flange, Straight
30	1	05037910	Strainer, Y-Type, 2" Manifold, Poly, w/6Mesh (See page 52)
31	1	05040086	Meter, Flow 2" FNPT (See page 49)
32	4	00037725	U-Bolt, 3½ x 5
33	4	00050943-A	Bracket, Mounting, Electric Valve, MS
34	4	05050616	Clamp, Muffler, U-Type, 2¼" SST
35	2	05037753	Plug, Manifold, 2" Flange, Poly
36	12	05038270	Gasket, Flange, EPDM
37	12	05037774	Clamp, Flange, SS
38	6	05038199	Elbow, Manifold, 90°, 1" Flange x 1¼" Barb
39	12	05050708	Clamp, 1¼", T-Bolt, 1¼" ID Hose, SS
40	23 FT	05038157	Hose, 1¼" Black Ribbed, EPDM
41	6	05038175	Coupler, Poly, Cam, 1¼" Barb x 1½" Female
42	6	05037750	Valve, Manifold, 1" Flange, Poly
43	2	05010645	Bolt, ⅜-16 x 1½, G8, HHCS, Zinc
44	4	05021307	Washer, ⅜, Flat, Zinc
45	2	05020898	Nut, ⅜-16, GC, Top Lock, C&W
46	6	05037751	Tee, Manifold, 2" Flange x 2" Flange x 1" Flange
47	2	05050763	Cable Tie, Standard, 15.5" L x .18" W, Black, 50lb
48	1	05038611	Cross, 2" Poly, Manifold
49	1	05037770	Valve, Manifold, 2" MNPT x 2" Flange, Poly
50	1	05037467	Coupler, Poly, Cam Lever, 2" FNPT x Female
51	1	05037747	Valve, Manifold, 2" Flange, Poly
52	1	05038627	Plug, Manifold, 2" Flange, ¼" FNPT
53	1	05050995	Plug, ¼" NPT, Poly

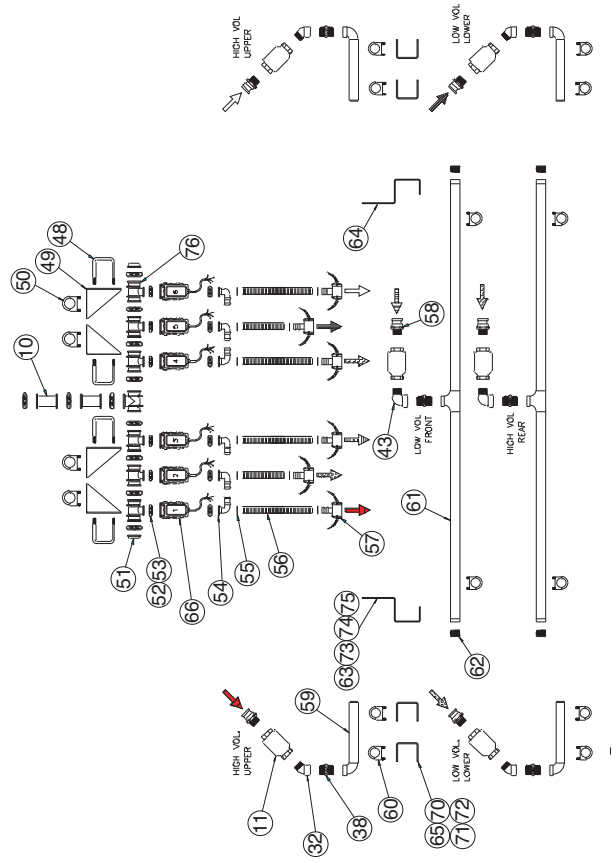
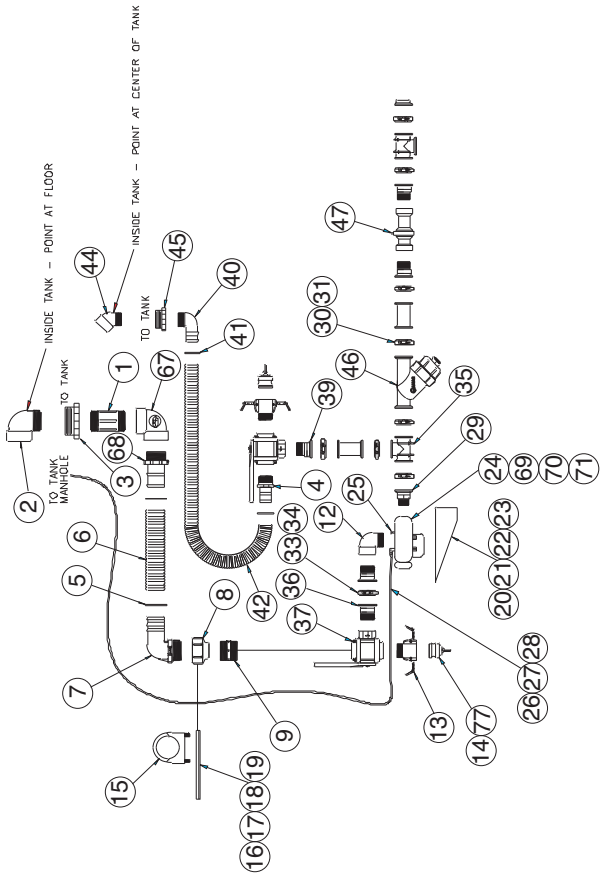

00071389-B PLUMBING KIT, LIQUID, TIERED, 3L, 1.5" BOOM, SST

ITEM	QTY	PART #	DESCRIPTION
1	1	05038158	Coupling, Reducer, 3 x 2, Poly
2	1	05037390	Nipple, 2" NPT, Short, Poly
3	3	05037919	Coupling, Manifold, Poly, 2" Flange x 2" Flange
4	1	05037443	Elbow, 2" Poly, Street, 90°
5	1	05037380	Coupler, Poly, Cam Levers, 2" MNPT x Female
6	2	05037382	Plug, Poly, 2" Female Coupler
7	1	05050466	Clamp, Muffler, U-Type, SST
8	1	00056141-B	Bracket, Mounting, Plumbing, SST
9	2	05016040	Bolt, ¼-20 x 1, HHCS, SST
10	4	05021403	Washer, ¼, Flat, SST
11	2	05020906	Nut, ¼-20, Nylon Lock, SST
12	1	00042699-B	Bracket, Mounting, Pump, SST
13	2	05016096	Bolt, ½-13 x 1½, HHCS, SST
14	4	05021391	Washer, ½, Flat, SST
15	2	05020908	Nut, ½-13, Nylon Lock, SST
16	1	05008009	Pump, Liquid, 2" FNPT x 1½" FNPT, Hypro (See page 50-51)
17	1	05037631	Drain Cock, ½" NPT, Brass
18	5	05050686	Cable Tie, HD, 8" L x .180" W, Black
19	1	05038489	Adapter, 90°, Brass, ½" NPT x ¾" OD Air
20	11 FT	05050804	Air Line, ¾" OD, Black
21	1	05037745	Nipple, Manifold 11/2" MNPT x 2" Flange, Straight, Poly
22	20	05037907	Gasket, Flange, EPDM, Manifold
23	20	05037748	Clamp, Flange, SS
24	1	05038072	Gasket, Flange, EPDM, 2"
25	1	05038070	Clamp, Flange, SS
26	2	05037772	Tee, Manifold, 2" Flange x 2" Flange x 2" Flange
27	2	05038068	Nipple, Manifold, 2" MNPT x 2" Flange, Straight
28	1	05037394	Valve, 3-Way Ball Type, 2" FNPT, Poly
29	2	05037744	Nipple, Manifold, 2" MNPT x 2" Flange, Straight
30	1	05037910	Strainer, Y-Type, 2" Manifold, Poly, w/6Mesh (See page 52)
31	1	05040086	Meter, Flow 2" FNPT (See page 49)
32	4	00037725	U-Bolt, 3½ x 5
33	4	00050943-B	Bracket, Mounting, Electric Valve, SST
34	4	05050616	Clamp, Muffler, U-Type, 2¼" SST
35	2	05037753	Plug, Manifold, 2" Flange, Poly
36	12	05038270	Gasket, Flange, EPDM
37	12	05037774	Clamp, Flange, SS
38	6	05038199	Elbow, Manifold, 90°, 1" Flange x 1¼" Barb
39	12	05050708	Clamp, 1¼", T-Bolt, 1¼" ID Hose, SS
40	23 FT	05038157	Hose, 1¼" Black Ribbed, EPDM
41	6	05038175	Coupler, Poly, Cam, 1¼" Barb x 1½" Female
42	6	05037750	Valve, Manifold, 1" Flange, Poly
43	2	05016162	Bolt, ⅜-16 x 1½, G8, HHCS, Zinc
44	4	05021418	Washer, ⅜, Flat, Zinc
45	2	05020891	Nut, ⅜-16, GC, Top Lock, C&W
46	6	05037751	Tee, Manifold, 2" Flange x 2" Flange x 1" Flange
47	2	05050763	Cable Tie, Standard, 15.5" L x .18" W, Black, 50lb
48	1	05038611	Cross, 2" Poly, Manifold
49	1	05037770	Valve, Manifold, 2" MNPT x 2" Flange, Poly
50	1	05037467	Coupler, Poly, Cam Lever, 2" FNPT x Female
51	1	05037747	Valve, Manifold, 2" Flange, Poly
52	1	05038627	Plug, Manifold, 2" Flange, ¼" FNPT
53	1	05050995	Plug, ¼" NPT, Poly

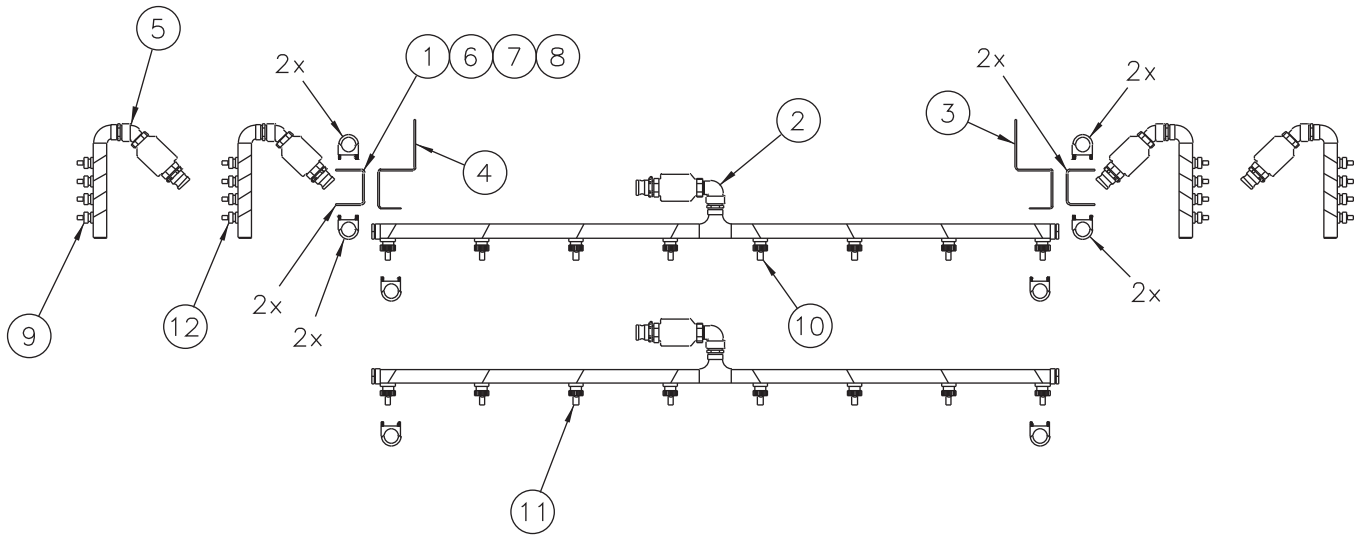

00017121 BOOM ASSEMBLY, 2T, 3 LANE

Item	Qty	Part Number	Description
1	4	00050987-A	Bracket, Mounting, MS
	4	00050987-B	Bracket, Mounting, SST
2	2	00016625	Spray Boom Kit, Center (See page 41)
3	1	00037157-A	Hanger, Spray Boom, RH, MS
	1	00037157-B	Hanger, Spray Boom, RH, SST
4	1	00037158-A	Hanger Spray Boom, LH, MS
	1	00037158-B	Hanger Spray Boom, LH, SST
5	4	00083329	Spray Boom Kit, Side Lane (See page 42)
6	12	05016049	Bolt, $\frac{3}{8}$ -16 x 1 $\frac{1}{4}$, HHCS, SST
7	24	05021390	Washer, $\frac{3}{8}$, Flat, SST
8	12	05020891	Nut, $\frac{3}{8}$ -16, Nylon Lock, 316 SST
9	8	00084623	Nozzle Kit, 1 $\frac{1}{2}$ ", 2GPM@40PSI, $\frac{1}{4}$ " NPT (See page 43)
10	8	00084624	Nozzle Kit, 1 $\frac{1}{2}$ " 1 GPM@40PSI, $\frac{1}{4}$ " NPT (See page 44)
11	8	00081779	Nozzle Kit, 1 $\frac{1}{2}$ " 6GPM@40PSI, $\frac{1}{4}$ " NPT (See page 43)
12	8	00081778	Nozzle Kit, 1 $\frac{1}{2}$ " 12GPM@40PSI, $\frac{3}{8}$ " NPT (See page 43)

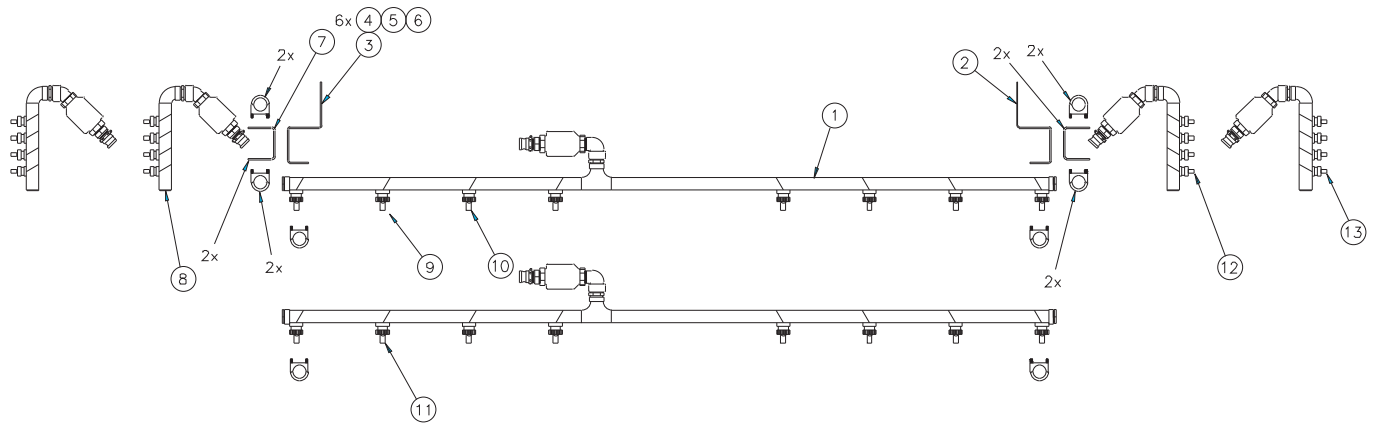

00081780 BOOM ASSEMBLY, 2T, 3LANE

Item	Qty	Part Number	Description
1	2	00016625	Spray Boom Kit, Center (See page 41)
2	1	00037157-A	Spray Boom Hanger, RH, MS
	1	00037157-B	Spray Boom Hanger, RH, SST
	1	00037157-C	Spray Boom Hanger, RH, Ausst
3	1	00037158-A	Spray Boom Hanger, LH, MS
	1	00037158-B	Spray Boom Hanger, LH, SST
	1	00037158-C	Spray Boom Hanger, LH, Ausst
4	12	05016049	Bolt, 3/8-16 x 1 1/4, HHCS, SST
5	24	05021390	Washer, 3/8, Flat, SST
6	12	05020891	Nut, 3/8-16, Nylon Lock, SST
7	4	00050987-A	Bracket, Mounting, MS
	4	00050987-B	Bracket, Mounting, SST
	4	00050987-C	Bracket, Mounting, Ausst
8	4	00083329	Spray Boom Kit, Side Lane (See page 42)
9	4	00081777	Nozzle Kit, 1 1/2, 1/4" NPT Plug (See page 44)
10	4	00081776	Nozzle Kit, 1 1/2, 2GPM (See page 44)
11	8	00081775	Nozzle Kit, 1 1/2 .129" Orifice (See page 45)
12	8	00081774	Nozzle Kit, 1 1/2, 2GPM (See page 45)
13	8	00081773	Nozzle Kit, 1 1/2, 6GPM (See page 45)

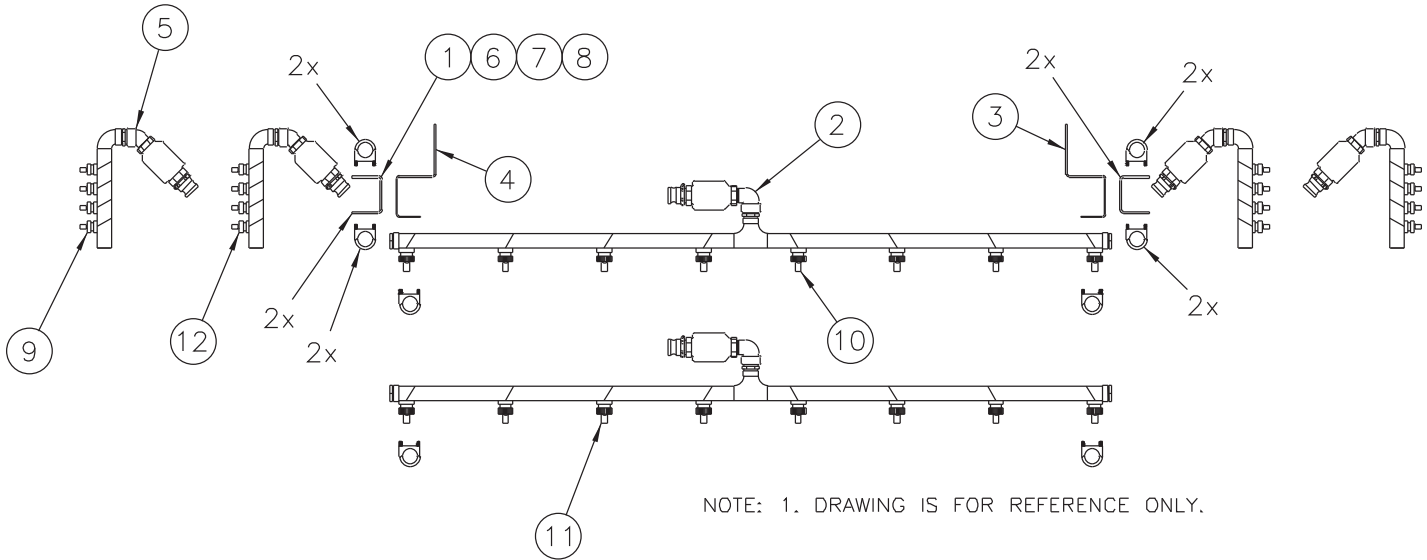

00017392 BOOM ASSEMBLY, 2T, 3LANE

Item	Qty	Part Number	Description
1		00050987-A	Bracket, Mounting, Tiered, MS
		00050987-B	Bracket, Mounting, Tiered, SST
2		00016625	Spray Boom Kit, Center (See page 41)
3		00037157-A	Hanger, Spray Boom, RH, MS
		00037157-B	Hanger, Spray Boom, RH, SST
4		00037158-A	Hanger, Spray Boom, LH, MS
		00037158-B	Hanger, Spray Boom, LH, SSTS
5		00083329	Spray Boom Kit, Side Lane (See page 42)
6		05016049	Bolt, $\frac{3}{8}$ -16 x $1\frac{1}{4}$, HHCS, SST
7		05021390	Washer, $\frac{3}{8}$, Flat, SST
8		05020891	Nut, $\frac{3}{8}$ -16, Nylon Lock, SST
9		00084623	Nozzle Kit, $1\frac{1}{2}$ ", 2GPM (See page 43)
10		00084624	Nozzle Kit, $1\frac{1}{2}$ ", 1GPM (See page 44)
11		00081776	Nozzle Kit, $1\frac{1}{2}$ ", 2GPM, Straight (See page 44)
12		00016623	Nozzle Kit, $1\frac{1}{2}$ ", 4GPM (See page 45)

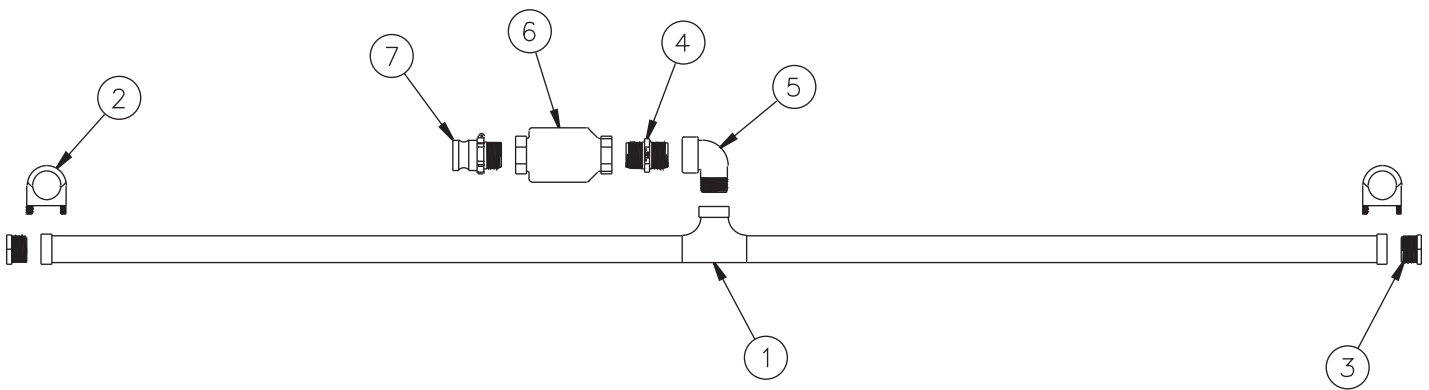

00016625 SPRAY BOOM, CENTER

Item	Qty	Part Number	Description
1	1	00050986	Boom Weldment, Spray, Center Tiered
2	2	05050542	Clamp, Muffler, U-Type, SS
3	2	05037763	Plug, 1½" NPT, Poly
4	1	05037440	Nipple, 1½" NPT, Short, Poly
5	1	05037433	Elbow, 1½" NPT, Poly, Street
6	1	05037905	Valve, In-Line Chack, ½"
7	1	05037917	Coupler, Poly, Cam, 1½" MNPT x 1½" Male

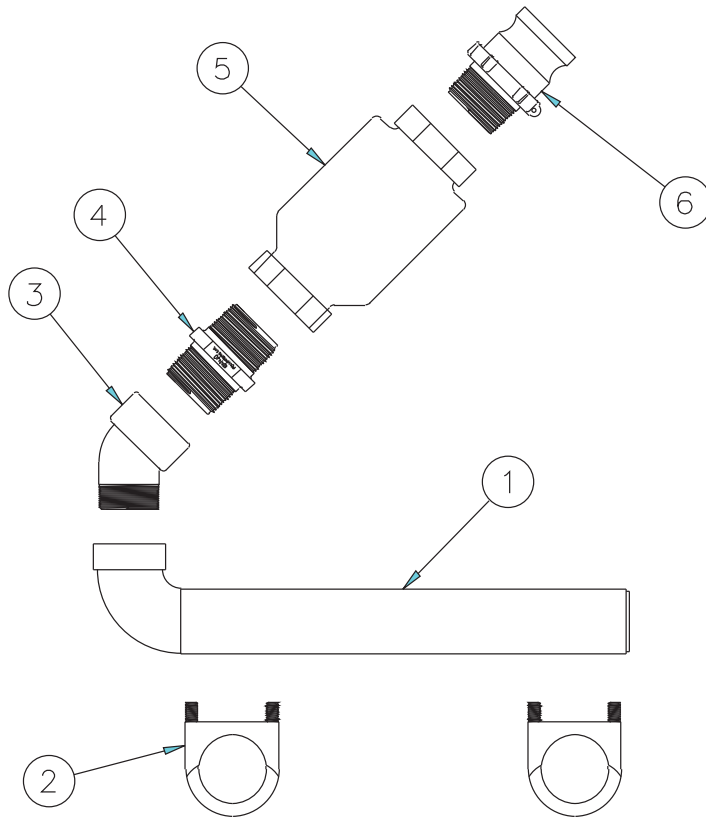

00083329 SPRAY BOOM KIT, SIDE LANE, 1 1/2" SST

Item	Qty	Part Number	Description
1	1	00050984	Boom Weldment, Spray Side Tiered
2	2	05050542	Clamp, Muffler, U-Type, 2 SST
3	1	05038310	Elbow, 1 1/2 NPT Poly, Street, 45°
4	1	05037440	Nipple, 1 1/2 NPT, Short Poly
5	1	05037905	Valve, In-Line Check, 1 1/2 NPT
6	1	05037917	Coupler, Poly, Cam, 1 1/2" MNPT x 1 1/2" Male

00081778 NOZZLE KIT, 1½", 12GPM@40PSI, ⅜"

Item	Qty	Part Number	Description
1	1	05038187	Nozzle Body, Poly, Clip-On, w/ Cap
2	1	05038185	Nozzle, Brass, ⅜" MNPT, 12GPM@40PSI
3	1	05038189	Ball, Clip-On Nozzle w/ ⅜ FNPT Thread
4	1	05050608	Cable Tie, HD, 14"L x .30" W, Black

00081779 NOZZLE KIT, 1½", 6GPM@40PSI, ¼" NPT, BRASS

Item	Qty	Part Number	Description
1	1	05037409	Nozzle Assembly, Plastic, K-Ball, Clip-On
2	1	05038186	Nozzle, Brass, ¼" MNPT, 6GPM@40PSI, Solid
3	1	05050608	Cable Tie, HD, 14"L x .30" W, Black

00084623 NOZZLE KIT, 1½", 2GPM

Item	Qty	Part Number	Description
1	1	05038180	Nozzle Body, Brass, ¼ MNPT
2	1	05038179	Nozzle Cap, Brass,
3	1	05037995	Valve, Nozzle, Check
4	1	05038183	Nozzle, tip, Brass
5	1	05038187	Nozzle Body, Poly
6	1	05038188	Ball, Clip-On
7	1	05050608	Cable Tie

00084624 NOZZLE KIT, 1 1/2", 1GPM

Item	Qty	Part Number	Description
1	1	05037409	Nozzle Assembly, Plastic
2	1	05038180	Nozzle Body, Brass
3	1	05038179	Nozzle Cap, Brass
4	1	05037995	Valve, Nozzle Check
5	1	05038182	Nozzle, Tip Brass
6	1	05050608	Cable Tie

00081777 NOZZLE KIT, 1 1/2, W/ 1/4" NPT PLUG

Item	Qty	Part Number	Description
1	1	05050995	Plug, 1/4" NPT
2	1	05037409	Nozzle Assembly, Plastic
3	1	05050608	Cable Tie

00081776 NOZZLE KIT, 1 1/2, 2GPM 1/4" NPT

Item	Qty	Part Number	Description
1	1	05038410	Nozzle Brass, 1/4" MNPT
2	1	05037409	Nozzle Assembly, Plastic
3	1	05050608	Cable Tie

00081775 NOZZLE KIT, 1 1/2", .129" ORIFICE

Item	Qty	Part Number	Description
1	1	05037456	Nozzle Brass, 1/4" MNPT
2	1	05037409	Nozzle Assembly, Plastic
3	1	05050608	Cable Tie

00081774 NOZZLE KIT, 1 1/2", 2GPM

Item	Qty	Part Number	Description
1	1	05038410	Nozzle Brass, 1/4" MNPT
2	1	05038187	Nozzle Body, Poly
3	1	05038188	Ball, Clip-On, Nozzle
4	1	05050608	Cable Tie

00081773 NOZZLE KIT, 1 1/2", 6GPM

Item	Qty	Part Number	Description
1	1	05038186	Nozzle Brass, 1/4" MNPT
2	1	05038187	Nozzle Body, Poly
3	1	05038188	Ball, Clip-On, Nozzle
4	1	05050608	Cable Tie

00016623 NOZZLE KIT, 1/2", 4GPM

Item	Qty	Part Number	Description
1	1	05038187	Nozzle Body
2	1	05038188	Ball, Clip-On
3	1	05038180	Nozzle Body
4	1	05038358	Nozzle Tip
5	1	05038179	Nozzle Cap
6	1	05050608	Cable Tie

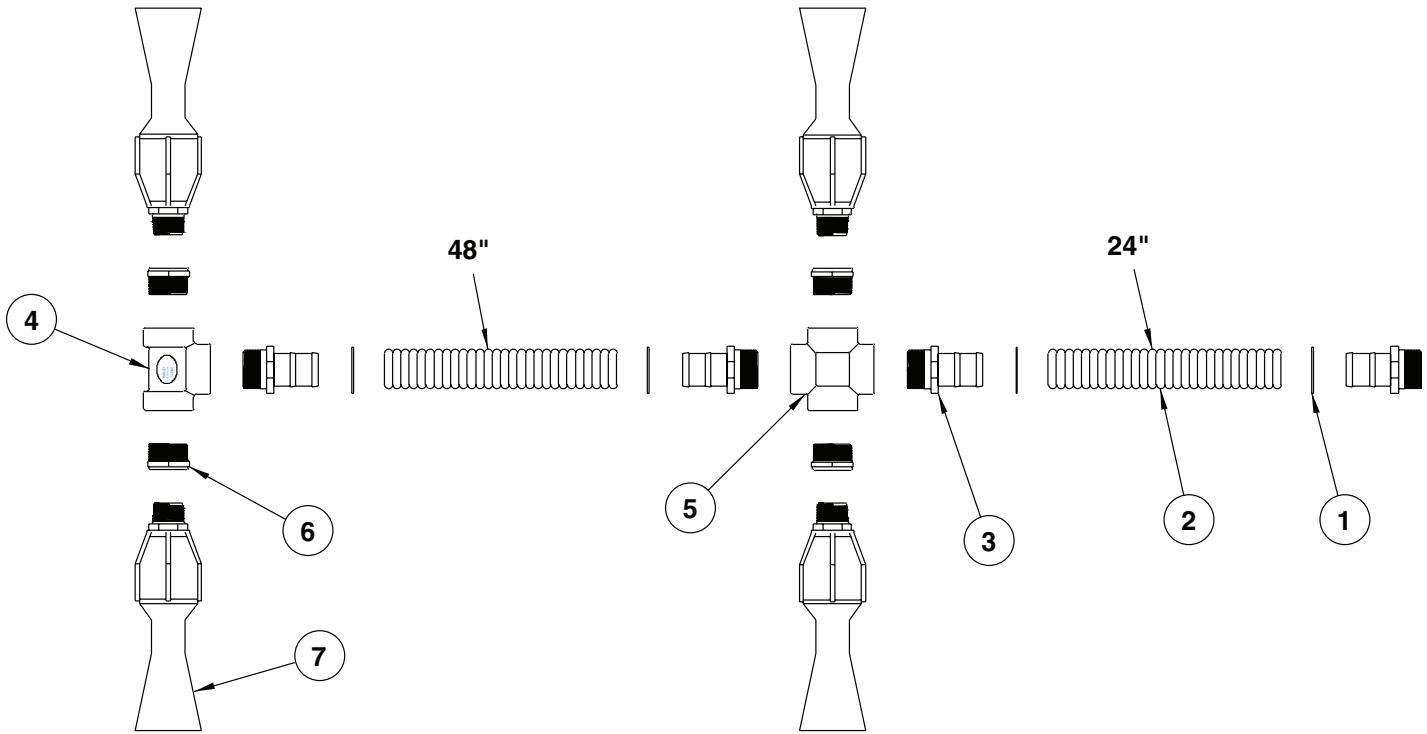

NOTE: 1. DRAWING IS FOR REFERENCE ONLY.

00016594 AGITATION KIT

Item	Qty	Part Number	Description
1	4	05050615	Clamp, 2" T-Bolt, SS
2	6FT	05037577	Hose, 2" ID, Black Ribbed, EPDM
3	4	05037386	Hose Barb, 2" x 2" MNPT, Poly
4	1	05037392	Tee, 2" Female NPT, All Ports
5	1	05037444	Cross, 2", Poly
6	4	05037441	Bushing, Reducer, 2" MNPT x 1½" FNPT
7	4	05038526	Nozzle Eductor, Poly

00012978 CONTROL/HARNESS KIT, DLA 336

Item	Qty	Part Number	Description
1	1	05040312	Console Assembly, Raven DLA 336
2	1	05040191	Cable Assembly, Truck Portion
3	1	05040190	Cable Assembly, Spreader Portion
4	1	00047931	Mounting Plate, Connector, Cable

00048832 SENSOR KIT, LOW LEVEL

Item	Qty	Part Number	Description
1	1	05041150	Switch, Low Level Sensor, Polypropylene
2	1	05041267	Light, Indicator, Red, MO Control Panel
3	40 FT	05041313	Cable, Wire, 14GA/ 2 Conductor, .295" OD
4	1	05041353	Weather Pack, Shroud Half, 2 Contact
5	2	05041352	Weather Pack, Tower Half, 2 Contact
6	4	05041354	Terminal, Male, Packard Weather Pack
7	2	05041355	Terminal, Female, Packard Weather Pack
8	6	05041386	Cavity Seal, Packard Weather Pack 280
9	1	05038362	Fitting, Bulkhead, ½, W/EPDM
10	1	05041475	Panel, MTG

00082879 BAFFLE KIT, TANK, POLY, LEG STYLE

Item	Qty	Part Number	Description
1	1	00082880	Baffle Weldment, Tank, Poly
2	1	00082881	Baffle Weldment, Tank, Poly
3	1	00082887	Bracket Weldment
4	6	05016049	Bolt, $\frac{3}{8}$ -16 x 1 $\frac{1}{4}$, HHCS, SST
5	6	05020891	Nut, $\frac{3}{8}$ -16, Nylon Lock, 316 SST
6	12	05021390	Washer, $\frac{3}{8}$, Flat, SST
7	1	05017000	Bolt, $\frac{1}{2}$ -13 x 6, Carriage, SST
8	1	05020908	Nut, $\frac{1}{2}$ -13, Nylon Lock, SST
9	1	05021391	Washer, $\frac{1}{2}$, Flat, SST

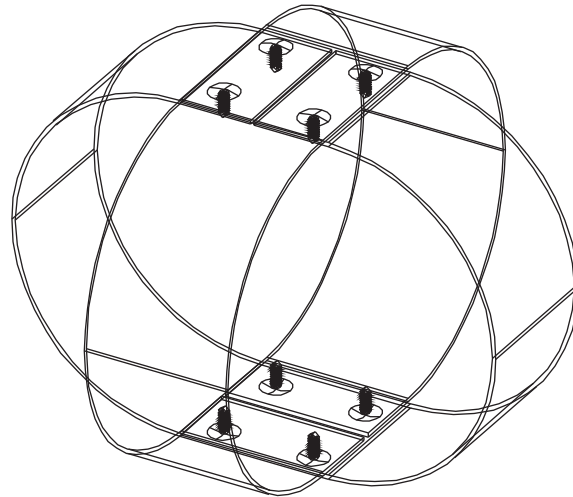
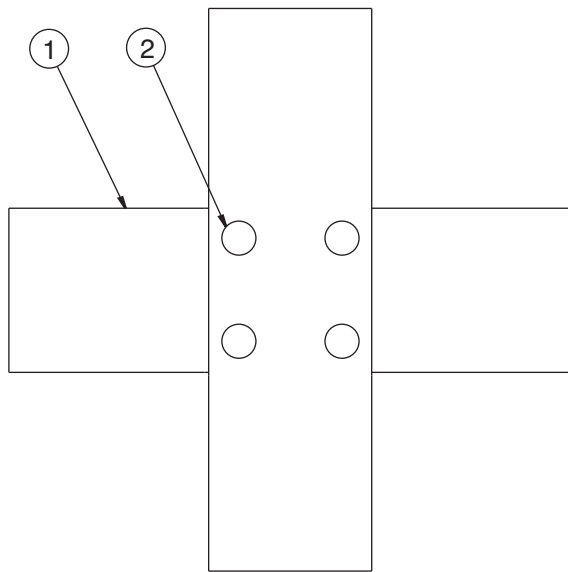

00039276 BAFFLE ASSEMBLY, BALL

Item	Qty	Part Number	Description
1	2	00039275	Band, Baffle Ball
2	8	05050512	Clip, Bumper Plastic, $\frac{3}{8}$ " Long

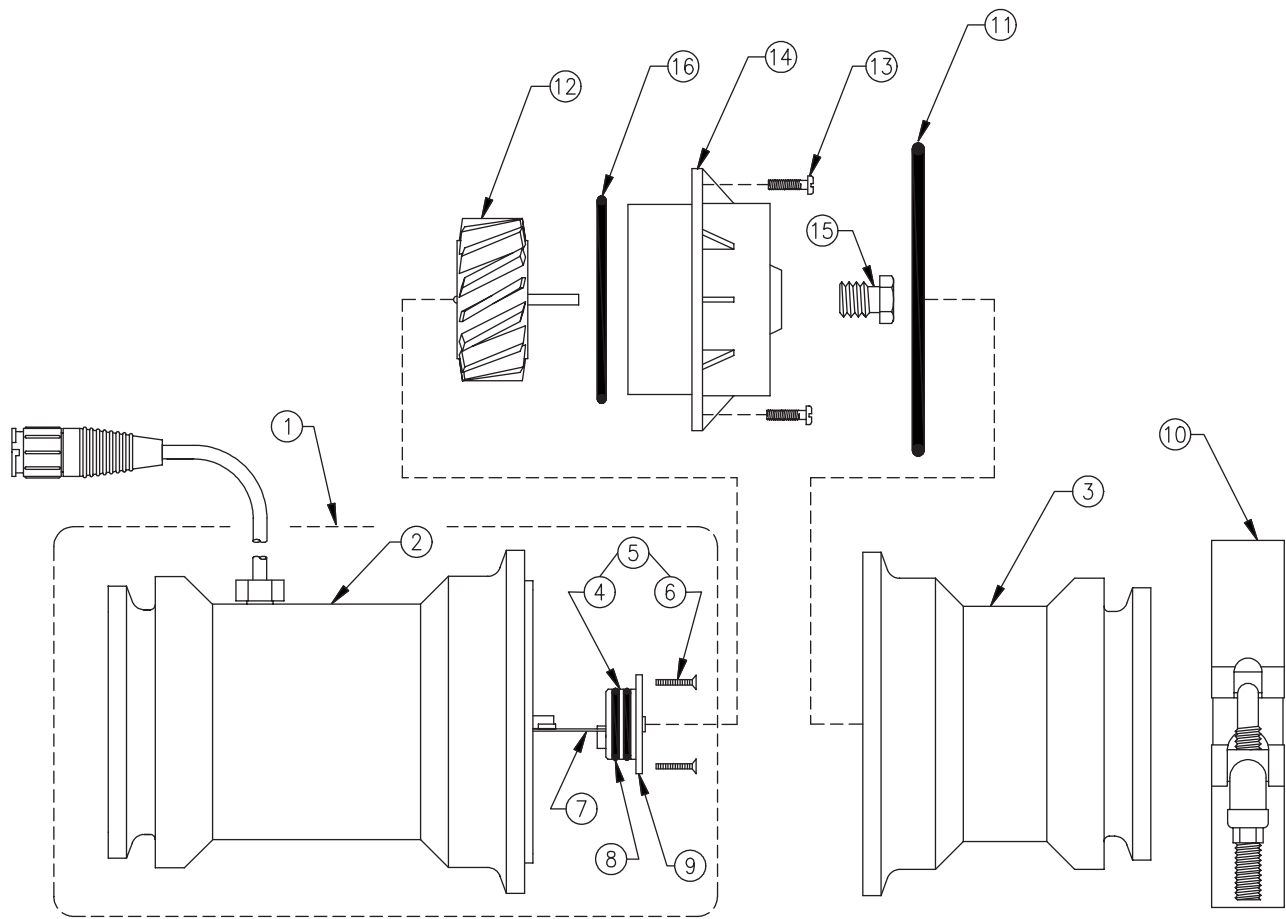

05040086 FLOW METER

Item	Qty	Part Number	Description
1	1	05040110	Outlet Housing Assembly
2	1	05040111	Outlet Housing
3	1	05040112	Hub Housing, Inlet
4	1	05040113	Label, Yellow with Black Arrow
5	1	05040114	End Bearing, P.C. Assembly
6	1	05040115	End Bearing, P.C. Assembly Kit
7	1	05040116	Screw, 2-56 x 1/2", Flat Head, SS
8	1	05040117	P.C. Assembly
9	1	05040118	O-Ring, Viton
10	1	05040119	End Bearing Assembly
11	1	05040120	Clamp, Retaining
12	1	05040121	O-Ring, Viton
13	1	05040122	RFM 100 Turbine
14	1	05040123	Screw, 6-20 x 1/2", Pan Head, SS
15	1	05040124	Turbine Hub/Bearing Assembly
16	1	05040125	Turbine Stud Assembly
17	1	05040126	Bushing, Carbon
18	1	05040127	O-Ring, Viton
19	1	05040128	Thread Sealer <i>(Not Shown)</i>
20	1	05040129	Mounting Bracket, RFM 100 <i>(Not Shown)</i>
21	1	05040130	Clamp, Hose <i>(Not Shown)</i>
22	1	05040131	Cable Kit <i>(Not Shown)</i>

05008009 Pump, Liquid, 2" FNPT x 1½" FNPT, 210 GPM

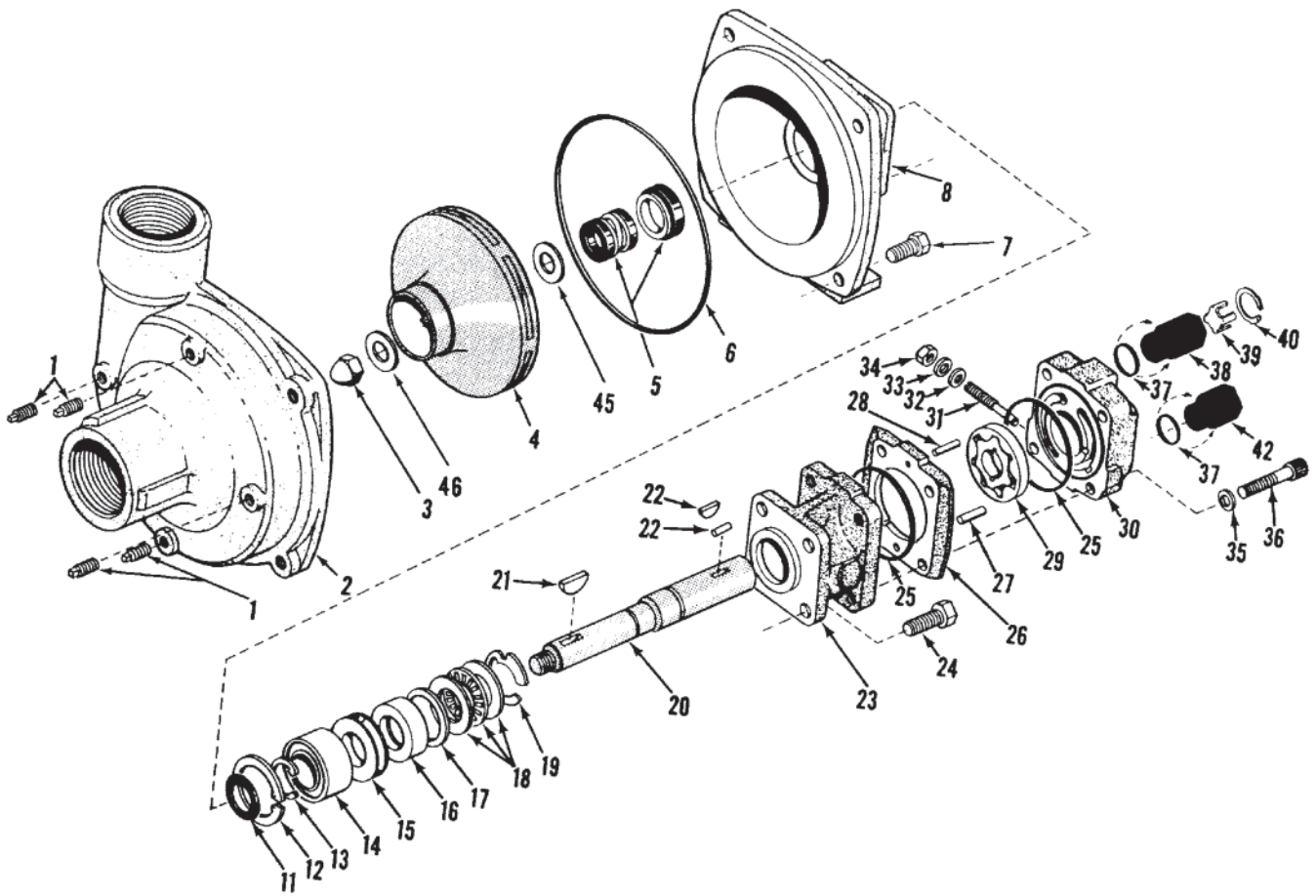

05008009 PUMP PARTS BREAKDOWN

ITEM	QTY	PART #	DESCRIPTION
1	4	05008025	Plug, Drain/Vent
2	1	05008026	Casing, Pump
3	1	05008027	Nut, Impeller
4	1	05008157	Impeller, Cast Iron
5	1	05008029	Mechanical Seal, Viton
6	1	05008030	O-ring
7	4	05008031	Capscrew, Hex Head
8	1	05008032	Mounting Flange
11	1	05008033	Ring, Slinger
12	1	05008034	Ring, Retaining
13	1	05008035	Ring, Snap
14	1	05008036	Ball Bearing
15	1	05008037	Spacer
16	1	05008038	Seal, Shaft
17	1	05008039	Spacer, Seal
18	1	05008040	Thrust Bearing Assembly
19	1	05008041	Ring, Snap
21	1	05008042	Key, Woodruff
22	1	05008043	Pin, Roll
23	1	05008044	Front Motor Body (Includes Main Bearing)
24	4	05008045	Capscrew, Hex Head
25	2	05008046	O-ring
26	1	05008047	Housing, Gerotor
27	1	05008048	Pin, Dowel
28	1	05008049	Pin, Dowel
29	1	05008050	Gerotor
30	1	05008051	Motor End Plate (Includes Main Bearing)
31	1	05008052	Screw, Bypass Adjusting
32	1	05008053	Gasket
33	1	05008054	Washer
34	1	05008055	Nut, Lock
35	4	05008056	Washer
36	4	05008057	Capscrew
37	2	05008058	O-ring
38	1	05008059	Adapter, Tank Port
39	1	05008060	Poppet
40	1	05008061	Ring, Retaining
42	1	05008062	Adapter, Pressure Port
45	1	05008063	Gasket, Rubber
46	1	05008064	Washer
47	1	05051536	Seal Kit

NOTE: Items 5,6,and 45 are available as a kit part # 05051536

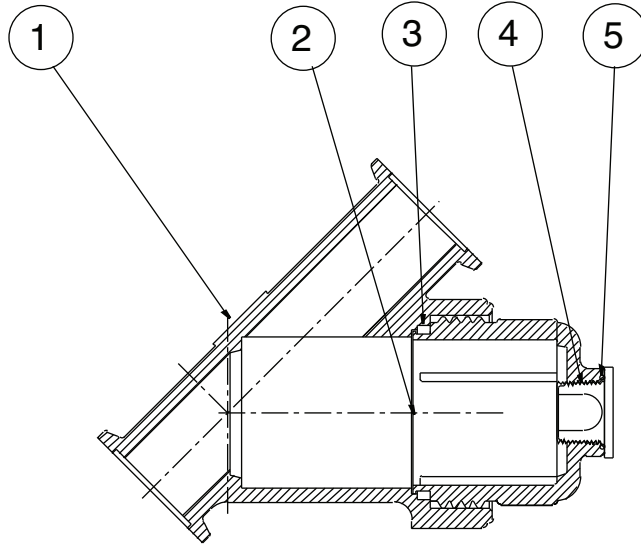

05037910 POLY STRAINER

Item	Qty	Part Number	Description
1	1	05037991	Strainer Body
2	1	05037989	Strainer Cap
3	1	05037676	Strainer Gasket
4	1	05037679	Drain Plug
5	1	05037680	Drain Plug O-Ring

HOW TO ORDER PARTS

To order or inquire about replacement parts, please contact the **distributor** or **store** that the product was purchased through. To speed the information flow, please have the following information ready:

- Model Number
- Serial Number
- Part Number and/or description as per the parts manual
- Quantity needed

For further information about **Monroe Truck Equipment** replacement parts, please call 800-880-0109 and ask for **Snow & Ice Parts Sales**.

RETURN POLICY

Merchandise returned to **Monroe Truck Equipment** must have a Returned Goods Authorization (RGA) form filled out completely and signed by authorized personnel. To get your RGA form, call 800-880-0109. For whole goods, ask for **Snow & Ice Sales**. For replacement parts, ask for **Snow & Ice Parts Sales**. All returned items are subject to a 15% restocking fee and must be sent freight prepaid!

MONROE TRUCK EQUIPMENT, INC. WARRANTY SNOW & ICE CONTROL PRODUCTS

Monroe Truck Equipment, Inc. warrants to the original purchaser, that if any part of the product proves to be defective in workmanship or material within **ONE YEAR** of the original installation, and is returned to us within 30 days of the discovered defect, we will (at our option) repair or replace the defective part. This warranty does not apply to damage resulting from misuse, neglect, accident, improper installation, normal wear items or lack of maintenance. This warranty is exclusive and supersedes all other warranties, whether expressed or implied. **Monroe Truck Equipment, Inc.** neither assumes, nor authorizes anyone to assume for it, any other obligation or liability in connection with this warranty and will not be liable for consequential damages.

All engines, pumps, motors, cylinders and valves are warranted by their manufacturer and not by **Monroe Truck Equipment, Inc.**. The manufacturer's warranty will apply to these parts. Electrical and hydraulic components are not to be disassembled without the express written permission of Monroe Truck Equipment. Use of replacement parts other than original equipment voids this warranty.

All defective parts returned must be accompanied by the model number, serial number, date installed, date of defect, description of defect, and the name of the distributor from whom it was purchased. All warranty claims must have prior written approval from **Monroe Truck Equipment, Inc.**

Please return the warranty registration card that accompanies this manual to confirm receipt of this parts catalog and acknowledge the information contained within. Failure to return the attached card may result in a voided warranty.



1051 West 7th Street
Monroe, WI 53566
608-328-8127 ~ Fax: 608-328-4278

Warranty Policy

Uninstalled Parts and Equipment Provided by Monroe Truck Equipment

Monroe Truck Equipment will provide the following limited warranty for a period of one year to the original purchaser of all uninstalled goods provided by Monroe Truck Equipment:

LIMITED WARRANTY: All goods provided by Monroe Truck Equipment (MTE) will be free from defects in material and workmanship for a period of one year from the date of purchase by the original purchaser. This limited warranty shall be the sole and exclusive remedy for any such product found to be defective. This limited warranty supercedes all previous warranties and is exclusive and in lieu of all other warranties, whether expressed or implied.

This limited warranty applies only to parts or accessories manufactured by MTE and/or provided by same. Except with respect to title, this limited warranty does not pertain to parts or accessories not manufactured and/or provided by MTE, regardless of whether such parts or accessories were selected and/or recommended by MTE. MTE will, as a service to the buyer, pass on any warranties received from the original manufacturer of MTE provided parts and/or accessories.

MTE will not under any circumstances be liable for any incidental or consequential damages whether in tort, contract, or otherwise, for any bodily injury, death, property damage, loss of use, or loss of income resulting from or in any way arising out of any goods provided by MTE, or their sale, use, or manufacture.

Any warranty claim deemed to be arising from the result of misuse, abuse, neglect, accident, improper installation, lack of maintenance, act of war (whether declared or otherwise), or act of God will be denied. Any repair or modification by the buyer or any third party, without the prior written consent of MTE, will void any possible warranty compensation. Any damage deemed to be the result of abnormal operation will not be compensated by this warranty.

Normal or special maintenance items such as fuels, fluids, tires, belts, hoses, filters, air cleaners, light bulbs, and any other items subject to normal wear and tear that are supplied in connection with goods provided by MTE are not allowed under this warranty.

All engines, pumps, cylinders, valves, and motors are warranted by their manufacturer and not by Monroe Truck Equipment. The manufacturer's warranty will apply to these parts. Electrical and hydraulic components are not to be disassembled without the express written consent of MTE. Any disassembly of MTE provided components without prior authorization will void the applicable warranty.

Monroe Truck Equipment shall be the sole and final determining authority as it applies to the administration of this warranty policy. Purchaser acknowledges receipt of Monroe Truck Equipment Warranty Policy and agrees to be bound by same.



GLOBAL SOLUTIONS
ARMORED VEHICLES ~ SPORT TRUCK CONVERSIONS
MUNICIPAL SNOW & ICE CONTROL ~ FIRE APPARATUS
PICKUP TRUCK ACCESSORIES ~ TRUCK EQUIPMENT/MODIFICATIONS





1051 West 7th Street
Monroe, WI 53566
608-328-8127 ~ Fax: 608-328-4278

Any and all warranty claims must be forwarded to MTE within 10 days of defect discovery. A copy of the original Monroe Truck Equipment invoice as well as the manufacturer's model number, serial number, and date of installation must accompany all correspondence regarding said claims. MTE will, at their option, choose whether to repair or replace the defective part unless otherwise specified by the original manufacturer of said part.

Procedures for Warranty Claims Notification

For submission of any warranty claim please contact Monroe Truck Equipment – Warranty Department at 800-356-8134

The following documentation will be needed when you call for initial warranty authorization:

1. A copy of the original MTE invoice.
2. Make, Model, and VIN or Serial Number of the equipment involved.
3. Part number and serial number of the part in question.
4. A complete description of the problem.

The following must accompany any claim submitted to Monroe Truck Equipment:

1. Documented photographs of any physical damage.
2. Inspection notes by MTE personnel or MTE authorized 3rd party.
3. Authorization number issued by Monroe Truck Equipment – Warranty Department.

Defective parts must be returned to Monroe Truck Equipment (freight prepaid) within 30 days of issuance of Authorization Number.

Monroe Truck Equipment reserves the right to void any warranty for failure to comply with Monroe Truck Equipment Warranty Policy.

This policy is effective October 11, 2012

