



Full Trip One-Way Plow

Service and Parts Manual



MONROE TRUCK EQUIPMENT
1051 W. 7th Street
Monroe, WI 53566
Phone: 608-328-8127
Fax: 608-329-8488

05051949-9
2/5/2016

TABLE OF CONTENTS

SAFETY INSTRUCTIONS	Page 2
MAINTENANCE INSTRUCTIONS	Page 3
TORQUE CHART	Page 3
GENERAL INFORMATION	Page 4
REPLACEMENT PARTS	Page 6-30
HOW TO ORDER PARTS	Page 33
RETURN POLICY	Page 33
WARRANTY INFORMATION	Page 34-36

SAFETY INSTRUCTIONS

- Read all installation, safety and maintenance instructions completely before operating this equipment.
- Keep all personnel clear of moving parts while equipment is being operated.
- Do not operate a plow in need of maintenance! Repair immediately!
- While operating this equipment use common sense, use caution, be alert and be safety-conscious.



! DANGER

AVOID HIGH-PRESSURE FLUIDS

Escaping fluid under pressure can penetrate the skin causing serious injury.

Avoid the hazard by relieving pressure before disconnecting hydraulic or other lines. Tighten all connections before applying pressure.

Search for leaks with a piece of cardboard. Protect hands and body from high pressure fluids.

If an accident occurs, see a doctor immediately. Any fluid injected into the skin must be surgically removed within a few hours or gangrene may result.



CAUTION: “Stacking” (piling) of snow with a push plow is not recommended.

Raising the plow too high while stacking can damage the plow and mount by causing the lift arm to fold up and contact the moldboard.

Do not lift the plow more than 18” off the ground with piling and stacking snow.

Where possible, start the snow season by pushing snow as far back as possible from the area begin plowed to avoid having to move or stack it later.

MAINTENANCE INSTRUCTIONS

In Season:

- Check for loose bolts and nuts daily, and re-torque before use. (Failure to inspect equipment on a daily basis may seriously affect safety and/or efficiency.)
- Lubricate all grease fittings every ten hours of normal use and more frequently under heavy use.
- A cross over relief valve (30GPM Minimum) MUST be plumbed into the plow reversing circuit. The crossover relief valve pressure settings must NOT exceed 1800psi for 3" reversing cylinder and 1000psi for 4" reversing cylinder.
- Check all hydraulic fittings for tightness on a regular basis.
- System pressure should NOT exceed 2000 PSI.
- Check cutting edge for wear. Do not let cutting edge wear closer than .5" to .375" from the bottom angle of the moldboard.
- Due to the nature of use and environment this equipment is operating in, damage and wear may occur at anytime. Therefore, **Monroe Truck Equipment** recommends the end user

Off Season:

- Use care when disconnecting hydraulic lines to assure that no dirt or foreign objects enter the hydraulic system. Use caps to cover hydraulic hose fittings and insert plugs in hydraulic ports.
- Hydraulic cylinders should be fully retracted when stored during the off season to prevent damage or corrosion. The remaining exposed shaft surface should be coated with a thick grease to prevent corrosion, which must be removed before returning to regular service.
- Check mounting bolts for wear and/or damaged threads and replace before next season.

GENERAL INFORMATION

- Location descriptions are noted in direction of travel. (i.e. front, rear, left and right.)
- Delivery of replacement parts is subject to our sales delivery terms.
- Use only **Monroe Truck Equipment** O.E.M. replacement parts. Failure to do so will void warranty.
- Replacement parts listed in this manual reflect our most common plow items. If you do not find the part you require, please call your distributor.
- **Monroe Truck Equipment** reserves the right to make revisions or alterations to this parts manual without notice.

NOTES

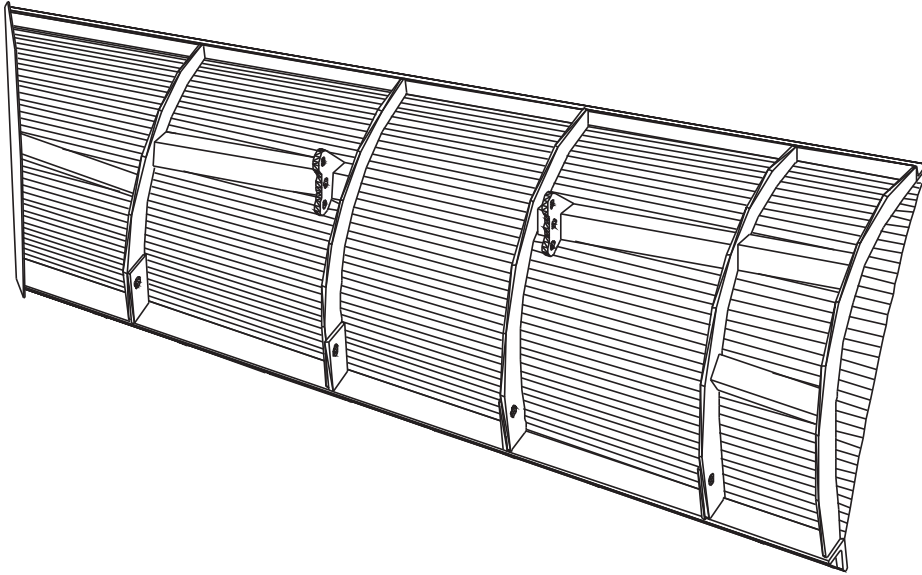

FIXED ANGLE FULL TRIP ONE-WAY PLOW

ITEM	QTY	PART #	DESCRIPTION
1	1	01121201 01121204 01121202 01121205 01121208 01121209 01121206	Moldboard Weldment, Plow, MP30-47-10-IS Moldboard Weldment, Plow, MP39-52-10-IS Moldboard Weldment, Plow, MP30-47-11-IS Moldboard Weldment, Plow, MP39-52-11-IS Moldboard Weldment, Plow, MP30-60-11-IS Moldboard Weldment, Plow, MP30-60-12-IS Moldboard Weldment, Plow, MP39-52-12-IS



CUTTING EDGE KIT

ITEM	QTY	PART #	DESCRIPTION
1	1	05031012	Cutting Edge, 5/8" X 8" X 10', TPCS <i>(Shown above)</i>
		05031013	Cutting Edge, 5/8" X 8" X 11', TPCS
		05031014	Cutting Edge, 5/8" X 8" X 12', TPCS
2	12	05014551	Bolt, 5/8"-11 X 2 1/2", G8, DH, Plain, 10'
	13	05014551	Bolt, 5/8"-11 X 2 1/2", G8, DH, Plain, 11'
	14	05014551	Bolt, 5/8"-11 X 2 1/2", G8, DH, Plain, 12'
3	12	05021383	Washer, 5/8", Lock, Zinc, 10'
	13	05021383	Washer, 5/8", Lock, Zinc, 11'
	14	05021383	Washer, 5/8", Lock, Zinc, 12'
4	12	05020270	Nut, 5/8"-11, G8, Hex, Zinc, 10'
	13	05020270	Nut, 5/8"-11, G8, Hex, Zinc, 11'
	14	05020270	Nut, 5/8"-11, G8, Hex, Zinc, 12'

49752
49753
49754

TRIP KIT, PLOW CT, HD, 2 SETS

ITEM	QTY	PART #	DESCRIPTION
1	2	00011999	Spring, Compression Trip Assembly, HD <i>(See page 9)</i>
		00040163	Spring, Compression Trip Assembly <i>(See page 9)</i>
2	4	05022051	Pin, 1" X 3/4", Flat, HD
3	4	05021202	Bushing, 1 1/2" X 1" X 10" GA, Zinc
4	4	05022026	Pin, 1/4" X 2", Roll, Zinc

50478
50477

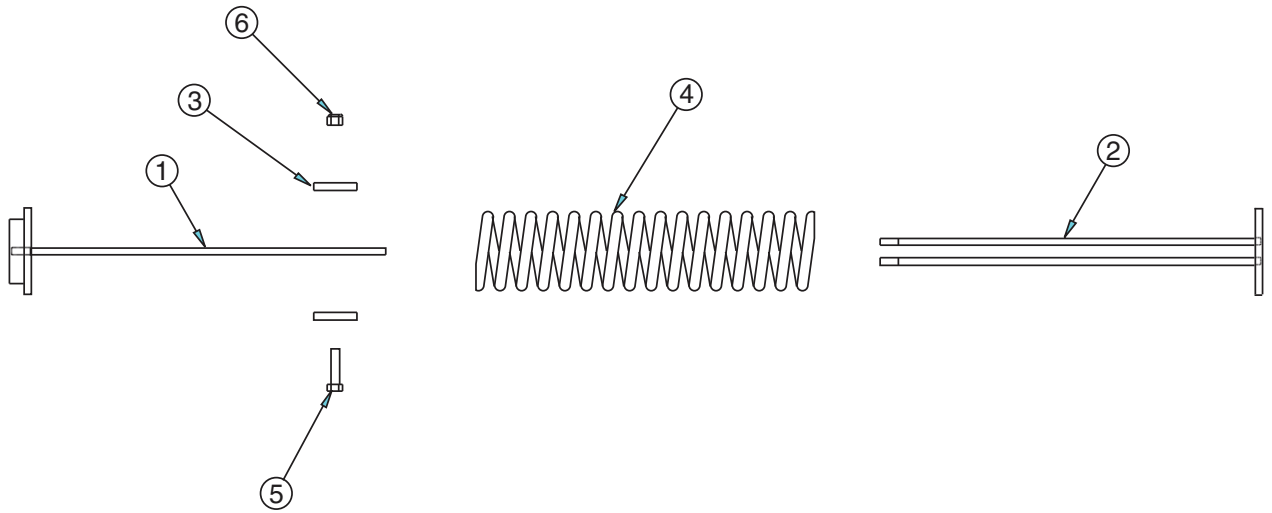

00011999 SPRING COMPRESSION TRIP ASSEMBLY, HVY
00040163 SPRING COMPRESSION TRIP ASSEMBLY, STD

ITEM	QTY	PART #	DESCRIPTION
1	1	00040164	Spring Bracket, Upper
2	1	00040165	Spring Bracket, Lower
3	2	00040167	Retainer
4	1	05035037	Spring, Compression, HVY
		05035007	Spring, Compression, STD.
5	1	05010741	Bolt $\frac{5}{8}$ -11 X 2 $\frac{1}{2}$ ", HHCS, G8, Zinc
6	1	05020837	Nut, $\frac{5}{8}$ -11, GC, Toplock, C&W

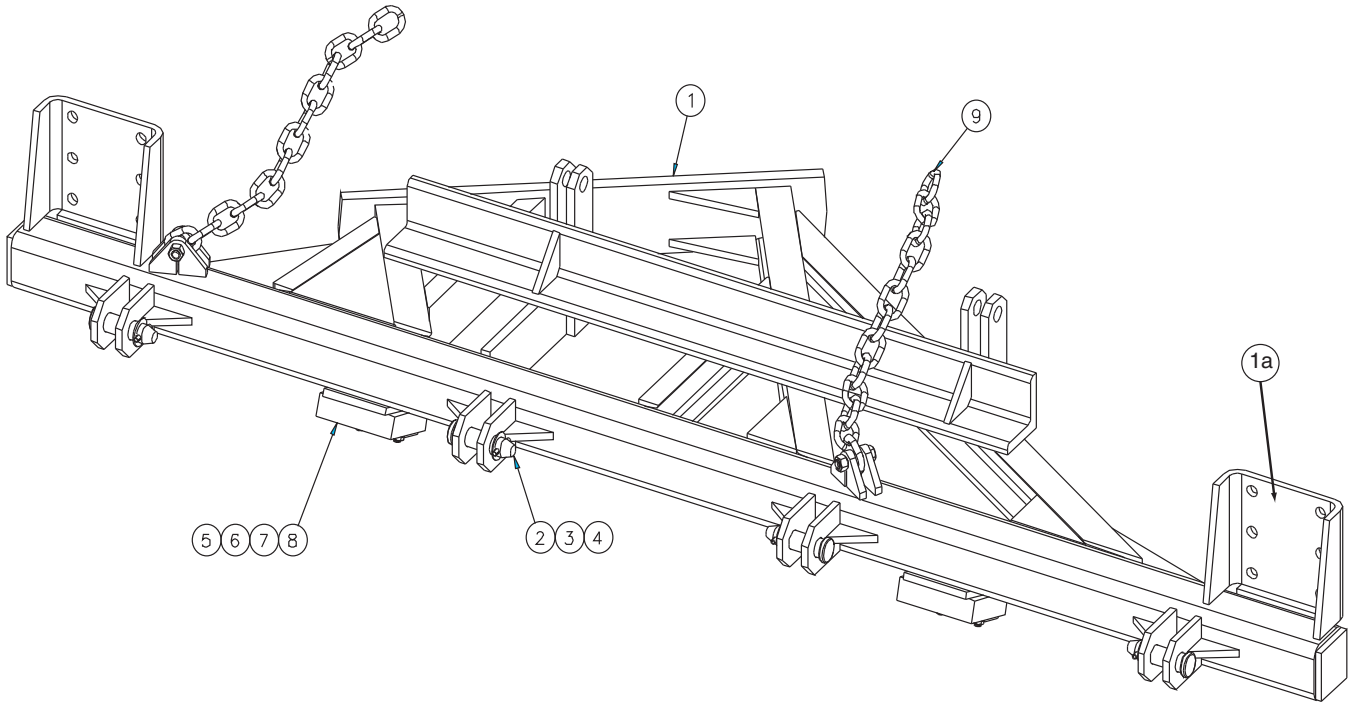

PUSHFRAME KIT, FA, CT, 10'-12'

ITEM	QTY	PART #	DESCRIPTION
1	1	00027826	Pushframe Weldment, FA, CT, 10'-12'
		1a. 00094823	Mount Pad (Qty. 1)
2	4	05022067	Pin, 1¼" DIA X 4½" OA, Flat Head
3	4	05022039	Pin, ⅝" X 2", Roll
4	4	05021191	Bushing, 1⅞" X 1¼" X 14 GA, Zinc
5	2	05051480	Bumper, Plow, 1½" X 5" X 6", Rubber
6	2	00020722	Bumper Retainer, Pushframe, STD
7	4	05010697	Bolt, ½-13 X 3", G8, HHCS, Zinc
8	4	05020847	Nut, ½-13, GC, Toplock, C&W
9	2	00027691	Chain, ½ x 60.0
10	2	05010741	Bolt, ⅝-11 x 2½, G8, HHCS, Zinc
11	2	05020837	Nut, ⅝-11, GC, Top Lock, C&W

50991

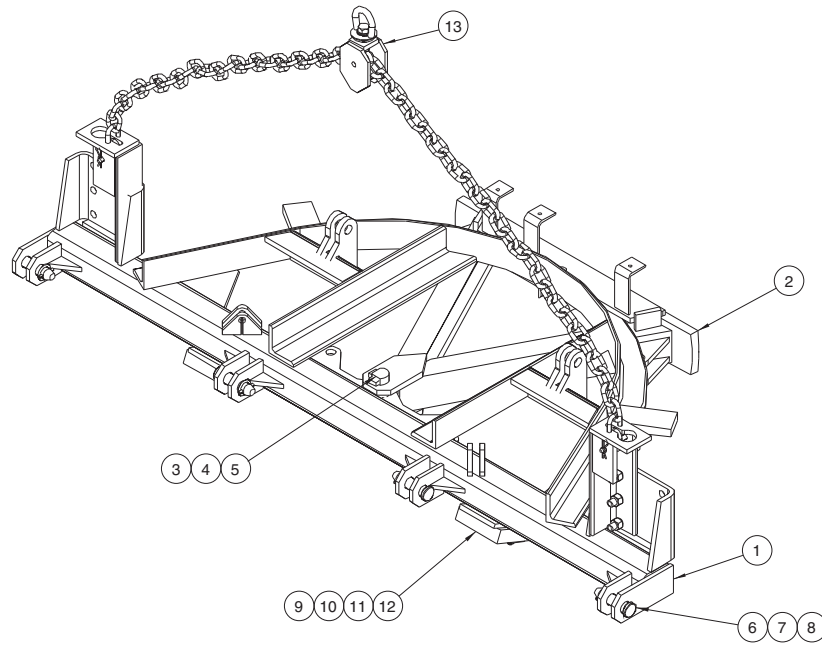

PUSHFRAME KIT, REV, CT, 10'-12', 1 CHAIN LIFT

ITEM	QTY	PART #	DESCRIPTION
1	1	00055949	Pushframe Weldment, Reversing, 10'-12'
2	1	00027881	A-Frame Weldment
3	1	05022047	Pin, 1¼ x 7¼, Flat, Head
4	1	05022044	Pin, 5/16 x 3, Roll
5	1	05011316	Washer, 1¼, Flat, Zinc
6	4	05022067	Pin, 1¼ DIA x 4 1/2 Flat, HEad
7	4	05022039	Pin, 5/16 x 2, Roll
8	4	05021191	Bushing, 1.88 x 1¼ x 14 Gauge, Zinc
9	2	05051480	Bumper, Plow, 1½ x 5 x 6, Rubber
10	2	00020722	Bumper Retainer, Pushframe
11	4	05010697	Bolt, ½ x 13 x 3, G8, HHCS, Zinc
12	4	05020847	Nut, ½ - 13, GC, Top Lock, C&W
13	1	00031154	Chain Lift Kit, Swivel Loop (See page 12 for breakdown)

55941

Hydraulic Diagram for the Reversing Cylinders

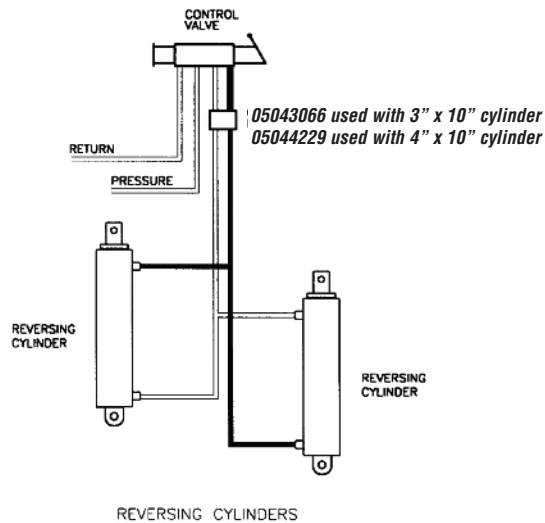

Hydraulic Diagram for the Single Reversing Cylinder

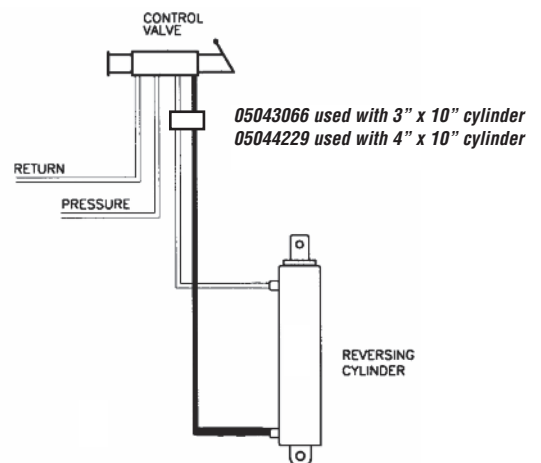

CHAIN LIFT KIT, SWIVEL LOOP

ITEM	QTY	PART #	DESCRIPTION
1	1	00043173	Swivel Loop, Chain
2	1	00036995	Bracket Weldment, RH, Chain
3	1	00036996	Bracket Weldment, LH, Chain
4	1	00043175	Chain, ½ x 120
5	3	05022136	Pin, ½ x 4½, 4" Grip Bent
6	6	05010765	Bolt, ¾-10 x 2¼, G8, HHCS, Zinc
7	6	05020271	Nut, ¾-10, G8, Hex, Zinc
8	1	05022040	Pin, 1 x 4.25 No Head
9	2	05021202	Bushing, 1.5 x 1 x 10GA, Zinc
10	1	05022002	Pin, #8 Hair
11	1	05022026	Pin, .250 x 2, Roll, Zinc

31154

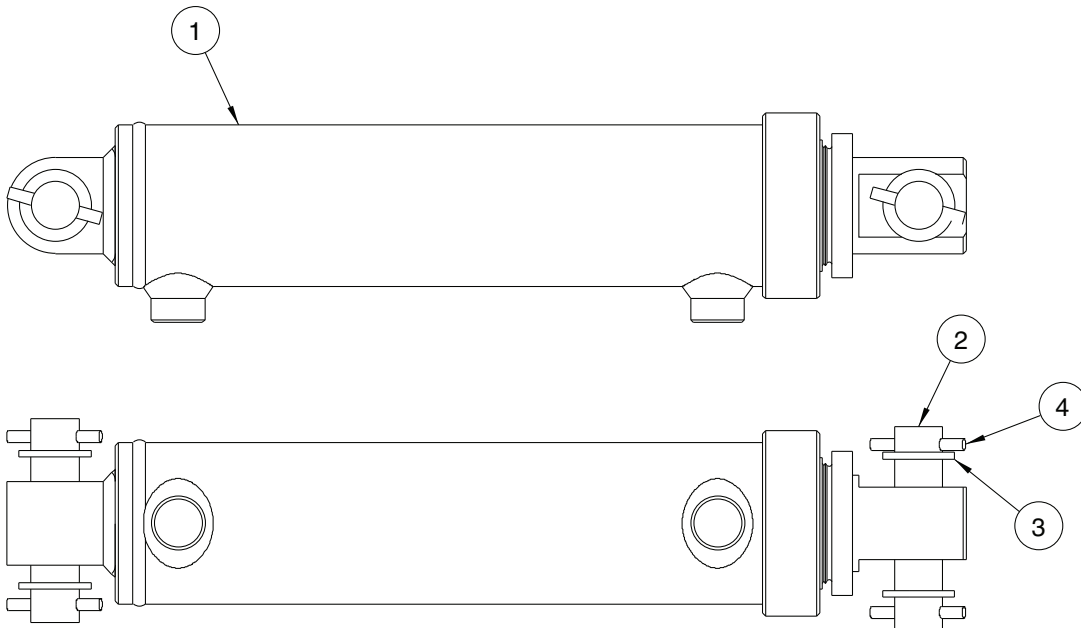

REVERSING KIT, PLOW, 3X10, WITH MOUNTING HARDWARE

ITEM	QTY	PART #	DESCRIPTION
1	2	05000000	Cylinder, 3" x 10" DA (See page 29 for breakdown)
2	4	05022040	Pin, 1" x 4¼", No Head
3	8	05021202	Bushing, 1½" x 1" x 10 Gauge, Zinc
4	8	05022026	Pin, ¼" x 2", Roll, Zinc
5	1	05043067	Cushion Block Assembly, w/ Hose (Not Shown)
6	1	05037080	Hose Assembly, Plow, w/R608 (Not Shown)
7	3	00055000	Clip, Hose Hold Down
8	3	05010620	Bolt, ⅝-18 x 1½, G8, HHCS, Zinc
9	3	05020909	Nut, ⅝-18, GC, Top Lock, C&W
10	6	05050608	Cable, Tie, HD, 14" x 3" W, Black

50926

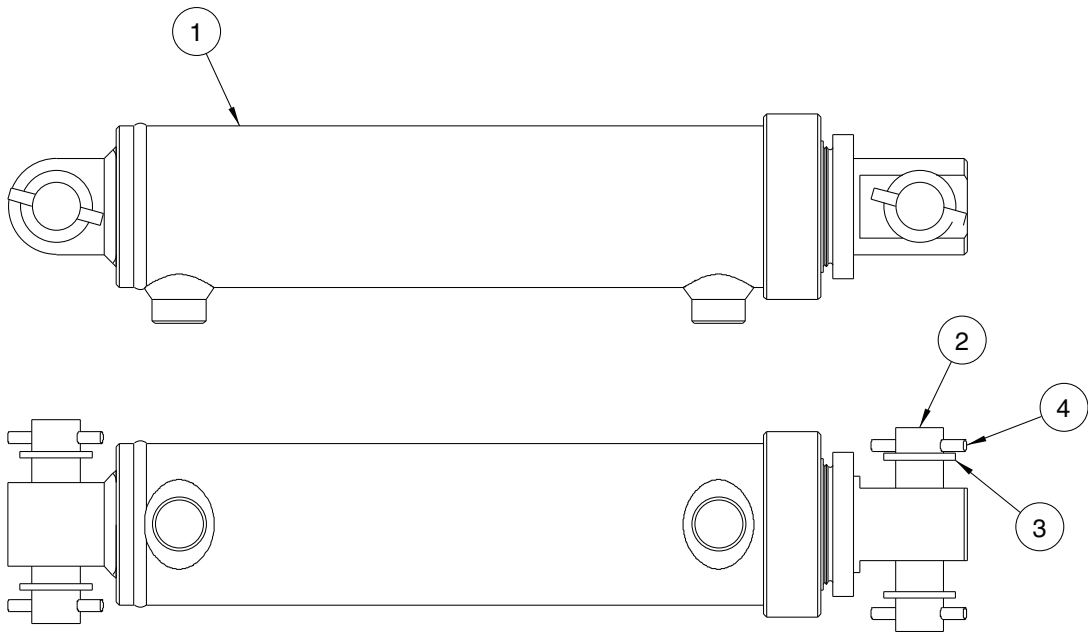

REVERSING KIT, PLOW, 4X10, WITH MOUNTING HARDWARE

ITEM	QTY	PART #	DESCRIPTION
1	2	05002640	Cylinder, 4" x 10" DA (See page 30 for breakdown)
2	4	05022040	Pin, 1" x 4/4", No Head
3	8	05021202	Bushing, 1 1/2" x 1" x 10 Gauge, Zinc
4	8	05022026	Pin, 1/4" x 2", Roll, Zinc
5	1	05044230	Hose Kit, Cushion Block @ 1000 PSI (Not Shown)
6	1	05037080	Hose Assembly, Plow, w/R608 (Not Shown)
7	3	00055000	Clip, Hose Hold Down
8	3	05010620	Bolt, 5/16"-18 x 1 1/2, G8, HHCS, Zinc
9	3	05020909	Nut, 5/16"-18, GC, Top Lock, C&W
10	6	05050608	Cable, Tie, HD, 14" x 3" W, Black

50953



05051507

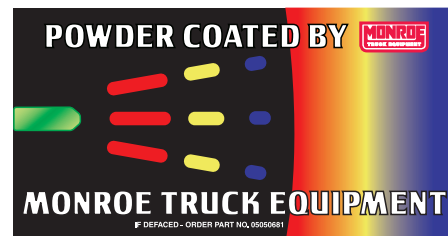

05050681

DECAL KIT, PLOW

ITEM	QTY	PART #	DESCRIPTION
1	1	05051507	Decal: Monroe Snowplow
2	1	05050681	Decal: Bonded Powder

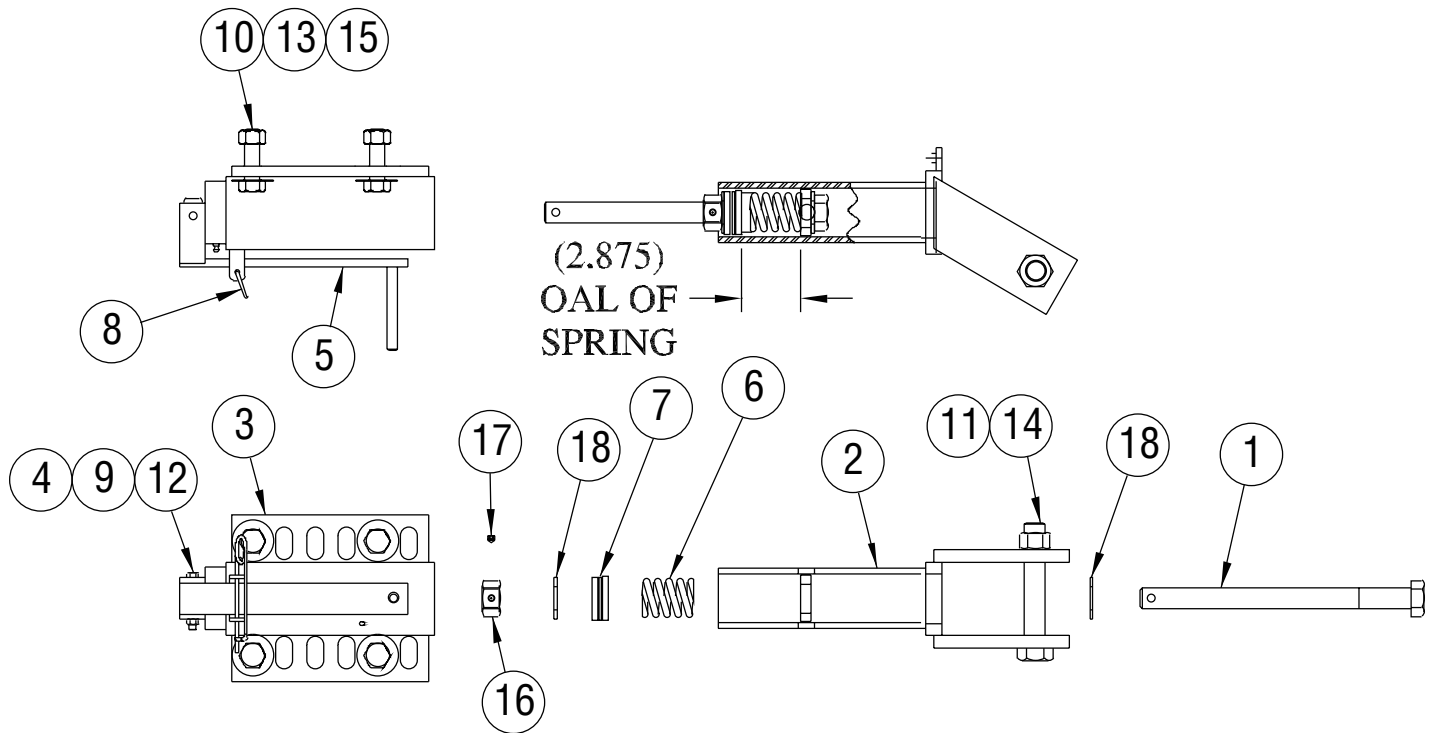

00051200 JACK ASSEMBLY, SCREW, ROUND

Item	Qty.	Part Number	Description
1	1	00051204	ADJUSTMENT SCREW
2	1	00051202	INNER TUBE WELDMENT
3	1	00051201	OUTER TUBE WELDMENT
4	1	00010000	NUT, ADJUSTMENT SCREW
5	1	00051203	ADJUSTMENT HANDLE WELDMENT
6	1	05035000	SPRING, COMPRESSION
7	1	05030000	BEARING THRUST
8	1	05022074	PIN, SAFETY, .120 DIA X 4.375 LG
9	1	05010624	BOLT, .3125-18 X 2.5, G8, HHCS, ZINC
10	4	05010766	BOLT, .75-10 X 2.5, G8, HHCS, ZINC
11	1	05010822	BOLT, 1-8 X 6, G8, HHCS, ZINC
12	1	05020909	NUT, .3125 -18, GC, TOP LOCK, C&W
13	4	05020849	NUT, .75-10, GC, TOP LOCK, C&W
14	1	05020834	NUT, 1-8, GC, TOP LOCK, C&W
15	8	05021063	WASHER, .75, STRUCTURAL, FLAT, ZINC
16	1	00121661	NUT, RETAINER, ADJ, SCREW
17	1	05017137	SCREW, .313-18 X .375", SSS, CP, ZC
18	2	05021020	WASHER, 1" FLAT, MIL-CARB, SAE ZC

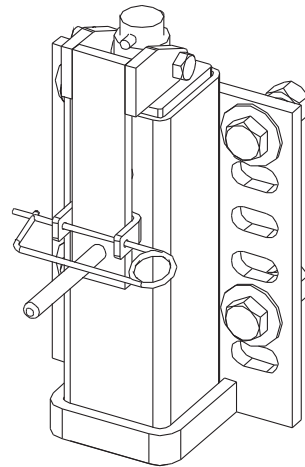
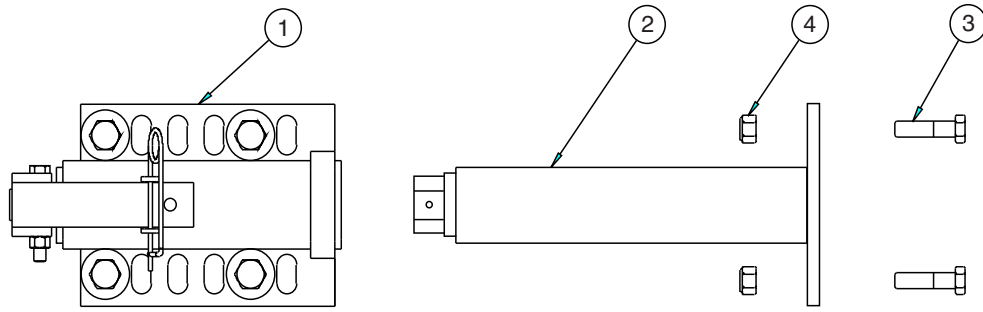

00051035 MUSHROOM SHOE JACK PARTS LIST

ITEM	QTY	PART #	DESCRIPTION
1	1	00041967	Jack Assembly, Outer Tube, Square (See page 16)
2	1	00051036	Assembly, Inner Tube
3	2	05010741	Bolt, $\frac{5}{8}$ " - 11" x 2 $\frac{1}{2}$ ", G8, Zinc
4	2	05020837	Nut, $\frac{5}{8}$ " - 11", GC, Top Lock, C&W
5	2	05051009	Shoe, Mushroom, Tapered, 11 $\frac{1}{2}$ " x 8"
	2	05050120	Shoe, Mushroom, 10 $\frac{1}{4}$ " Carbide
6	1	05050288	Grease Zerk, $\frac{1}{4}$ " - 28", Straight

Items 1-4 are included in the Jack Assembly, Mushroom Shoe Jack and can be ordered using the part number 00051035.

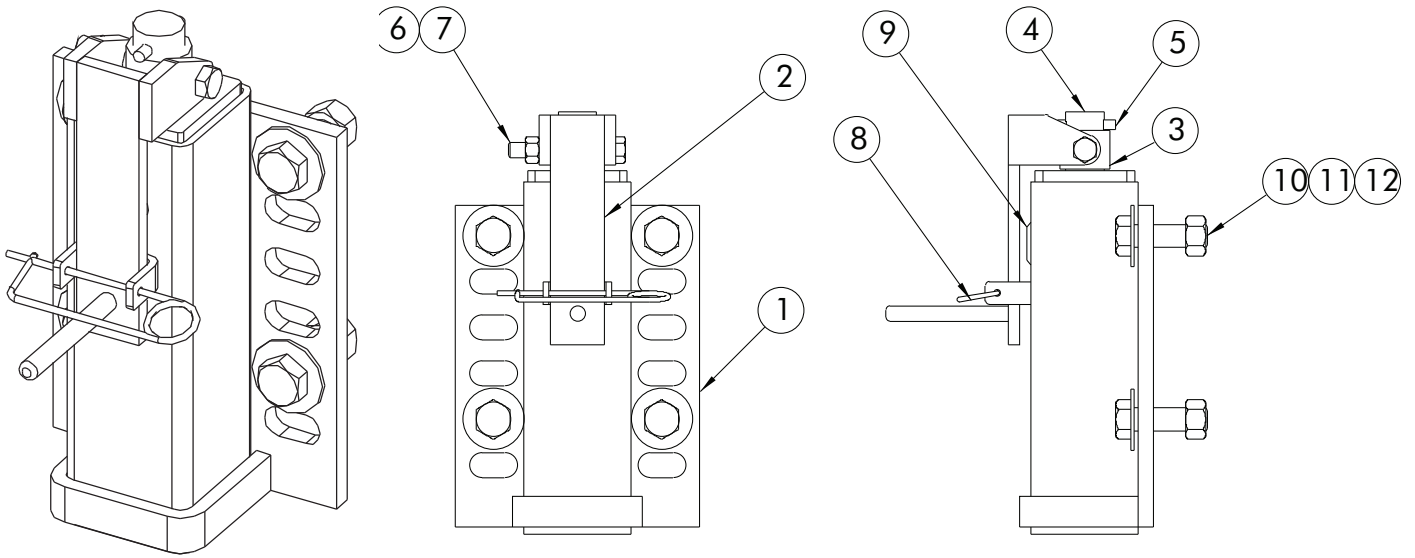

00041967 JACK ASSEMBLY PARTS LIST

ITEM	QTY	PART #	DESCRIPTION
1	1	00051027	Assembly, Outer Tube
2	1	00051020	Assembly, Handle Crank
3	1	00051022	Pipe, Collar, Crank
4	1	00051021	Assembly, Rod, Acme Threaded, Crank
5	1	05022039	Pin, Roll, $\frac{5}{16}$ x2
6	1	05010699	Bolt, $\frac{1}{2}$ -13x3 $\frac{1}{2}$, G8, HHCS, Zinc
7	1	05020847	Nut,x13, GC, Top Lock, C&W
8	1	05022074	Pin Safety, .120 DIA x 4 $\frac{3}{4}$ LG
9	1	05050023	Cap Grease, Plastic, 1 $\frac{1}{16}$ DIA
10	4	05010766	Bolt, $\frac{3}{4}$ -10x2 $\frac{1}{2}$, G8, HHCS, Zinc
11	8	05021063	Washer, $\frac{3}{4}$, Flat, Structural, Zinc
12	4	05020849	Nut, $\frac{3}{4}$ -10. GC, Top Lock, C&W

**00058146 INNER TUBE WELDMENT, CASTER/SKID
OLD STYLE SQUARE**

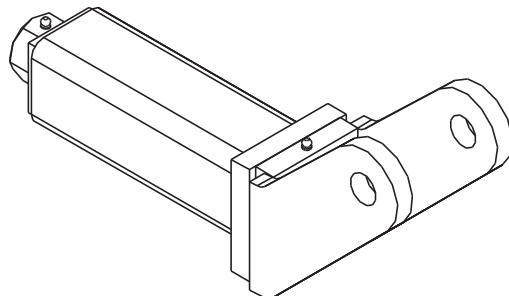

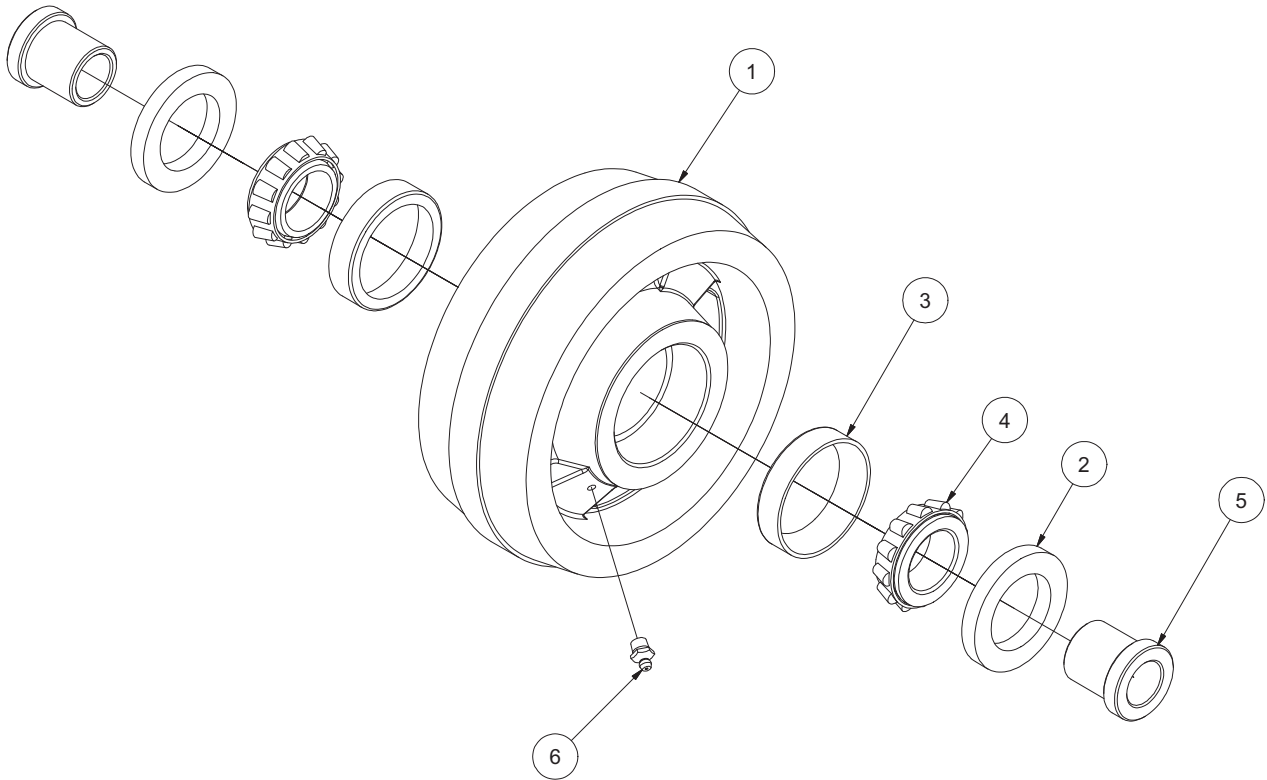

00011653 CASTER WHEEL PARTS LIST

ITEM	QTY	PART #	DESCRIPTION
1	1	05051398	WHEEL, CAST, 3 X 8
2	2	05053363	SEAL, BEARING, 1.75 X 2.718
3	2	05030015	RACE, KOYO, F/14137A BEARING
4	2	05030014	BEARING, TAPERED, INNER RACE
5	2	05051326	BUSHING, CASTER, 3 X 8
6	1	05050003	GREASE ZERK, .125 NPT STRAIGHT

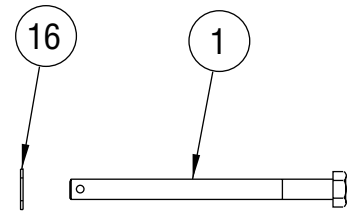
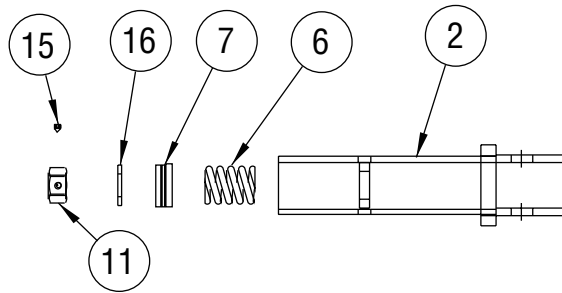
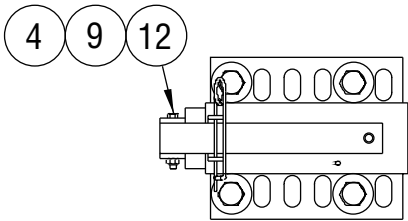
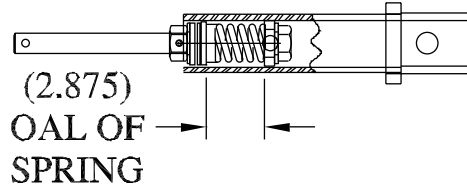
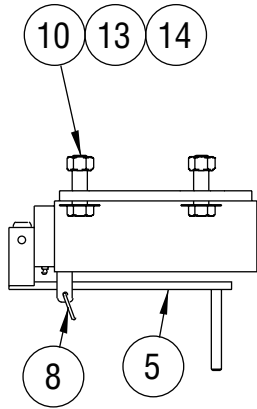

00054906 JACK ASSEMBLY, PLOW, SCREW, ROUND

ITEM	QTY	PART #	DESCRIPTION
1	1	00051204	Adjustment Screw
2	1	00099360	Jack Weldment, Inner Tube, Round
3	1	00051201	Outer Tube Weldment
4	1	00010000	Nut, Adjustment Screw
5	1	00051203	Handle Weldment
6	1	05035000	Spring, Compression, 2.13 OD
7	1	05030000	Bearing, Thrust, 1" ID
8	1	05022074	Pin Safety .120 DIA x 4% Long
9	1	05010624	Bolt, 5/16-18 x 2 1/2, G8, HHCS, Zinc
10	4	05010766	Bolt, 3/4-10 x 2 1/2, G8, HHCS, Zinc
11	1	00121661	Nut, Retainer, Adj. Screw, Plow Jack
12	1	05020909	Nut, 5/16-18, GC, Top Lock, C&W
13	4	05020849	Nut, 3/4-10, GC, Top Lock, C&W
14	4	05021063	Washer, 3/4, Structural Flat, Zinc
15	1	05017137	Screw, .313-18 x .375 SSS
16	2	05021020	Washer, 1, Flat, Mil-Carb, SAE, Zinc

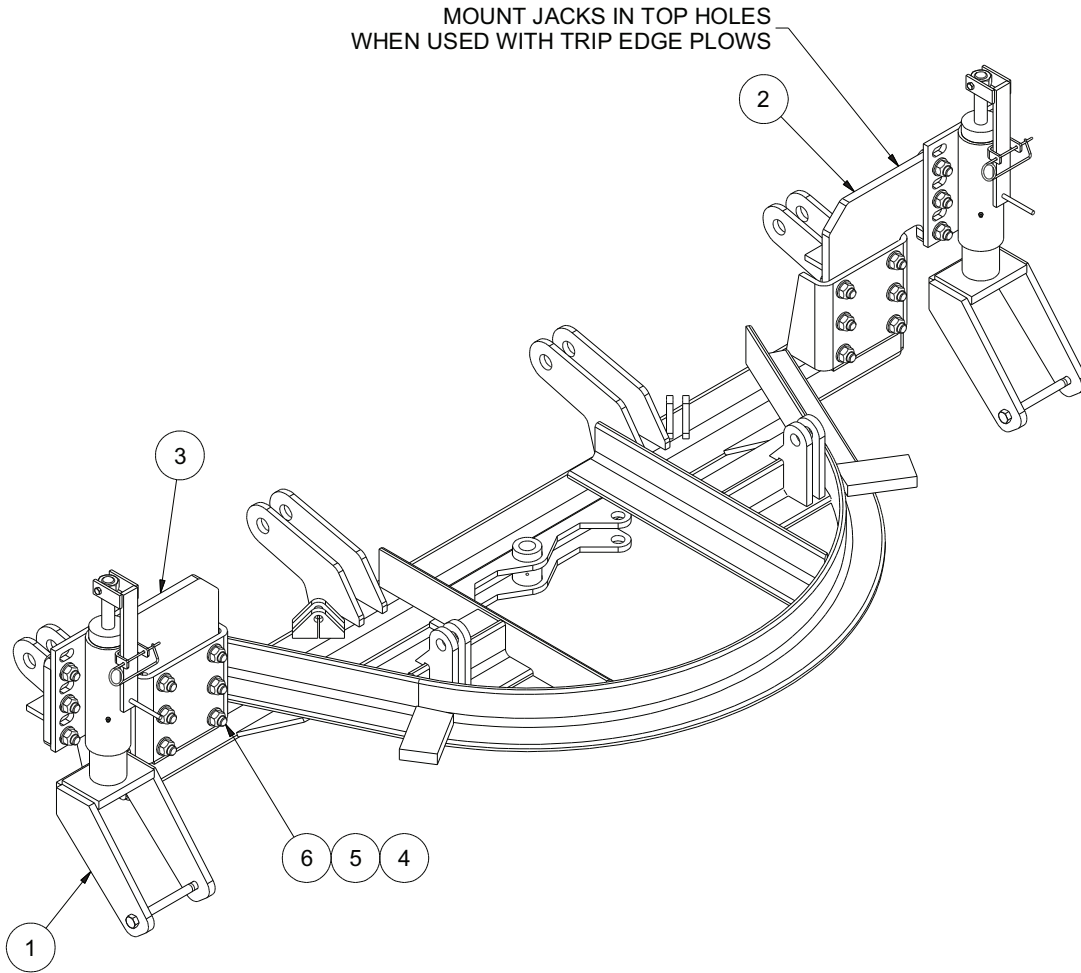

00106638 JACK KIT, PLOW, PNEU TIRE, 16.0 FOAM FILLED, ROUND SCREW STYLE

ITEM	QTY	PART #	DESCRIPTION
1	2	00106639	Jack Assembly, Plow, Screw Round (<i>See page 22</i>)
2	1	00106280	Extension Weldment, Mount, RH
3	1	00106281	Extension Weldment, Mount, LH
4	48	05021063	Washer, .750 Structural, Flat, Zinc
5	24	05020849	Nut, .750-10, GC, Top Lock, C&W
6	24	05010766	Bolt, .750-10 x 2.50, G8, HHCS, Zinc
7	2	05051084	Wheel Assembly, Pneu, Foam Fill (Not Shown)

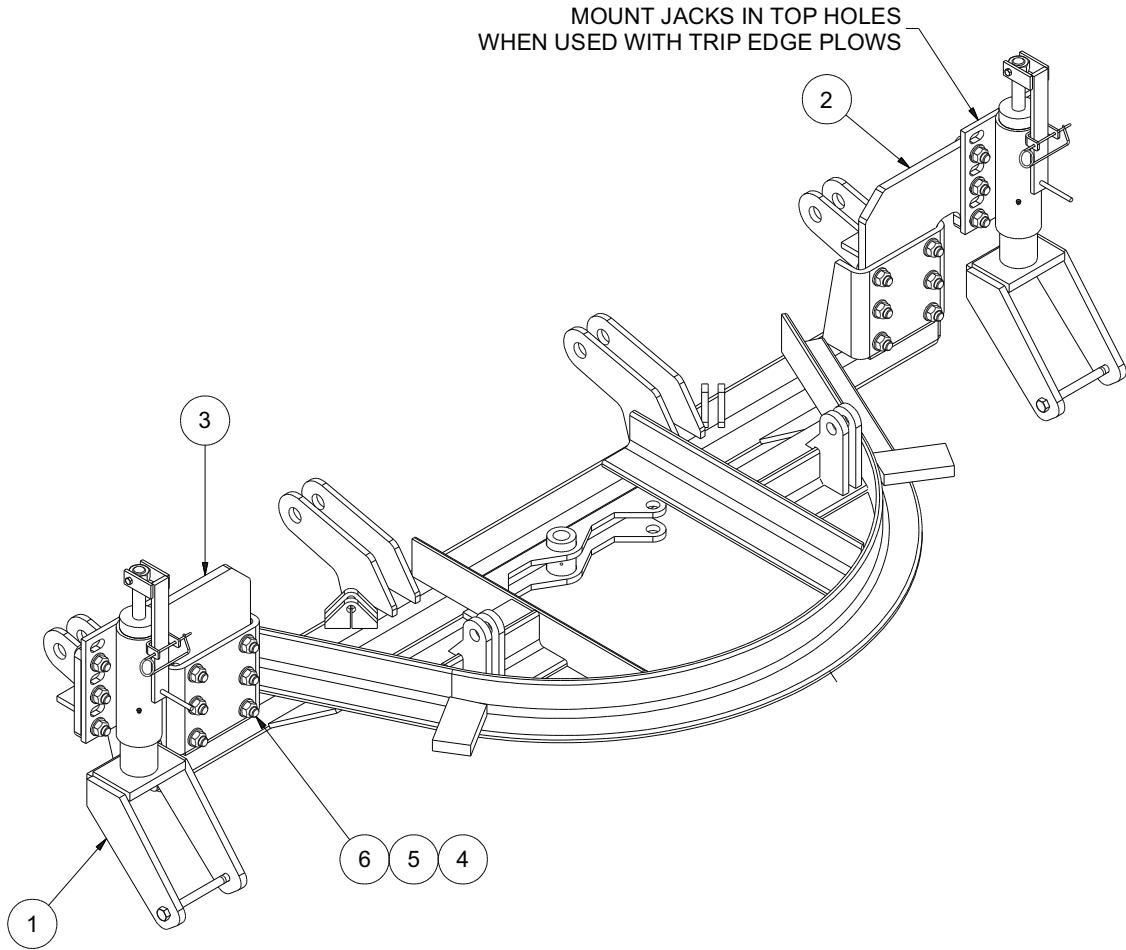

00106637 JACK KIT, PLOW, PNEU TIRE, 16.0, ROUND SCREW STYLE

ITEM	QTY	PART #	DESCRIPTION
1	2	00106639	Jack Assembly, Plow, Screw Round (See page 22)
2	1	00106280	Extension Weldment, Mount, RH
3	1	00106281	Extension Weldment, Mount, LH
4	48	05021063	Washer, .750 Structural, Flat, Zinc
5	24	05020849	Nut, .750-10, GC, Top Lock, C&W
6	24	05010766	Bolt, .750-10 x 2.50, G8, HHCS, Zinc
7	2	00011654	Wheel Assembly, Pneu (Not Shown) (See page 23)

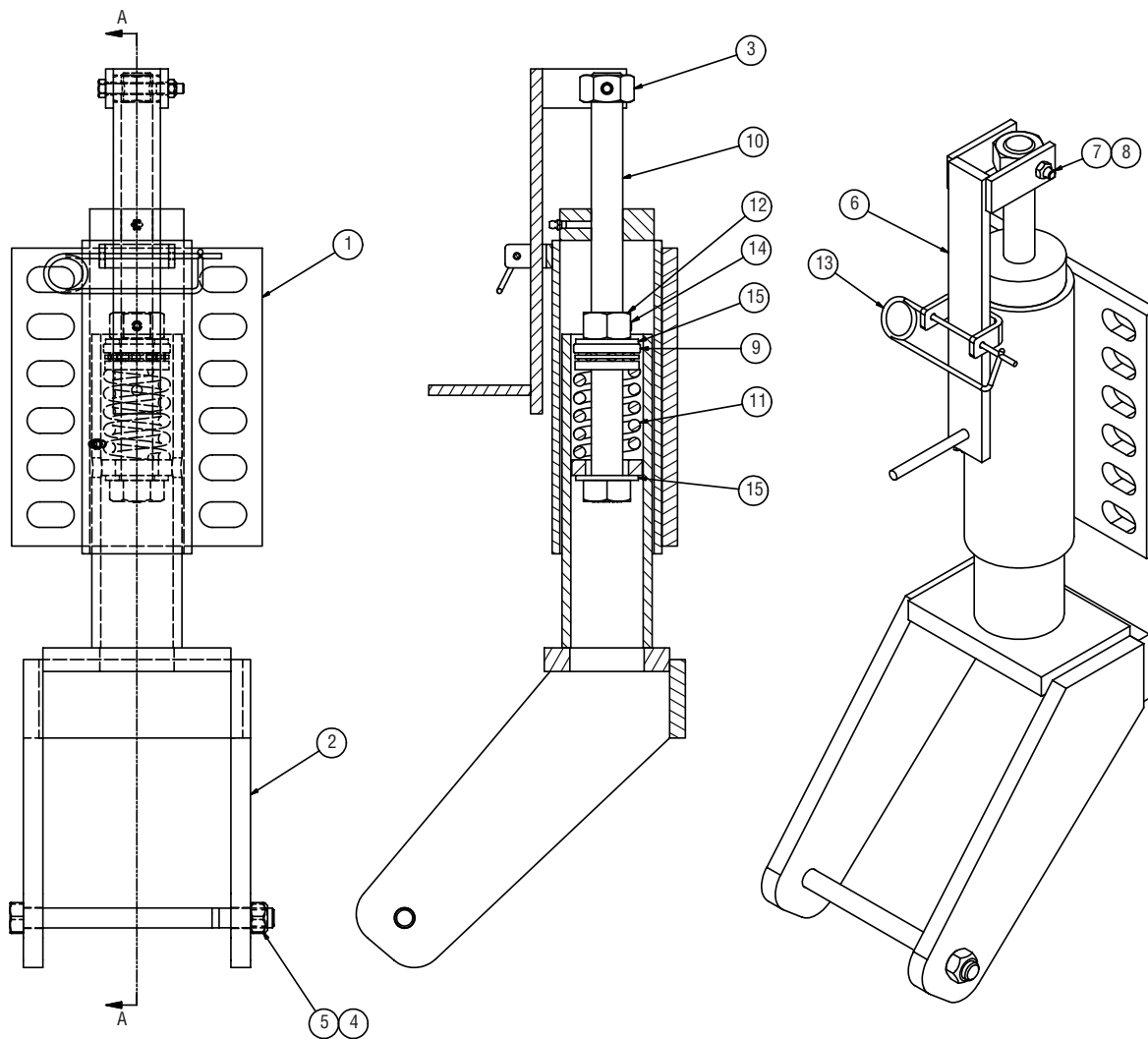

00106639 JACK ASSEMBLY, PLOW, SCREW, ROUND PNEUMATIC WHEEL

ITEM	QTY	PART #	DESCRIPTION
1	1	00051201	Jack Weldment, Plow, Outer Round
2	1	00106640	Yoke Weldment, Jack, Plow
3	1	00010000	Nut, Adjustment, Jack Plow
4	1	05010755	Bolt, .625-11 x 8, G8, HHCS, Zinc
5	1	05020837	Nut, .625-11, GC, Top Lock, C&W
6	1	00051203	Handle Weldment, Adj, Plow Jack
7	1	05010624	Bolt, .313-18 x 2.50, G8, HHCS, Zinc
8	1	05020909	Nut, .313-18, GC, Top Lock, C&W
9	1	05030000	Bearing, Thrust, 1" ID
10	1	00051204	Adjustment Screw
11	1	05035000	Spring, Compression, 2.13" OD, 2.875" OAL
12	1	00121661	Nut, Retainer, Adj Screw
13	1	05022074	Pin, .120 x 4.375 Safety
14	1	05017137	Screw, .313-18 x .375 SSS CP Zinc
15	2	05021020	Washer, 1.0 Flat, Mil-Carb, SAE

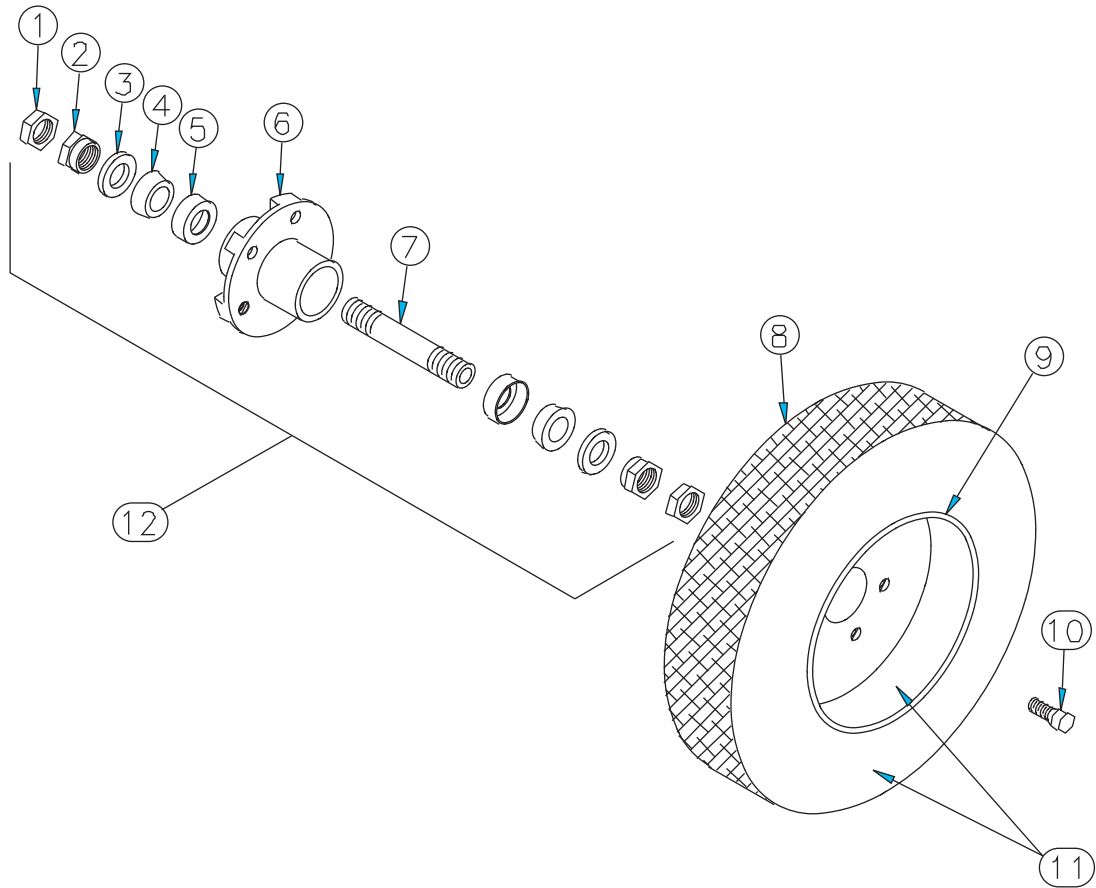

00011654 WHEEL ASSEMBLY, PNEUMATIC

ITEM	QTY	PART #	DESCRIPTION
1	2	---	Jam, Nut, 1"-14"
2	2	---	Nut, 1"-14"
3	2	05051176	Seal, Wheel
4	2	05030013	Bearing
5	2	05030017	Cup
6	1	05051323	Hub
7	1	05051439	Spindle
8	1	05051204	Tire
9	1	05050539	Rim
10	5	05016985	Bolt
11	1	05051084	Foam Filled Tire and Rim
12	1	05051083	Pneumatic Wheel Hub Assembly

****Items 1 & 2 are sold with Item 7.***

DEFLECTOR KIT, RUBBER

ITEM	QTY	PART #	DESCRIPTION
1	1	05050352	Belting, Rubber Snow, 10'
	1	05051423	Belting, Rubber Snow, 11'
	1	05051424	Belting, Rubber Snow, 12'
2	1	00020751	Strip, Backing, 10'
	1	00020752	Strip, Backing, 11'
	1	00020753	Strip, Backing, 12'
3	-----	05010620	Bolt, $\frac{5}{16}$ "-18x1 $\frac{1}{2}$ ", G8, HHCS, Zinc
4	-----	05020606	Nut, $\frac{5}{16}$ "-18, G2, Spinlock, Zinc

43103
43104
43105

** Quantity of 13 Bolts and Nuts are needed for the 10' deflector.
Quantity of 15 Bolts and Nuts are needed for the 11' & 12' deflector.

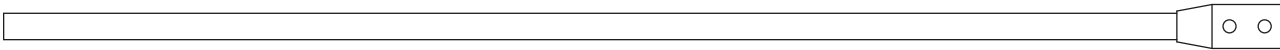

MARKERS, FLEXIBLE PLASTIC

ITEM	QTY	PART #	DESCRIPTION
1	1 Pair	05051432	Markers, 36" Fluorescent Orange Flexible Markers
2	1 Pair	05051181	Markers, Cable, 42" L, Straight, Yellow w/ Red Day Glo Tip

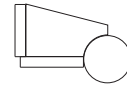

SHOE KIT,SKID, MOLDBOARD



ITEM	QTY	PART #	DESCRIPTION
1	2	05050221	Shoe, Moldboard, Cast, 8", 10°
2	4	05014560	Bolt, 5/8" - 11 x 5", G8, Dome Head, Plain
3	4	05021383	Washer, 5/8", Lock, Heavy, Zinc
4	4	05020270	Nut, 5/8" - 11, G8, Hex, Zinc



61797



SHOE KIT, SKID, PLOW, MOLDBOARD

ITEM	QTY	PART #	DESCRIPTION
1	2	00010271	Shoe Assembly, Moldboard
2	4	05014553	Bolt, 5/8"-11 x 3", G8, DH, Plain
3	4	05010739	Bolt, 5/8"-11 x 2", G8, HHCS, Zinc
4	8	05021383	Washer, 5/8", Lock, Zinc
5	8	05020270	Nut, 5/8"-11, G8, Hex, Zinc

59115

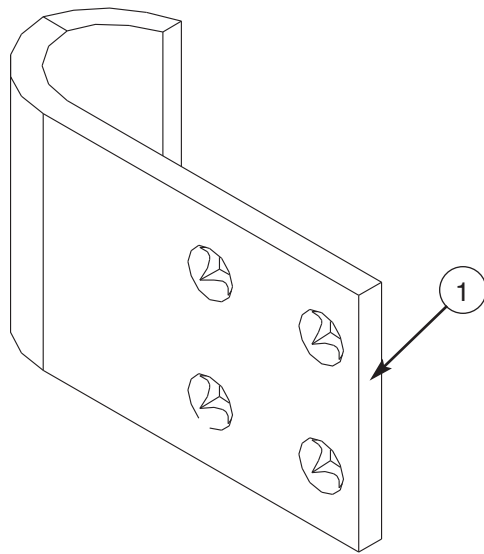

CURB GUARD, WRAP-AROUND

ITEM	QTY	PART #	DESCRIPTION
1	1	05050000	Guard, Curb, $\frac{5}{8}$ x 6
2	2	05014555	Bolt, $\frac{5}{8}$ -11 x 3 $\frac{1}{2}$ ", G8, Dome Head, Plain

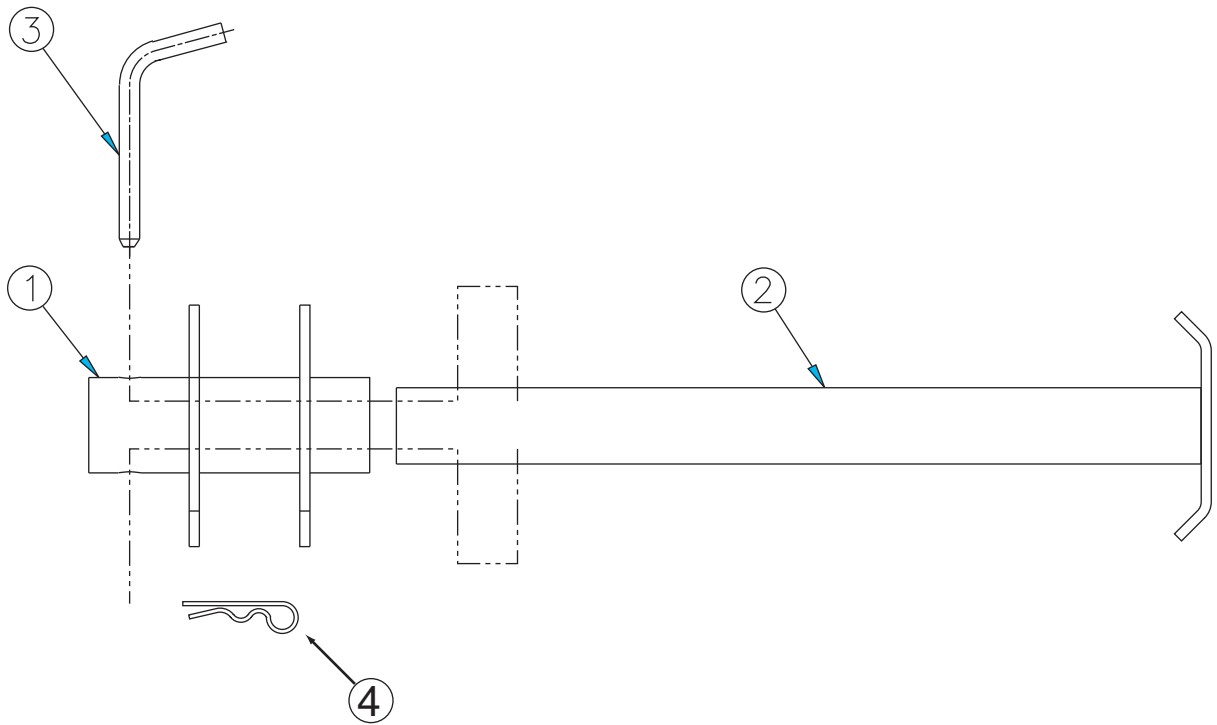

JACK KIT, PARKING JACK, A-FRAME PARKING JACK

ITEM	QTY	PART #	DESCRIPTION
1	1	00010265	Tube Jack Weldment, Outer, Parking
2	1	00010267	Inner Tube Assembly
3	1	05022136	Pin, 1/2" x 4 1/2", 4" Grip Bent, Zinc (Includes Item 4)
4	1	05022035	Pin, #11, Hair, Zinc

10264

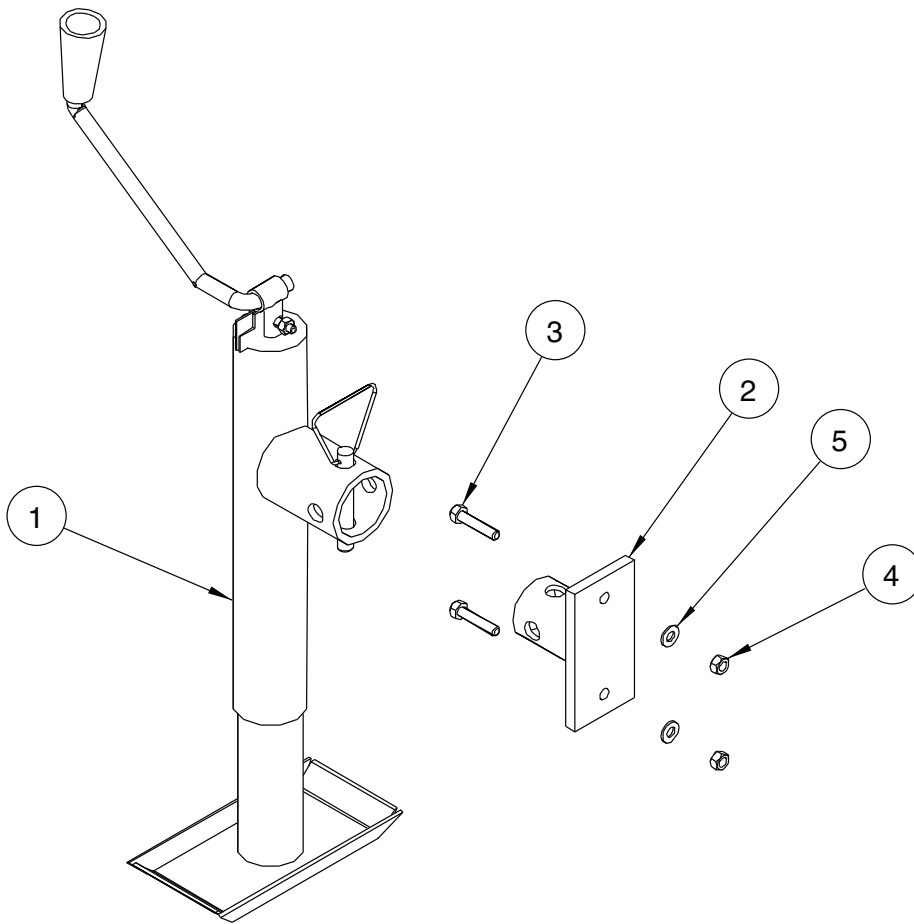

JACK KIT, PARKING, TOP WING, TUBE MOUNT, REMOVABLE

ITEM	QTY	PART #	DESCRIPTION
1	1	05050227	Jack Assembly, Top Wind, Tube Mount
2	2	00084491	Mount Weldment, Jack Top Wind
3	4	05010620	Bolt, $\frac{5}{16}$ -18 x $1\frac{1}{2}$, G8, HHCS, Zinc
4	4	05020909	Nut, $\frac{5}{16}$ -18, GC, Top Lock, C&W
5	4	05021306	Washer, $\frac{5}{16}$, Flat, Zinc

61212

05000000 CYLINDER, 3 X 10, DA, NITRIDED ROD & POLY PAK

<i>BEST METAL</i>	ITEM	QTY	PART #	DESCRIPTION
	1	1	05000001	PACKING SET
	2	1	05000002	O-RING
	3	1	05000006	BOX
	4	1	05000007	NUT
	5	1	05000003	WIPER
	6	1	05000008	ROD
	7	1	05000014	TUBE
	8	1	05000010	PISTON
	9	1	05000004	O-RING
	10	2	05000005	CUP
	11	2	05000011	FOLLOWER
	12	1	05000012	NUT
	13	1	05000013	SEAL KIT

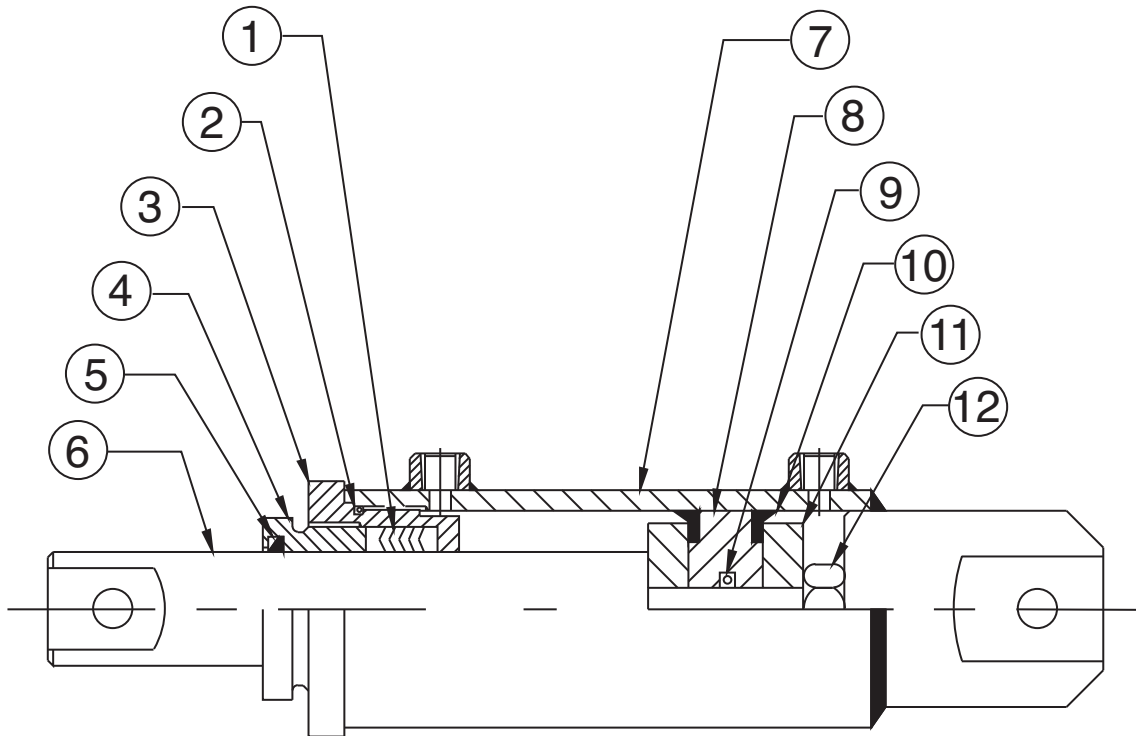

05002640 CYLINDER, 4 X 2 X 10 STROKE DA

DIREKT FORCE	PART #	DESCRIPTION
	---	BODY SUB-ASSEMBLY
	---	ROD
	---	GLAND
	05003366	PISTON
	05003240	HARDWARE KIT
	05003265	SEAL KIT

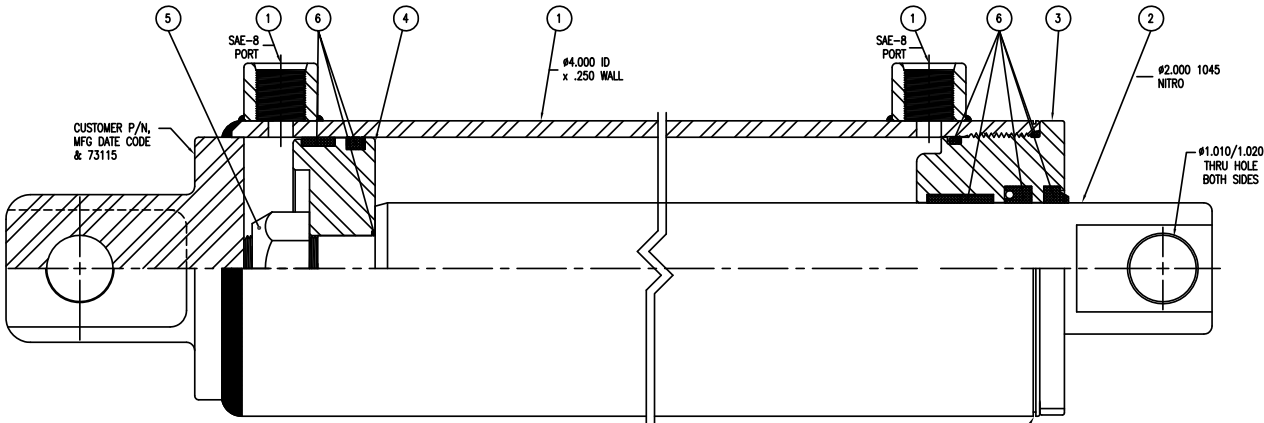

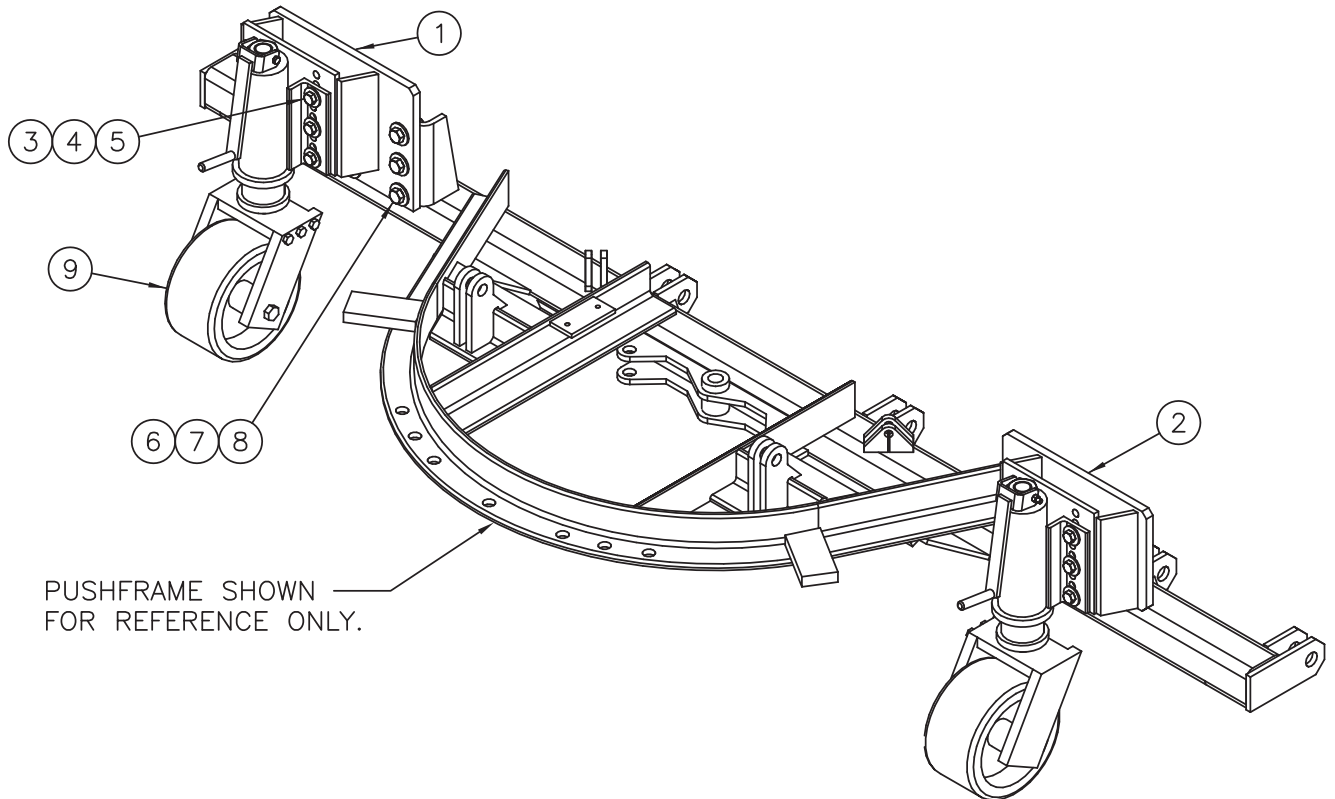

00149801 SNOW WHEEL KIT, RVS,4, 5, 6 ATCH 10'-12', W/ SNOW WHEEL			
ITEM	QTY	PART NUMBER	DESCRIPTION
1	1	00148093	EXT PL WLDMT,LH,SNOW WHEEL,
2	1	00148094	EXT PL WLDMT,RH,SNOW WHEEL,
3	12	05010739	BOLT .625-11 x 2.00 G8 HHCS ZC
4	12	05020837	NUT .625-11 GC TOPLOCK C&W
5	24	05021311	WASHER .625 FLAT ZC
6	12	05010766	BOLT .750-10 x 2.50 G8 HHCS ZC
7	12	05020849	NUT .750-10 GC TOPLOCK C&W
8	24	05021312	WASHER .750 FLAT ZC
9	2	05050762	WHEEL,SWIVEL W/ADJUSTER,6509

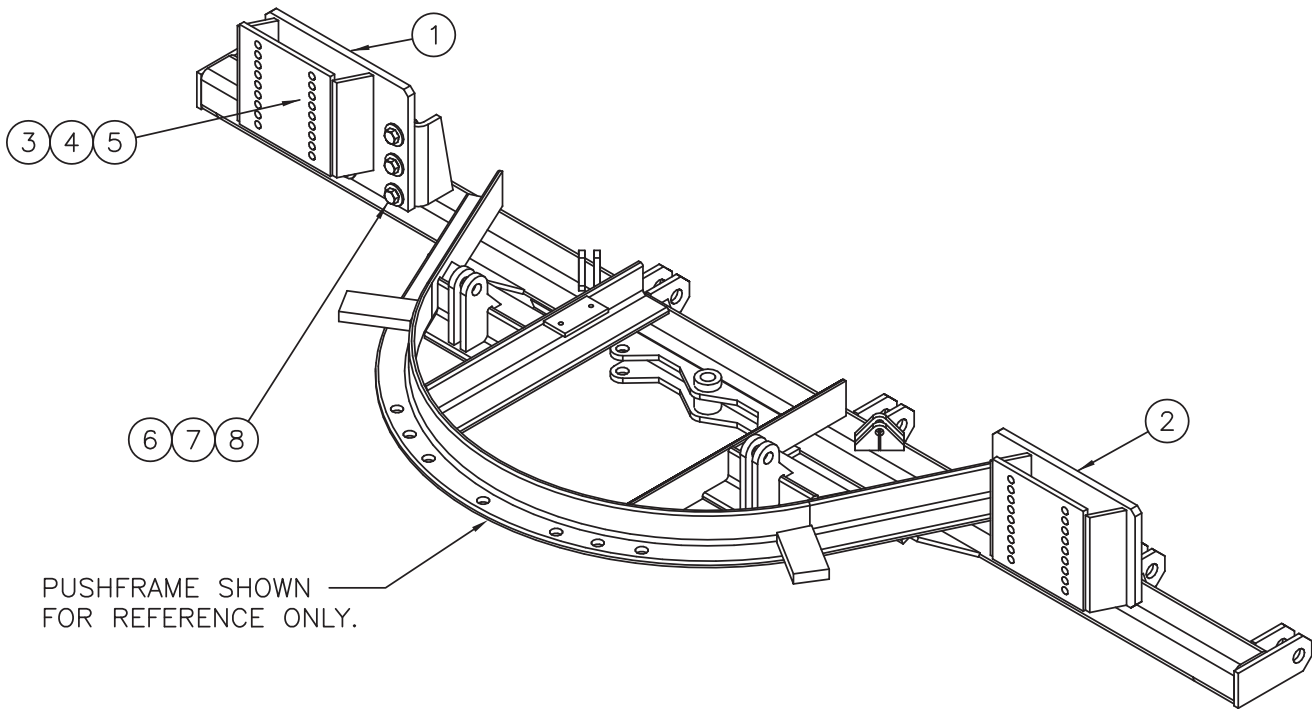

00148092 SNOW WHEEL KIT, RVS, 4, 5, 6 ATCH, 10'-12', W/O SNOW WHEELS

ITEM	QTY	PART NUMBER	DESCRIPTION
1	1	00148093	EXT PL WLDMT,LH,SNOW WHEEL,
2	1	00148094	EXT PL WLDMT,RH,SNOW WHEEL,
3	12	05010739	BOLT .625-11 x 2.00 G8 HHCS ZC
4	12	05020837	NUT .625-11 GC TOPLOCK C&W
5	24	05021311	WASHER .625 FLAT ZC
6	12	05010766	BOLT .750-10 x 2.50 G8 HHCS ZC
7	12	05020849	NUT .750-10 GC TOPLOCK C&W
8	24	05021312	WASHER .750 FLAT ZC

HOW TO ORDER PARTS

To order or inquire about replacement parts, please contact the **distributor** or **store** that the product was purchased through. To speed the information flow, please have the following information ready:

- Model Number
- Serial Number
- Part Number and/or description as per the parts manual
- Quantity needed

For further information about **Monroe Truck Equipment** replacement parts, please call 800-880-0109 and ask for **Snow & Ice Parts Sales**.

RETURN POLICY

Merchandise returned to **Monroe Truck Equipment** must have a Warranty Service Request (WSR) form filled out completely and signed by authorized personnel. To get your WSR form, call 800-880-0109. For whole goods ask for **Snow & Ice Sales**. For replacement parts, ask for **Snow & Ice Parts Sales**. All returned items are subject to a 15% restocking fee and must be sent freight prepaid!

MONROE TRUCK EQUIPMENT, INC. WARRANTY SNOW & ICE CONTROL PRODUCTS

Monroe Truck Equipment, Inc. warrants to the original purchaser, that if any part of the product proves to be defective in workmanship or material within **ONE YEAR** of the original installation, and is returned to us within 30 days of the discovered defect, we will (at our option) repair or replace the defective part. This warranty does not apply to damage resulting from misuse, neglect, accident, improper installation, normal wear items or lack of maintenance. This warranty is exclusive and supersedes all other warranties, whether expressed or implied. **Monroe Truck Equipment, Inc.** neither assumes, nor authorizes anyone to assume for it, any other obligation or liability in connection with this warranty and will not be liable for consequential damages.

All engines, pumps, motors, cylinders and valves are warranted by their manufacturer and not by **Monroe Truck Equipment, Inc.**. The manufacturer's warranty will apply to these parts. Electrical and hydraulic components are not to be disassembled without the express written permission of Monroe Truck Equipment. Use of replacement parts other than original equipment voids this warranty.

All defective parts returned must be accompanied by the model number, serial number, date installed, date of defect, description of defect, and the name of the distributor from whom it was purchased. All warranty claims must have prior written approval from **Monroe Truck Equipment, Inc.**

Please return the warranty registration card that accompanies this manual to confirm receipt of this parts catalog and acknowledge the information contained within. Failure to return the attached card may result in a voided warranty.



**1051 West 7th Street
 Monroe, WI 53566
 608-328-8127 ~ Fax: 608-328-4278**

Warranty Policy Uninstalled Parts and Equipment Provided by Monroe Truck Equipment

Monroe Truck Equipment will provide the following limited warranty for a period of one year to the original purchaser of all uninstalled goods provided by Monroe Truck Equipment:

LIMITED WARRANTY: All goods provided by Monroe Truck Equipment (MTE) will be free from defects in material and workmanship for a period of one year from the date of purchase by the original purchaser. This limited warranty shall be the sole and exclusive remedy for any such product found to be defective. This limited warranty supercedes all previous warranties and is exclusive and in lieu of all other warranties, whether expressed or implied.

This limited warranty applies only to parts or accessories manufactured by MTE and/or provided by same. Except with respect to title, this limited warranty does not pertain to parts or accessories not manufactured and/or provided by MTE, regardless of whether such parts or accessories were selected and/or recommended by MTE. MTE will, as a service to the buyer, pass on any warranties received from the original manufacturer of MTE provided parts and/or accessories.

MTE will not under any circumstances be liable for any incidental or consequential damages whether in tort, contract, or otherwise, for any bodily injury, death, property damage, loss of use, or loss of income resulting from or in any way arising out of any goods provided by MTE, or their sale, use, or manufacture.

Any warranty claim deemed to be arising from the result of misuse, abuse, neglect, accident, improper installation, lack of maintenance, act of war (whether declared or otherwise), or act of God will be denied. Any repair or modification by the buyer or any third party, without the prior written consent of MTE, will void any possible warranty compensation. Any damage deemed to be the result of abnormal operation will not be compensated by this warranty.

Normal or special maintenance items such as fuels, fluids, tires, belts, hoses, filters, air cleaners, light bulbs, and any other items subject to normal wear and tear that are supplied in connection with goods provided by MTE are not allowed under this warranty.

All engines, pumps, cylinders, valves, and motors are warranted by their manufacturer and not by Monroe Truck Equipment. The manufacturer's warranty will apply to these parts. Electrical and hydraulic components are not to be disassembled without the express written consent of MTE. Any disassembly of MTE provided components without prior authorization will void the applicable warranty.

Monroe Truck Equipment shall be the sole and final determining authority as it applies to the administration of this warranty policy. Purchaser acknowledges receipt of Monroe Truck Equipment Warranty Policy and agrees to be bound by same.



GLOBAL SOLUTIONS
 ARMORED VEHICLES ~ SPORT TRUCK CONVERSIONS
 MUNICIPAL SNOW & ICE CONTROL ~ FIRE APPARATUS
 PICKUP TRUCK ACCESSORIES ~ TRUCK EQUIPMENT/MODIFICATIONS



**1051 West 7th Street
Monroe, WI 53566
608-328-8127 ~ Fax: 608-328-4278**

Any and all warranty claims must be forwarded to MTE within 10 days of defect discovery. A copy of the original Monroe Truck Equipment invoice as well as the manufacturer's model number, serial number, and date of installation must accompany all correspondence regarding said claims. MTE will, at their option, choose whether to repair or replace the defective part unless otherwise specified by the original manufacturer of said part.

Procedures for Warranty Claims Notification

For submission of any warranty claim please contact Monroe Truck Equipment – Warranty Department at 800-356-8134

The following documentation will be needed when you call for initial warranty authorization:

1. A copy of the original MTE invoice.
2. Make, Model, and VIN or Serial Number of the equipment involved.
3. Part number and serial number of the part in question.
4. A complete description of the problem.

The following must accompany any claim submitted to Monroe Truck Equipment:

1. Documented photographs of any physical damage.
2. Inspection notes by MTE personnel or MTE authorized 3rd party.
3. Authorization number issued by Monroe Truck Equipment – Warranty Department.

Defective parts must be returned to Monroe Truck Equipment (freight prepaid) within 30 days of issuance of Authorization Number.

Monroe Truck Equipment reserves the right to void any warranty for failure to comply with Monroe Truck Equipment Warranty Policy.

This policy is effective October 11, 2012