



# LDS Pre-Wetting System

## Installation, Operation and Maintenance Manual

### Models

**LDS-333, 3.0 GPM**

**LDS-333-RS, 3.0 GPM Roll Spreader**

**LDS-1033, 10.4 GPM**



**Monroe Snow & Ice Control**

A Division of Monroe Truck Equipment

1051 W. 7th Street

Monroe, WI 53566

Phone: 608-328-8127

Fax: 608-329-8488

05051883

8/22/2012



# TABLE OF CONTENTS

Product Description & Application .....	Page 2-3
Safety Instructions .....	Page 4
Install Liquid Storage Tank .....	Page 5
Install Spray Nozzles .....	Page 6
Install Pump Enclosure .....	Page 7
Install System Plumbing .....	Page 8
Install In-Cab Controller & Wiring .....	Page 9
Standard Wiring Connections .....	Page 10-11
Initial Startup .....	Page 12
Controller Calibration .....	Page 13
System Operation Guidelines .....	Page 14
Controller & System Operation .....	Page 15
Controller Status & Troubleshooting .....	Page 16
Pre-wet System Troubleshooting .....	Page 17
General Maintenance .....	Page 18-19
<b>Parts</b>	
Pre-wet Kit 00016818, 3.0GPM .....	Page 20
Pre-wet Kit 00091737m 10.4GPM .....	Page 20
Pre-wet Kit 00091760, 3.0GPM Roll Spreader .....	Page 21
Controller/Harness Kits .....	Page 34
Y-Strainer .....	Page 37
Pump, 3.0GPM - 05008007 .....	Page 38
2088 Pump Operating Instructions .....	Page 39-41
Pump, 10.4GPM - 05008020 .....	Page 42
4000 Pump Operating Instructions .....	Page 43-45
Optional Liquid Tank Low Level Switch .....	Page 46
Optional Low Hydraulic Pressure Switch .....	Page 46
Optional Flush Kit .....	Page 48
Optional Quick Disconnect Kit .....	Page 49
How to Order Parts .....	Page 50
Return Policy .....	Page 50
Warranty Policy, MTE Snow & Ice Control .....	Page 51
Warranty Policy, Uninstalled Parts .....	Page 52

**NOTE:** Refer to Prewet Systems: *Tank with Mounting Hardware and Optional Accessories* under separate cover for installation and parts breakdown of these items not listed in this manual.

<b>SWP-</b>	05051883
<b>Task:</b>	Installation, Operation, Maintenance
<b>Product:</b>	LDS-333 Pre-Wet System
<b>Application:</b>	Kits 00016818, 00091737, 00091760
<b>Reference:</b>	Drawings 00016818, 00091737, 00091760



## Standard Work Procedure

### Product Description & Application

#### Product Description

The MTE LDS Electric Pre-Wet System provides pumped pre-wet chemical to spray nozzles at the point of delivery for granular materials. The system consists of an electric pump, plumbing, spray nozzles, in-cab controller, and wiring harnesses. The three available systems are:

- LDS-333: 3.0 gpm pump, two 1.0 gpm nozzles for mounting at spinner
- LDS-333-RS: 3.0 gpm pump, spray bar, eight 0.3 gpm nozzles for mounting at roll spreader
- LDS-1033: 10.4 gpm pump, three 2.0 gpm nozzles for mounting at spinner

The solid-state, in-cab controller allows the operator to manually adjust the pre-wet flow rate for desired application rate.

Pre-wet liquid tanks are sold separately from the pre-wet system to allow the end user to select a tank capacity.

#### Pre-Wet Concept

Pre-wetting granular material accomplishes two basic goals:

- Helps granular material stick to the road surface and reduces movement after the material is on the ground.
- Begins the brining process on granular salt by providing moisture.

Granular material can be pre-wetted in bulk by spraying in a storage area or in a truck bed. This practice, however, can lead to bridging and clumping of the material if it is not used immediately, and excess pre-wet liquid can run off on the ground.

Pre-wetting with nozzles at the material spreader allows the material to remain dry and loose up to that point and prevents waste of the pre-wet liquid by providing controlled flow at the spray nozzles.

#### Benefits of Pre-Wetting

- Salt can be spread more uniformly with less waste because wetted material sticks to the pavement.
- The amount of dry material used may be reduced because of the added brine and because more material stays on the road.
- Works faster because brine is already present on the salt.
- Works at a lower temperature than dry salt alone.
- Better penetration into ice and snow pack.
- Driving and spreading speeds may be increased because material stays on the road instead of bouncing off.
- Granular abrasives such as sand can be pre-wetted to help them stick to the road and penetrate snow pack faster.

<b>SWP-</b>	05051883
<b>Task:</b>	Installation, Operation, Maintenance
<b>Product:</b>	LDS-333 Pre-Wet System
<b>Application:</b>	Kits 00016818, 00091737, 00091760
<b>Reference:</b>	Drawings 00016818, 00091737, 00091760



## Standard Work Procedure

### Product Description & Application (Cont'd)

#### Pre-Wet Chemicals

The most common pre-wet liquid is salt brine at 23 to 26% concentration. Salt brine is relatively inexpensive and is typically made up in a bulk tank, then pumped into the tank(s) on the vehicle.

When temperatures are below 15° F, calcium chloride or magnesium chloride may be used to pre-wet due to their lower brining and freezing temperatures. These chemicals are much more corrosive than sodium chloride and must be used with care.

<b>CAUTION</b>		<p>Monroe Truck Equipment does not manufacture or sell chemicals for use in pre-wet systems.</p> <p>Monroe Truck Equipment can not recommend any particular chemical for the end user's application.</p> <p>The choice of pre-wet chemical, safe handling of that chemical, and adherence to environmental protection laws are the responsibility of the end user.</p>
----------------	--	--

<b>NOTE</b>		<p>Pre-wet liquid tanks and mounting kits are not covered in this manual. Choice of pre-wet tank shape, location, and volume is at the customer's discretion.</p> <p>Refer to MTE manual "Tank With Mounting Hardware and Optional Accessories" for information on pre-wet tanks.</p>
-------------	---	---

## SAFETY INSTRUCTIONS

- Read all installation, safety and maintenance instructions completely before operating this equipment.
- Keep all personnel clear of moving parts while equipment is being operated.
- Do not operate equipment in need of maintenance! Repair immediately!
- While operating this equipment use common sense, use caution, be alert and be safety-conscious.



### **DANGER**

#### **AVOID HIGH-PRESSURE FLUIDS**

Escaping fluid under pressure can penetrate the skin causing serious injury.

Avoid the hazard by relieving pressure before disconnecting hydraulic or other lines. Tighten all connections before applying pressure.

Search for leaks with a piece of cardboard. Protect hands and body from high pressure fluids.

If an accident occurs, see a doctor immediately. Any fluid injected into the skin must be surgically removed within a few hours or gangrene may result.

### **WARNING:**

Some anti-icing/de-icing/pre-wetting chemicals and/or their vapors are **NOT** compatible with 304 stainless steel and can cause damage to 304 stainless steel tanks and tank welds. Storing those types of chemicals in 304SS tanks is not recommended and may void the tank's warranty. Monroe Snow & Ice Control assumes no responsibility for damage to 304SS tanks caused by incompatible chemicals being used for anti-icing/de-icing/pre-wetting applications. Monroe Snow & Ice Control recommends that you contact your chemical supplier to check your anti-icing/de-icing/pre-wetting chemical's compatibility with 304SS prior to loading into tanks.

<b>SWP-</b>	05051883
<b>Task:</b>	Installation, Operation, Maintenance
<b>Product:</b>	LDS-333 Pre-Wet System
<b>Application:</b>	Kits 00016818, 00091737, 00091760
<b>Reference:</b>	Drawings 00016818, 00091737, 00091760



**Standard Work  
Procedure**

Look	Action	Task
------	--------	------

**Install Liquid Storage Tank**

A liquid storage tank is not provided with the LDS Pre-Wet kit. The size, mounting location, and number of tanks is at the customer's discretion.

Refer to the separate installation manual for information on MTE tank kits.

<b>SWP-</b>	05051883
<b>Task:</b>	Installation, Operation, Maintenance
<b>Product:</b>	LDS-333 Pre-Wet System
<b>Application:</b>	Kits 00016818, 00091737, 00091760
<b>Reference:</b>	Drawings 00016818, 00091737, 00091760



## Standard Work Procedure

Look	Action	Task
------	--------	------

### Install Spray Nozzles

#### Kit 00016818, 2-Nozzle System

1. Locate the two nozzle assemblies and the two shield/mounting brackets.
2. Determine the mounting location for the nozzles. This is typically on the spinner shield but may also be in the chute that drops material on to the spinner (if applicable).
3. Be sure the nozzles are located where they will spray the pre-wet liquid only on to the salt to avoid over-spray and waste of liquid.
4. Drill holes through the spinner shield and install the mounting brackets. Use stainless steel fasteners.
5. Install the nozzles in the brackets.

#### Kit 00091737, 3-Nozzle System

1. Installation of the nozzles is the same as for kit 00016818 except that there are three nozzles.
2. Position the nozzle mounting brackets as shown on drawing 00065210.

#### Kit 00091760, 8-Nozzles On Spray Bar (Roll Spreader)

1. Install the spray bar and mounting brackets at the back of the roll spreader as shown on drawings 00091760 and 00095385.
2. Install the nozzles and clamps on the spray bar. Space the nozzles evenly as shown on drawing 00095385.
3. Assemble the center distribution Tee, elbow, and quick-disconnect.
4. Install the mounting bracket for the center distribution Tee on the spray bar.
5. Install the center distribution assembly on the bracket with the supplied U-bolt as shown on drawing 00093385.



<b>SWP-</b>	05051883
<b>Task:</b>	Installation, Operation, Maintenance
<b>Product:</b>	LDS-333 Pre-Wet System
<b>Application:</b>	Kits 00016818, 00091737, 00091760
<b>Reference:</b>	Drawings 00016818, 00091737, 00091760



**Standard Work Procedure**

Look	Action	Task
------	--------	------

**Install Pump Enclosure**

1. Mount the pump enclosure using these guidelines.
  - The enclosure must be mounted using both the top and bottom flanges.
  - Choose a location at the rear of body to minimize hose length between the pump and the spray nozzles.
  - Mount the enclosure at a location where there will be easy access to the internal components.
  - Make sure there is room under the enclosure for routing and connecting hoses.
  - Make sure the enclosure door will open at least 90° for internal access.
  - Avoid locations where the enclosure could be impacted while salt is being loaded into body or where salt would continuously spill onto the enclosure.
  - Mount the enclosure at an elevation where the pump suction inlet is close to the level of the tank outlet. Ideally, the pump inlet should be at or below the level of the tank outlet.
  - The enclosure must be level and plumb when mounted.
  - Use stainless steel mounting fasteners to avoid corrosion from salt and other corrosive chemicals.

<b>CAUTION</b>		<p><b>Pump damage, loss of self-priming.</b></p> <p>The Hypro lobe pump is not self-priming when the pump suction inlet is more than 3 feet above the tank outlet. Install the Hypro pump enclosure so the pump inlet is less than 3 feet above the tank outlet.</p> <p>Good installation practice for any liquid pump is to mount the pump with the suction inlet at or below the level of the tank outlet. This insures a flooded suction at the pump and reduces priming problems.</p>
----------------	---	---

<b>SWP-</b>	05051883
<b>Task:</b>	Installation, Operation, Maintenance
<b>Product:</b>	LDS-333 Pre-Wet System
<b>Application:</b>	Kits 00016818, 00091737, 00091760
<b>Reference:</b>	Drawings 00016818, 00091737, 00091760



## Standard Work Procedure

Look	Action	Task
------	--------	------

### Install System Plumbing

#### Kit 00016818, 2-Nozzle System

1. Install the shut-off valve and the Y-strainer at the storage tank.
2. Cut a piece of hose to reach from the strainer to the pump inlet. Make the hose long enough to be routed along with other hose bundles and body structure where it can be supported and fastened.
3. Connect the hose to the strainer fitting and the pump inlet fitting. Install and tighten the hose clamps.
4. Tie the hose to the body or other hose bundles every 8" with tie wraps (zip ties).
5. Cut a short piece of hose to fit between the nozzles.
6. Cut another short piece of hose to connect the first nozzle to the check valve. The check valve must be as close to the nozzles as possible to reduce the amount of liquid that runs out of the nozzles when the pump is turned off.
7. Cut a piece of hose to reach from the strainer to the pump outlet to the check valve. Make the hose long enough to be routed along with other hose bundles and body structure where it can be supported and fastened.
8. Install the hoses from the pump outlet to the last nozzle. Be sure to install the check valve in the correct orientation (arrow on valve body).
9. Install and tighten all required clamps.
10. Tie the hoses to the body or other hose bundles every 8" with tie wraps (zip ties) as required.

#### Kit 00091737, 3-Nozzle System

1. Installation of the 3-nozzle plumbing is the same as for kit 00016818 except that there are three nozzles to be joined with hose.

#### Kit 00091760, 8-Nozzles On Spray Bar (Roll Spreader)

1. Installation of the 8-nozzle plumbing is the same as for kit 00016818 except that there are eight nozzles to be joined with hose and the pressure hose with the check valve uses a quick-disconnect to connect to the center distribution piping.

<b>SWP-</b>	05051883
<b>Task:</b>	Installation, Operation, Maintenance
<b>Product:</b>	LDS-333 Pre-Wet System
<b>Application:</b>	Kits 00016818, 00091737, 00091760
<b>Reference:</b>	Drawings 00016818, 00091737, 00091760



## Standard Work Procedure

Look	Action	Task
------	--------	------

### Install In-Cab Controller & Wiring

1. Mount the in-cab controller within easy reach of the operator.
  - Mount the controller near the center of the cab. Do not mount the controller where the driver or passenger would strike their head in the event of a front-end collision.
  - Mounting on top of the dashboard is not recommended. Mounting the controller low provides better visibility in bright sunlight.
  - Do not block access to or the view of any OEM controls or instruments.
  - If the controller is mounted to the cab floor or on a stand, make sure the seat(s) have full travel fore/aft.
2. The control panel is supplied with a mounting bracket which will allow the cab control to be angled for better viewing by the operator.
3. Remove the bracket from the controller and attach it securely to your chosen mounting location.
4. Connect red power wire to a +12 VDC power source.
  - The wire must be fused within 18" of the power connection.
  - The power to the controller should be controlled by a relay that is turned on by an ignition signal. This will turn off power to the controller when the truck is off. MTE does not recommend constant battery power to the controller.
5. Connect the black wire to the vehicle ground. The best grounding point is the negative battery post.
6. Connect console control harness and route the 30 foot long cable through the cab to rear of the vehicle. The hole the cable passes through must be grommited and sealed.
7. Connect the 15 foot long tail harness to the controller harness and route it to the pump enclosure.
8. Keep cables routed away from pinch points, sharp corners, heat sources, and other areas that may damage the wiring.
9. Connect the bare wires at the end of the tail harness to the pumping system components as shown in the drawings on the next two pages. Use crimped and soldered butt connectors and cover with heat-shrink tubing.
10. Apply dielectric grease to all connector terminals to help prevent corrosion.
11. Refer to the wiring diagrams on the next two pages.

<b>SWP-</b>	05051883
<b>Task:</b>	Installation, Operation, Maintenance
<b>Product:</b>	LDS-333 Pre-Wet System
<b>Application:</b>	Kits 00016818, 00091737, 00091760
<b>Reference:</b>	Drawings 00016818, 00091737, 00091760



**Standard Work Procedure**

Look	Action	Task
------	--------	------

**Standard Wiring Connections, LDS-333 Controller**

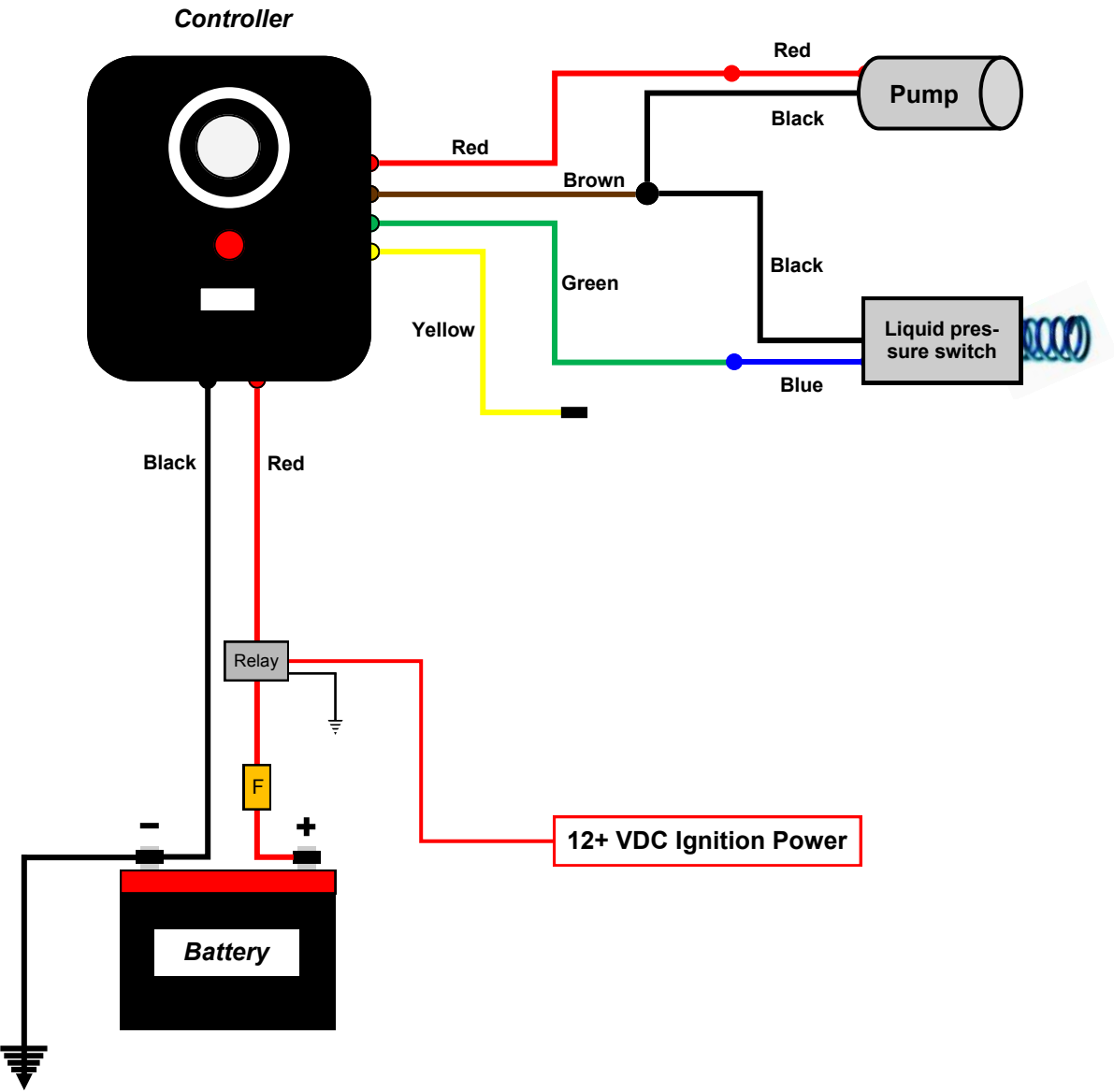

<b>SWP-</b>	05051883
<b>Task:</b>	Installation, Operation, Maintenance
<b>Product:</b>	LDS-333 Pre-Wet System
<b>Application:</b>	Kits 00016818, 00091737, 00091760
<b>Reference:</b>	Drawings 00016818, 00091737, 00091760



**Standard Work Procedure**

Look	Action	Task
------	--------	------

**Optional Wiring Connections, LDS-333 Controller**

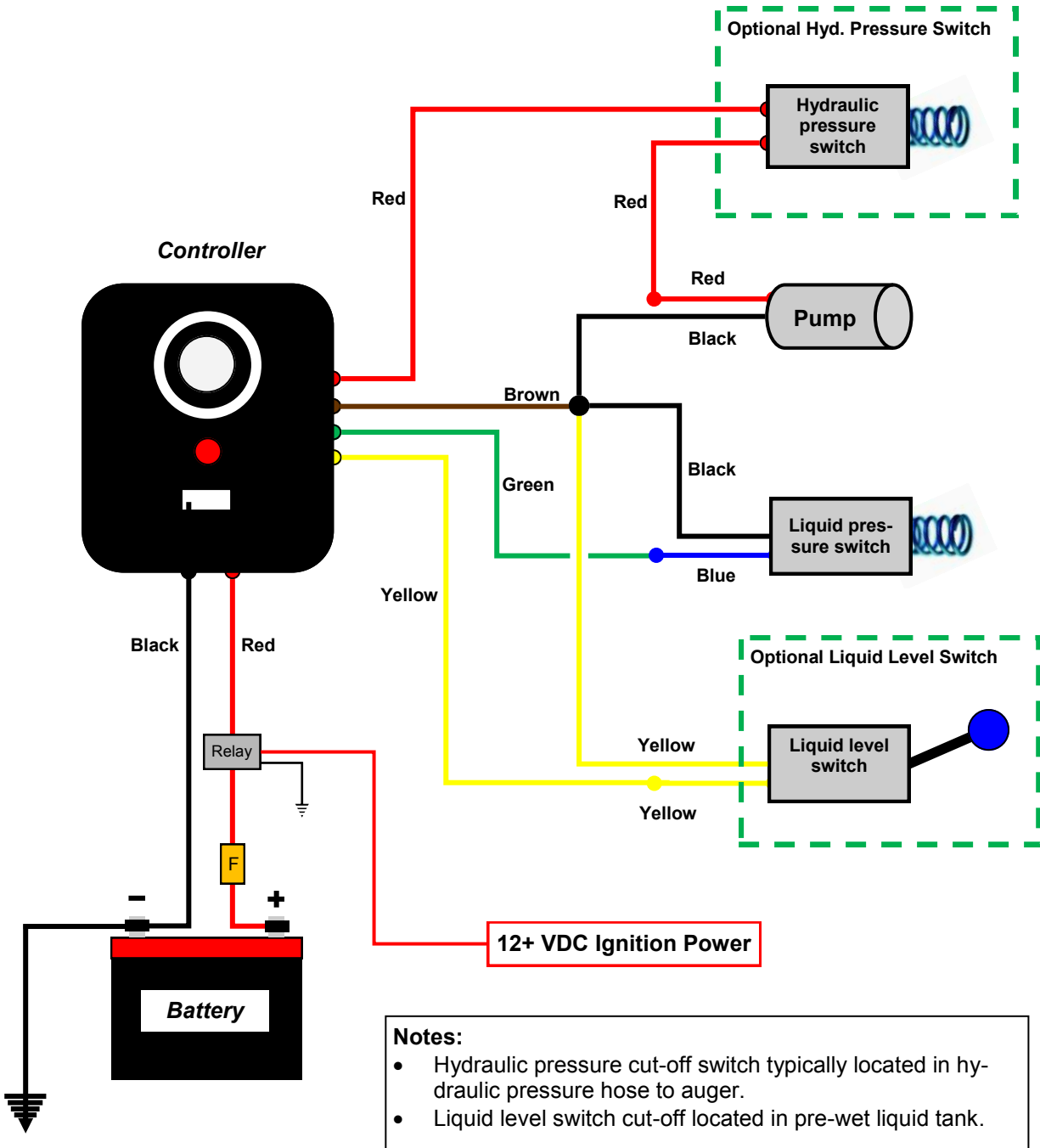

- Notes:**
- Hydraulic pressure cut-off switch typically located in hydraulic pressure hose to auger.
  - Liquid level switch cut-off located in pre-wet liquid tank.

<b>SWP-</b>	05051883
<b>Task:</b>	Installation, Operation, Maintenance
<b>Product:</b>	LDS-333 Pre-Wet System
<b>Application:</b>	Kits 00016818, 00091737, 00091760
<b>Reference:</b>	Drawings 00016818, 00091737, 00091760



## Standard Work Procedure

Look	Action	Task
------	--------	------

### Initial Startup

1. Verify that the controller has been installed and wired properly. MTE recommends that the controller be wired with an ignition-triggered relay so the power is turned off with the ignition off.
2. Verify that the controller tail harness has been properly wired to the pumping system components.
3. If the system uses the optional tank level and/or hydraulic pressure switches, verify that these switches have been installed and wired properly (Normally-Closed vs. Normally-Open option).
4. Verify that the spreader hydraulic and control system is ready for normal operation.
5. Fill the pre-wet tank(s) with the selected chemical.
6. Check for leaks at the tank fittings and repair as required.
7. Start the vehicle.
8. Set the pre-wet controller knob to a low setting and turn on the controller power.
9. If the system has a hydraulic pressure switch, the hydraulic system and spreader auger must be on.
10. Verify that the pre-wet liquid comes out of the nozzles. This may take a few seconds with an empty system.
11. Proceed the calibration steps in the next section.

<b>SWP-</b>	05051883
<b>Task:</b>	Installation, Operation, Maintenance
<b>Product:</b>	LDS-333 Pre-Wet System
<b>Application:</b>	Kits 00016818, 00091737, 00091760
<b>Reference:</b>	Drawings 00016818, 00091737, 00091760



**Standard Work Procedure**

Look	Action	Task
------	--------	------

**Controller Calibration**

Calibration of the pre-wet system defines the approximate gallons of output at the spray nozzles at each setting (1-10) on the controller.

1. Fill the pre-wet tank(s) about half way.
2. If freezing weather is not imminent, the system can be calibrated with water. In cold weather, use brine to prevent any chance of damaging piping due to freezing.
3. Place a pan or container under the spinner to catch the liquid from the spray nozzles. For the spray bar on a roll spreader installation, either use a long trough or separate containers under each nozzle.
4. Have one person stand at the nozzle area with a clock or stopwatch to time the flow at each controller setting.
5. Have a second person stay at the controller to start and stop the pre-wet pump.
6. If the system is equipped with a low-hydraulic pressure switch, the hydraulic system and auger will have to be running to perform the calibration.
7. With the controller set at "1", turn the controller on.
8. As soon as full flow is established at the spray nozzles, start timing with the clock or stopwatch. After one minute, shut the controller off.
9. Pour the collected liquid into a graduated container and record the amount of liquid. This is the gallons per minute (gpm) at that setting.
10. Place the empty container back under the spray nozzles.
11. It is not necessary to run the calibration test at each setting (1-10) on the controller dial. Test at dial settings 1 and 10, subtract to the low from the high value, divide by 9, then add this value progressively from setting 1 to determine the approximate flowrate at each setting.
12. Record the flowrate (gpm) for each controller setting in permanent reference location.
13. Use this information as directed in the next section.

<b>SWP-</b>	05051883
<b>Task:</b>	Installation, Operation, Maintenance
<b>Product:</b>	LDS-333 Pre-Wet System
<b>Application:</b>	Kits 00016818, 00091737, 00091760
<b>Reference:</b>	Drawings 00016818, 00091737, 00091760



## Standard Work Procedure

Look	Action	Task
------	--------	------

### System Operation Guidelines

1. With the spreader and pre-wet systems functional, the LDS pre-wet system can be turned on as needed.
2. Prior to a storm event, make sure the liquid tank is full of the selected pre-wet liquid.
3. Test run the pre-wet pump before use to verify that the pump runs and the spray nozzles are clear.
4. To use the system, turn the power switch on and set the output dial to the desired setting.
5. The typical pre-wet rate for granular salt is 8-12 gallons of liquid per **ton** of salt. Many operators use higher rates such as 15-18 gallons per ton of salt.
6. If granular salt is already damp, lower pre-wet rates can be used. For dry material, higher rates should be used.
7. When pre-wet liquid is sprayed on a spinner, a higher application rate is generally required as opposed to pre-wetting at the auger.
8. For granular abrasives such as sand, pre-wet rates of 10-30 gallons per ton are effective.
9. For any pre-wet application rate, the gpm settings at the controller must be related to the amount of granular material being applied and the vehicle speed during application.

**Example:** 400 lbs. of salt per lane mile @ 30 mph, desired pre-wet rate of 10 gallons/ton  
= 0.2 tons of salt and 2.0 gallons of liquid required per lane mile  
= 0.2 tons of salt will be applied in 2.0 minutes @ 30 mpg  
= 2.0 gallons/2.0 minutes = 1.0 gpm required at nozzles  
= Use controller setting that equates to 1.0 gpm at the spray nozzles.

10. Operators should keep a record book of settings used under different storm conditions, temperatures, and road speeds to develop a baseline for use of the pre-wet system.



<b>SWP-</b>	05051883
<b>Task:</b>	Installation, Operation, Maintenance
<b>Product:</b>	LDS-333 Pre-Wet System
<b>Application:</b>	Kits 00016818, 00091737, 00091760
<b>Reference:</b>	Drawings 00016818, 00091737, 00091760



## Standard Work Procedure

### Controller & System Operation



#### **NOTE**

After January of 2012, the MTE LDS Electric Pre-Wet system will be provided with a new solid-state controller manufactured by Micro-Trak Systems. The new controller (part # 05041994) is functionally identical to the previous versions of the unit and replaces both the 05041945 control panel and the MPS-MC10 controller. (When replacing an MPS-MC10 controller in the field, the entire 00065205 kit must be ordered and the new wiring harnesses used.)

#### **Controller Operation**

1. Start the vehicle engine and verify that the spreader system is ready to operate.
2. Move the toggle switch to the On position to turn the Pre-Wet system on.
3. Verify that the red LED on the controller is on (steady).
4. Turn the control knob to the desired position for Pre-Wet liquid output.
5. If the Pre-Wet controller appears to be malfunctioning, refer to the Troubleshooting information on the next page.

<b>SWP-</b>	05051883
<b>Task:</b>	Installation, Operation, Maintenance
<b>Product:</b>	LDS-333 Pre-Wet System
<b>Application:</b>	Kits 00016818, 00091737, 00091760
<b>Reference:</b>	Drawings 00016818, 00091737, 00091760



## Standard Work Procedure

### Controller Status & Troubleshooting

Controller Status	Cause	Solution
1. LED not on with power switch on	<ol style="list-style-type: none"> <li>1. No power to controller.</li> <li>2. No ground circuit.</li> <li>3. Controller defective.</li> </ol>	<ol style="list-style-type: none"> <li>1. Check power fuse and connection at power source.</li> <li>2. Check ground wiring and connection. Verify ground circuit back to battery.</li> <li>3. Replace controller.</li> </ol>
2. LED on steady	<ol style="list-style-type: none"> <li>1. Power on, system operating normally.</li> </ol>	<ol style="list-style-type: none"> <li>1. None</li> </ol>
3. LED blinks off and on, audible alarm sounds	<ol style="list-style-type: none"> <li>1. Pre-wet pump pressure low.</li> <li>2. Liquid level low in pre-wet tank (optional level switch).</li> <li>3. Auger hydraulic pressure low (optional pressure switch).</li> </ol>	<ol style="list-style-type: none"> <li>1. Check level in pre-wet tank, verify pump running, check for disconnected hose to pre-wet nozzles, check for damaged nozzle.</li> <li>2. Refill pre-wet tank, check for leaks, recalibrate pre-wet output if tank empties prematurely.</li> <li>3. Verify hydraulic system operating, check level in hydraulic oil tank, check operation of spreader control valves, check for oil leak at hydraulic hoses and fittings.</li> </ol>
5. LED blinks twice, pauses, then repeats, controller output turns off	<ol style="list-style-type: none"> <li>1. Motor leads shorted.</li> </ol>	<ol style="list-style-type: none"> <li>1. Repair wiring, reset power to controller.</li> </ol>
5. LED blinks three times, pauses, then repeats, controller output turns off	<ol style="list-style-type: none"> <li>1. High amp draw/overload at motor.</li> </ol>	<ol style="list-style-type: none"> <li>1. Check for jammed pump, shorted wiring, repair, then reset power to controller.</li> </ol>

<b>SWP-</b>	05051883
<b>Task:</b>	Installation, Operation, Maintenance
<b>Product:</b>	LDS-333 Pre-Wet System
<b>Application:</b>	Kits 00016818, 00091737, 00091760
<b>Reference:</b>	Drawings 00016818, 00091737, 00091760



## Standard Work Procedure

### Pre-Wet System Troubleshooting

Problem	Cause	Solution
Pump does not run.	<ol style="list-style-type: none"> <li>1. No power to controller.</li> <li>2. Controller defective.</li> <li>3. Power/ground circuit broken between controller and motor.</li> <li>4. Motor defective.</li> <li>5. Pump broken, jammed, or frozen.</li> </ol>	<ol style="list-style-type: none"> <li>1. Check/replace fuse. Check/repair power wire to controller.</li> <li>2. See separate controller troubleshooting chart, replace controller.</li> <li>3. Check/repair power and ground wiring.</li> <li>4. Replace motor.</li> <li>5. Check/repair/replace pump.</li> </ol>
Pump runs, low liquid flowrate.	<ol style="list-style-type: none"> <li>1. Y-strainer plugged.</li> <li>2. Kinked or crushed hose.</li> <li>3. Hose partially plugged.</li> <li>4. Spray nozzles partially plugged.</li> <li>5. Pump worn or defective.</li> <li>6. Motor defective.</li> <li>7. Controller defective.</li> </ol>	<ol style="list-style-type: none"> <li>1. Clean strainer screen.</li> <li>2. Check/repair suction and pressure hoses.</li> <li>3. Blow through hoses with compressed air.</li> <li>4. Clean spray nozzles.</li> <li>5. Check/repair/replace pump.</li> <li>6. Replace motor.</li> <li>7. See separate controller troubleshooting chart, replace controller.</li> </ol>
Pump runs, no liquid flow.	<ol style="list-style-type: none"> <li>1. Liquid storage tank empty.</li> <li>2. Y-strainer plugged.</li> <li>3. Kinked or crushed hose.</li> <li>4. Hose plugged.</li> <li>5. Spray nozzles plugged.</li> <li>6. Pump worn or defective.</li> </ol>	<ol style="list-style-type: none"> <li>1. Refill tank.</li> <li>2. Clean strainer screen.</li> <li>3. Check/repair suction and pressure hoses.</li> <li>4. Blow through hoses with compressed air.</li> <li>5. Clean spray nozzles.</li> <li>6. Check/repair/replace pump</li> </ol>

# GENERAL MAINTENANCE INSTRUCTIONS - PREWET

## In Season:

- During periods of non-use it is recommended that the system be flushed of deicing chemicals.

Example: CARGILL recommends the vehicle be steam-cleaned after each use and that the liquid system be flushed with hot water. After flushing, it is extremely important to rid the system of all water. If this is not done, the water will freeze and damage or destroy your components.

Other chemical companies may not want water used. Water used for flushing could turn the chemical into a jelly-like substance. Check with your chemical supplier for proper flush liquids.

- Inspect hoses and plumbing for leaks. Repair or replace as needed.
- Check and clean in-line strainer filter on a regular basis. (Remove bowl and screen and flush thoroughly, don't just drain).
- Inspect the nozzles for residue caking of liquid material and clean them.
- Reapply dielectric grease periodically to pins and receivers of all wiring and harness connectors to prevent corrosion of these terminals.

## Off Season Storage:

Getting the liquid system ready for summer storage will save you a great deal of time and money when fall comes for remounting.

- Fully flush the complete system including tanks. (Recommend an RV anti-freeze solution or equivalent). This will prevent high concentrations from forming and help rid system of any residue build up.
- Inspect hoses and plumbing for leaks. Repair or replace as needed.
- Drain and clean strainer.
- Disassemble and clean spray nozzles. Check for debris and renew worn components. (Make sure to reposition nozzle tips for maximum granular coverage).
- Dismount in-line poly check-valve. Flush and clean of any build up and/or debris.



**Note:** Make sure to re-install properly, matching arrow to direction of flow.

- Disassemble the brass liquid pump. Clean and inspect. Renew worn components and reassemble with a very light layer of grease to protect the bushings and gears from corroding and/or oxidizing fast.
- Reapply dielectric grease periodically to pins and receivers of all wiring and harness connectors, to prevent corrosion of these terminals.

## GENERAL INFORMATION

- Location descriptions are noted in direction of travel. (i.e. front, rear, left and right.)
- Delivery of replacement parts is subject to our sales delivery terms.
- Use only **Monroe Truck Equipment** O.E.M. replacement parts. Failure to do so will void warranty.
- Replacement parts listed in this manual reflect our most common items. If you do not find the part you require, please call your distributor.
- **Monroe Truck Equipment** reserves the right to make revisions or alterations to this parts manual.

## TORQUE CHART

SIZE	 GRADE 2	 GRADE 5	 GRADE 8
1/4-20	50 IN-LBS	75 IN-LBS	9 FT-LBS
3/8-16	15 FT-LBS	23 FT-LBS	35 FT-LBS
1/2-13	35 FT-LBS	55 FT-LBS	80 FT-LBS
5/8-11	75 FT-LBS	110 FT-LBS	170 FT-LBS
3/4-10	130 FT-LBS	200 FT-LBS	280 FT-LBS
1-8	190 FT-LBS	480 FT-LBS	680 FT-LBS
1 1/4-7	380 FT-LBS	840 FT-LBS	1360 FT-LBS

**00016818 PREWET, LDS 333, (2) 1GPM NOZZLE**

Item	Qty	Part Number	Description
1	1	00017167	PLUMBING KIT, ELECTRIC, PREWET, 3GPM, LDS 333 <i>See Page 23</i>
2	1	00065207	NOZZLE KIT, ELECTRIC UNIT, 1GPM, 2 NOZZLE <i>See Page 29</i>
3	1	00065205	CONROL/HARNESS KIT, LDS-333 <i>See Page 34</i>

**00091737 PRE-WET KIT, 12VDC, 10.4GPM, (3) 2GPM NOZZLES W/ RELIEF VALVE**

Item	Qty	Part Number	Description
1	1	00096408	PLUMBING KIT, ELECTRIC, PREWET, 10.4GPM, LDS 333 <i>See Page 25</i>
2	1	00065210	NOZZLE KIT, ELECTRIC UNIT, 2GPM, 3 NOZZLE <i>See Page 31</i>
3	1	00065205	CONROL/HARNESS KIT, LDS-333 <i>See Page 34</i>

**00091760 PRE-WET KIT, ROLL SPREADER, 12VDC 3GPM, (8) .3 GPM NOZZLE**

<b>Item</b>	<b>Qty.</b>	<b>Part Number</b>	<b>Description</b>
1	1	00095385	SPRAY BAR KIT, ROLL SPREADER <i>See Page 33</i>
2	1	00095377	PLUMBING KIT, ROLL SPREADER <i>See Page 27</i>
3	1	00017167	PLUMBING KIT, ELECTRIC PRE-WET, 3GPM <i>See Page 23</i>
4	1	00065205	CONTROL/HARNESS KIT, LDS333 <i>See Page 34</i>
5	1	05050095	TAG, SERIAL NUMBER, 1.25" X 3.5" SS

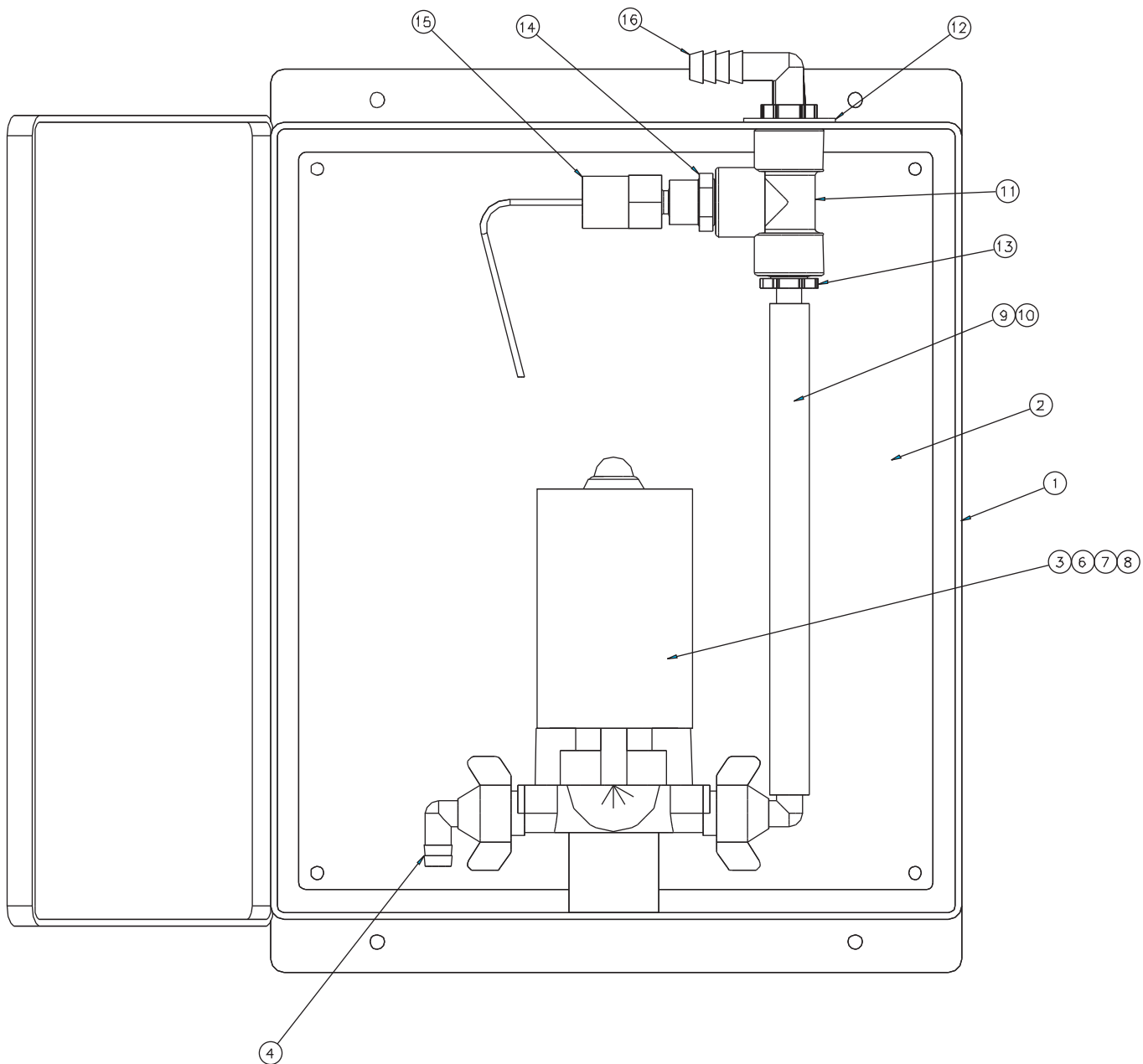



**00017167 PLUMBING KIT, ELEC, 3GPM**

<b>Item</b>	<b>Qty</b>	<b>Part Number</b>	<b>Description</b>
1	1	05041187	JUNCTION BOX, 12 X 10 X 5, NEMA
2	1	05041188	PLATE, JUNCTION BOX, 12 X 10 ALUM
3	1	05008007	PUMP, SHURFLO, 12VDC, 3GPM FLOW <i>See Page 38</i>
4	2	05037299	ELBOW, 90° SPECIAL, SHURFLO
5	1	05051625	DECAL, MONROE SNOW & ICE CONTROL <i>Not Shown</i>
6	4	05016968	SCREW #10-24 X 1.5 HX HD, 18-8
7	4	05021413	WASHER, #10, FLAT, 18-8 SS
8	4	05020964	NUT, #10-24, NYLON LOCK, 316 SST
9	2	05037281	CLAMP, HOSE, .750, SST
10	.5 FT	05037307	HOSE, .5 BLACK EPDM
11	1	05037313	TEE, .5 FEMALE NPT ALL PORTS
12	2	05021402	WASHER, .85 ID X 1.730 D
13	1	05037302	HOSE BARB, .5 X .5 MNPT, POLY
14	1	05037312	BUSHING, REDUCER, MALE, .5 MNPT
15	1	05041129	SWITCH, LOW PRESSURE WARNING
16	1	05037305	HOSE BARB, .5 X .5 MNPT, 90°
17	1	05041147	FITTING, .5, COMPRESSION, PLASTIC
18	1	05041149	NUT, .5 W/ SEAL <i>Not Shown</i>
19	1	05051883	MANUAL, LDS333 <i>Not Shown</i>

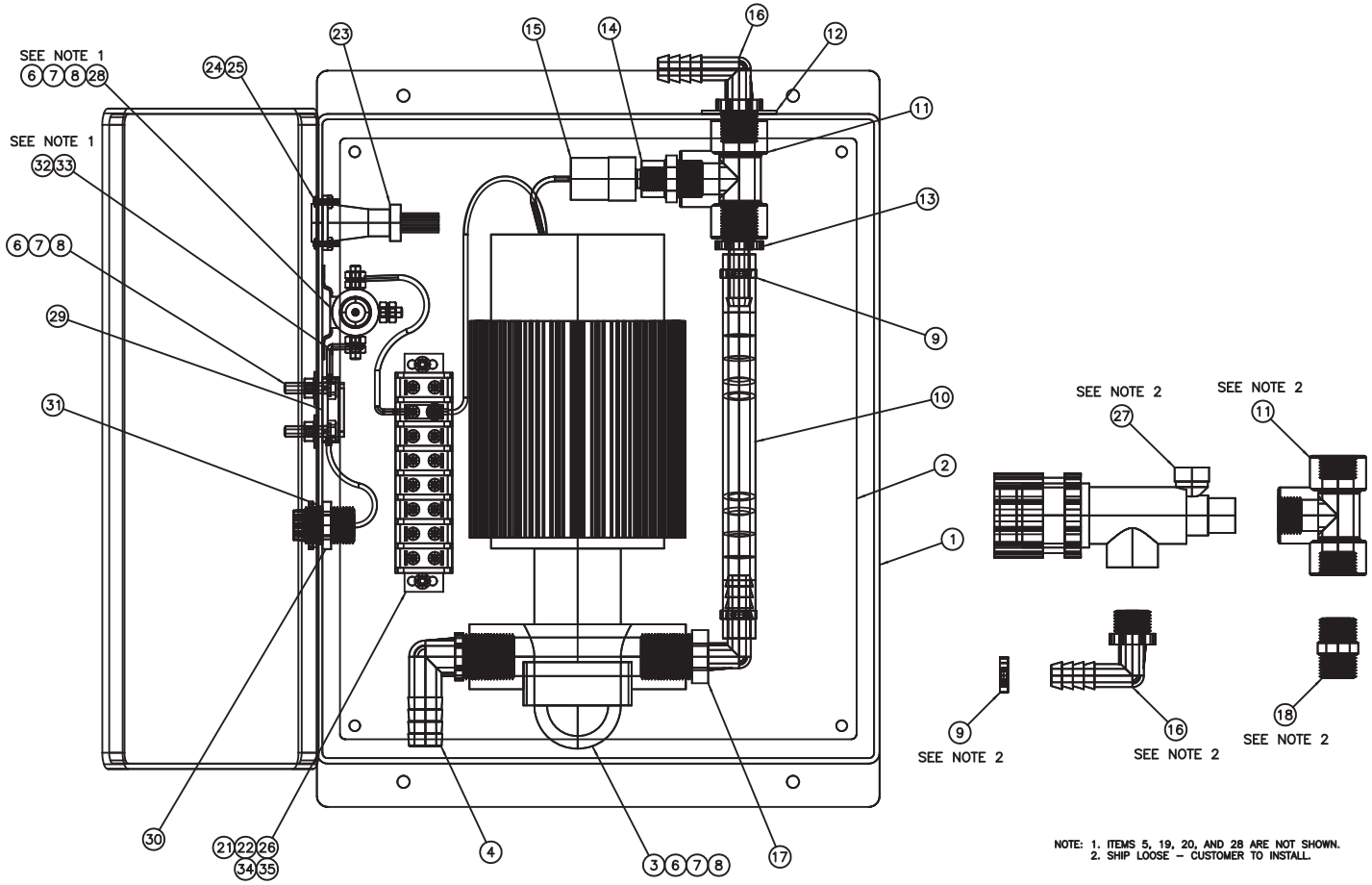

**00096408 PLUMBING KIT, PRE-WET 10.4GPM**

<b>Item</b>	<b>Qty.</b>	<b>Part Number</b>	<b>Description</b>
1	1	05041727	JUNCTION BOX, 14 X 12 X 7, NEMA
2	1	05041728	PLATE, JUNCTION BOX, 14 X 12 ALUMINUM
3	1	05008020	PUMP, AGITATION, 12 VDC, 10.4 GPM
4	1	05037304	HOSE BARB, 3/4" X 3/4" MNPT, POLY, 90 DEG
5	1	05051625	DECAL, MONROE SNOW & ICE CONTROL
6	8	05016040	BOLT, .250-20 X 1 HHCS, SST
7	8	05021403	WASHER, .250, FLAT, SST
8	8	05020906	NUT, .250-20, NYLON LOCK, 316 SST
9	3	05037281	CLAMP, HOSE, .750 SST
10	.5 FT	05037307	HOSE, .5, FLAT, EPDM, 150PSI
11	2	05037313	TEE, .5 FEMALE NPT ALL PORTS
12	2	05021402	WASHER, .85 ID X 1.73 OD X .078 THK
13	1	05037302	HOSE BARB, .5 X .5 MNPT, POLY
14	1	05037312	BUSHING, REDUCER, MALE, .5 MNPT
15	1	05041129	SWITCH, LOW PRESSURE WARNING
16	2	05037305	HOSE BARB, .5 X .5 MNPT
17	1	05037303	HOSE BARB, .5" X .75" MNPT, POLY, 90 DEG
18	1	05037314	NIPPLE, .5" NPT, SHORT, POLY
19	1	05051397	CARDBOARD BOX
20	1	05041161	TERMINAL BLOCK, DOUBLE ROW
21	1	05041162	JUMPER STRIP, TWO TERMINAL
22	1	05041365	CABLE ASSEMBLY, F/VERSACOAT & ACTIVATE
23	4	05016966	SCREW, #4-40 X .5 PH ROUND HD
24	4	05020983	NUT, #4-40 NYLON LOCK, 18-8 SST
25	2	05016956	SCREW#10-24 X 1 HX HD 18-8
26	1	05037421	VALVE, RELIEF, POLY, .5" NPT, ADJ
27	1	05041502	SOLENOID, DVDC, CONTINUOUS DUTY GROUNDED, 85 AMP
28	1	05041498	CIRCUIT BREAKER, 50AMP MANUAL RESET
29	1	05041147	FITTING, .5" COMPRESSION
30	1	05041149	NUT, .5 W/ SEAL
31	.5 FT	05051752	WIRE, 8 GA, RED
32	3	05041469	TERMINAL, RING, .4" STUD, 8GA
33	2	05020964	NUT, #10-24, NYLON LOCK, 316 SST
34	2	05021413	WASHER, #10, FLAT, 18-8 SST

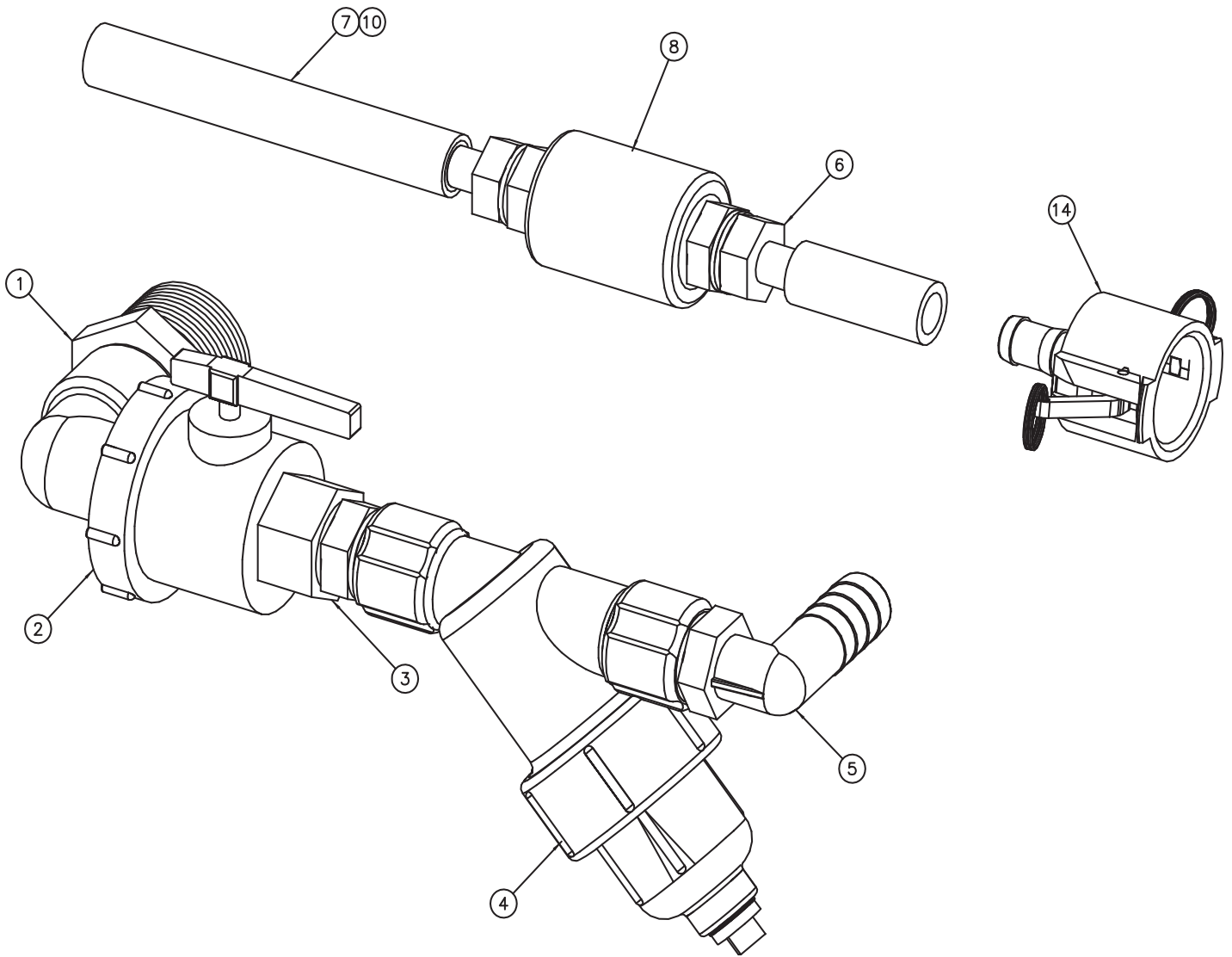

### 00095377 PLUMBING KIT, ROLL SPREADER

Item	Qty.	Part Number	Description
1	1	05037311	NIPPLE REDUCING, POLY, 1.25 MNPT X .75" MNPT
2	1	05037315	VALVE, BALL-UNION TYPE POLY, 3/4" FNPT
3	1	05037355	NIPPLE, 3/4" NPT SHORT POLY
4	1	05037309	STRAINER Y TYPE, .75" FNPT, 20 MESH SCREEN <i>See Page 37</i>
5	1	05037303	HOSE BARB, .5" X .75" MNPT, POLY
6	2	05037302	HOSE BARB, .5" X .5" MNPT, POLY, STRAIGHT
7	6	05037281	CLAMP, HOSE, .75" SST
8	1	05050202	VALVE, IN-LINE CHECK .5" NPT PVC
9	1	05050417	CLAMP, .75" CUSHIONED SST #12, 5" WIDE
10	25 FT	05037307	HOSE, .5" BLACK EPDM, 150PSI WORKING
11	1	05037464	SEALANT THREAD W/ TEFLON TRU-BLU
12	1	05037585	ELBOW, .75" NPT, POLY STRAIGHT, 90 DEG
13	1	05037301	HOSE BARB, POLY, .75" NPT X .75" BARB
14	1	05037637	COUPLING, CAM, .5" BARB X .75"

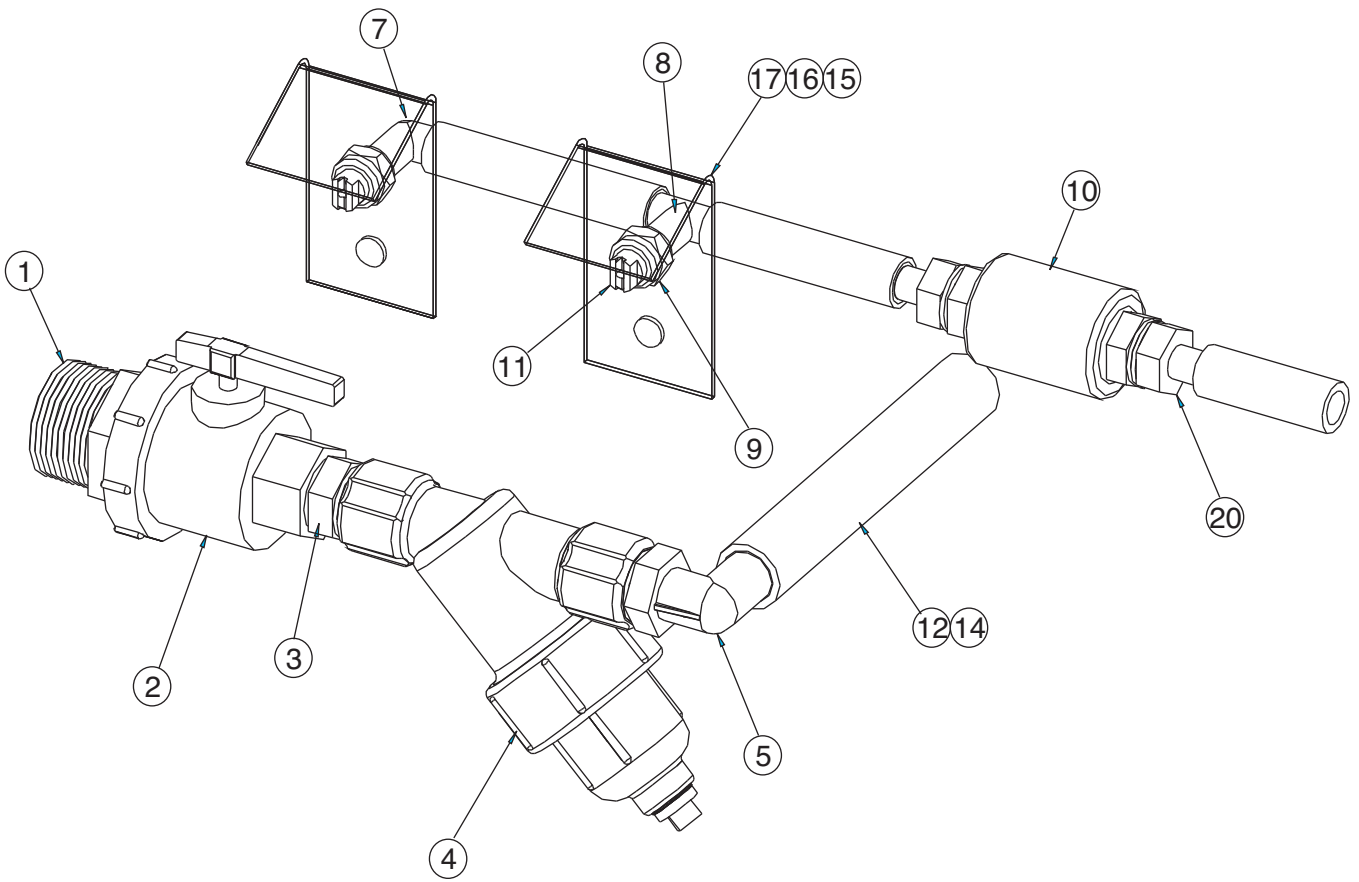

**00065207 NOZZLE KIT, HYDR UNIT, 1 GPM, 2 NOZZLE**

<b>Item</b>	<b>Qty</b>	<b>Part Number</b>	<b>Description</b>
1	1	05037311	NIPPLE, REDUCING, POLY, 1.25 MNPT X .75" MNPT
2	1	05037315	VALVE, BALL-UNION TYPE POLY, .75 FNPT
3	1	05037355	NIPPLE, .75 NPT SHORT POLY
4	1	05037309	STRAINER, Y-TYPE, .75" FNPT, 20 MESH SCREEN <i>See page 15</i>
5	1	05037303	HOSE BARB, 90°, POLY, .75 MNPT X .5 BARB
6	1	05037464	SEALANT, THREAD W/ TEFLON
7	1	05038197	NOZZLE BODY, POLY, .5 HOSE BARB, 90°
8	1	05038196	NOZZLE BODY, POLY, .5 HOSE BARB, TEE
9	2	05038179	NOZZLE CAP, BRASS
10	1	05050202	VALVE, IN-LINE CHECK, .5 NPT
11	2	05038220	NOZZLE, TIP, BRASS, 1GPM@40PSI, QUICK
12	20 FT	05037307	HOSE, .5 BLACK EPDM, 150 PSI WORKING
13	2	05050271	CLAMP, .75" ID, CUSHIONED METAL, #16 <i>Not Shown</i>
14	8	05037281	CLAMP, HOSE, .75 SST
15	5	05016040	BOLT, .25-20 X 1, HHCS, SST
16	5	05020904	NUT, .25-20, SPINLOCK, SST
17	2	00050939	SHIELD, NOZZLE, 304 SM NOZZLE
18	1	05037585	ELBOW, .75 NPT, POLY STREET, 90° <i>Not Shown</i>
19	1	05037354	HOSE BARB, POLY, .75, MNPT X .5 BARB <i>Not Shown</i>
20	2	05037302	HOSE BARB, .5 X .5 MNPT, POLY, STRAIGHT

**NOTE:** Eliminate item #17 Nozzle Shield when installing on MSPV unit. Mount the nozzle body directly to RH and LH mounting brackets.

# NOZZLE KIT, HYDRAULIC UNIT, 3 NOZZLE

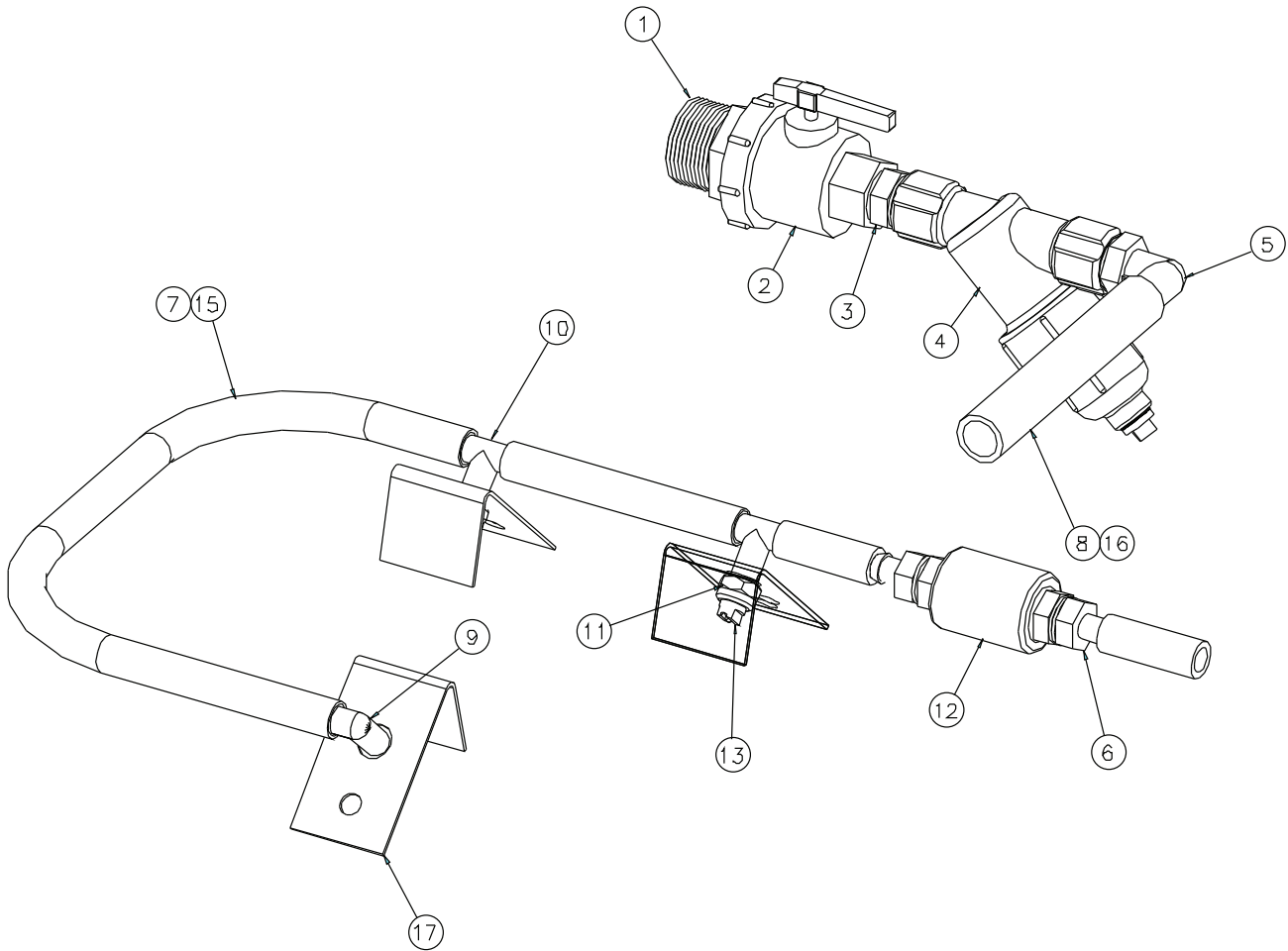



## 00065210 NOZZLE KIT, HYDRAULIC UNIT 2GPM, 3 NOZZLE, PREWET

Item	Qty.	Part Number	Description
1	1	05037311	NIPPLE, REDUCING, POLY, 1.25 MNPT X .75" MNPT
2	1	05037315	VALVE, BALL-UNION TYPE, POLY, .75 FNPT
3	1	05037355	NIPPLE, .75" NPT SHORT POLY
4	1	05037309	STRAINER, Y-TYPE, .75 FNPT, 20 MESH SCREEN <i>See Page 37</i>
5	1	05037304	HOSE BARB, 90 DEG, POLY, .75 MNPT X .75 BARB
6	2	05037302	HOSE BARB, .5 X .5 MNPT, POLY, STRAIGHT
7	8	05037281	CLAMP HOSE, .75 SST
8	2	05037300	CLAMP HOSE, 1 SS
9	1	05038197	NOZZLE BODY, POLY, .5 HOSE BARB, 90 DEG
10	2	05038196	NOZZLE BODY, POLY, .5 HOSE BARB, TEE
11	3	05038179	VALVE, IN-LINE CHECK,
12	1	05050202	VALVE, IN-LINE CHECK, .5 NPT, PVC
13	3	05038198	NOZZLE, TIP, BRASS, 2GPM@50PSI, QUICK
14	1	05050271	CLAMP, CUSHIONED METAL, .75", #12
15	20 FT	05037307	HOSE, .5 BLACK EPDM, 150 PSI WORKING
16	5 FT	05037308	HOSE, .75 BLACK EPDM, 150PSI WORKING
17	3	00050939	SHIELD, NOZZLE, PREWET
18	3	05016138	BOLT, .313-18 X 1, HHCS, SST
19	3	05020901	NUT, .313-18 SPINLOCK, SST
20	1	05016040	BOLT, .250-20 X 1, HHCS, SST
21	1	05020904	NUT, .250-20 SPINLOCK, SST
22	1	05037464	SEALANT, THREAD W/ TEFLON, TRU-BLU
23	1	05037585	ELBOW, .75 NPT, POLY, STREET, 90 DEG
24	1	05037301	HOSE BARB, POLY, .75" NPT X .75" BARB

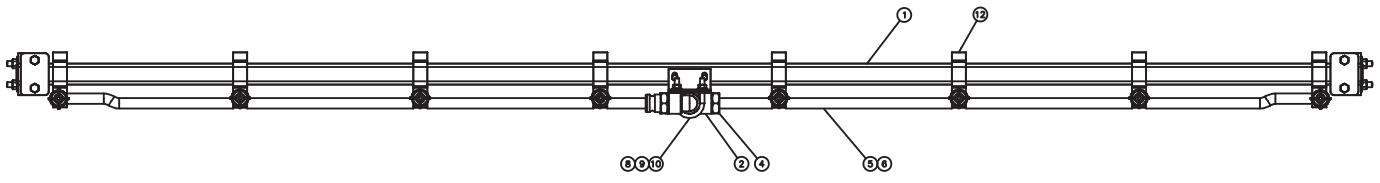
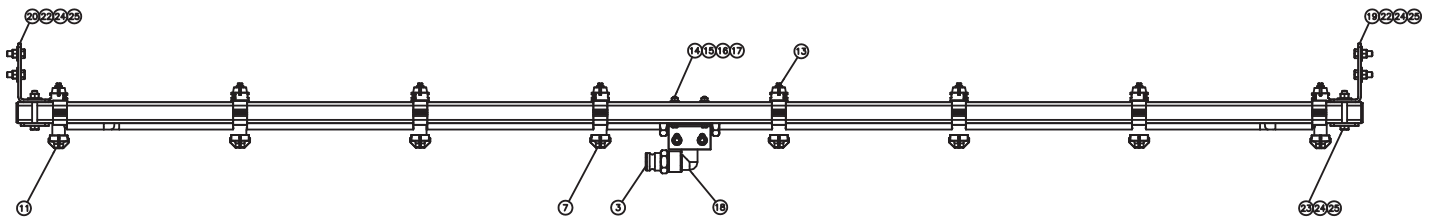

**00095385 SPRAY BAR KIT, ROLL SPREADER, ELECTRIC, 3GPM, PRE-WET**

Item	Qty.	Part Number	Description
1	1	00095384	MOUNTING BAR WELDMENT, SPRAY BAR
2	1	05037965	TEE, .75" FNPT, ALL PORTS, POLY
3	1	05037457	COUPLER, POLY, .75" MNPT X MALE ADAPTER
4	2	05037354	HOSE BARB, POLY, .75" MNPT X .5" BARB
5	7.5 ft	05037307	HOSE, .5" BLACK EPDM 150PSI WORKING
6	16	05037281	CLAMP, HOSE, .75" SST
7	6	05037836	NOZZLE BODY, POLY, DRY BOOM
8	1	05016937	U-BOLT, ROUND .313-18, 1.5 X 2.188, 304
9	2	05021404	WASHER, .313, FLAT, SST
10	2	05020907	NUT, .313-18 NYLON LOCK, 316 SST
11	2	05037837	NOZZLE BODY, POLY, DRY BOOM ONE .5" BARB
12	8	05050576	CLAMP, TEEJET NOZZLE FOR 1.5" SQ TUBE
13	8	00095376	NOZZLE KIT, QUICK CHANGE, .3 GPM@40PSI
14	1	00085988	BRACKET, MOUNTING, SPRAY BOOM, ASESU, 10GPM
15	2	05010597	BOLT, .250-20 X 2, G8, HHCS, ZINC
16	2	05021305	WASHER, .250, FLAT, ZINC
17	2	05020899	NUT, .250-20, TOP LOCK, ZINC
18	1	05037585	ELBOW, STREET, .75" NPT 90 DEG, POLY
19	1	00095378-A	BRACKET, BOOM MOUNT, RH, MS
20	1	00095379-A	BRACKET, BOOM MOUNT, LH, MS
21	2	00095380-A	ATTACHMENT PL, BOOM MOUNT, MS
22	4	05010643	BOLT, .375-16 X 1.G8, HHCS, ZINC
23	4	05010649	BOLT, .375-16 X 2.50, G8, HHCS, ZINC
24	8	05020898	NUT, .375-16, GC, TOP LOCK, C&W
25	8	05021307	WASHER, .375, FLAT, MC, YZ

## 00041340 CONTROL/HARNESS KIT, LDS 333

Item	Qty	Part Number	Description
1	1	MPS-MC10	CONTROLLER, MC10
3	1	MPS-MC10IC	CABLE, INTERCONNECT, MC10
4	1	MPS-MC10PGVSC	CABLE, POWER/GROUND/VALVE
5	1	05050307	CARDBOARD BOX

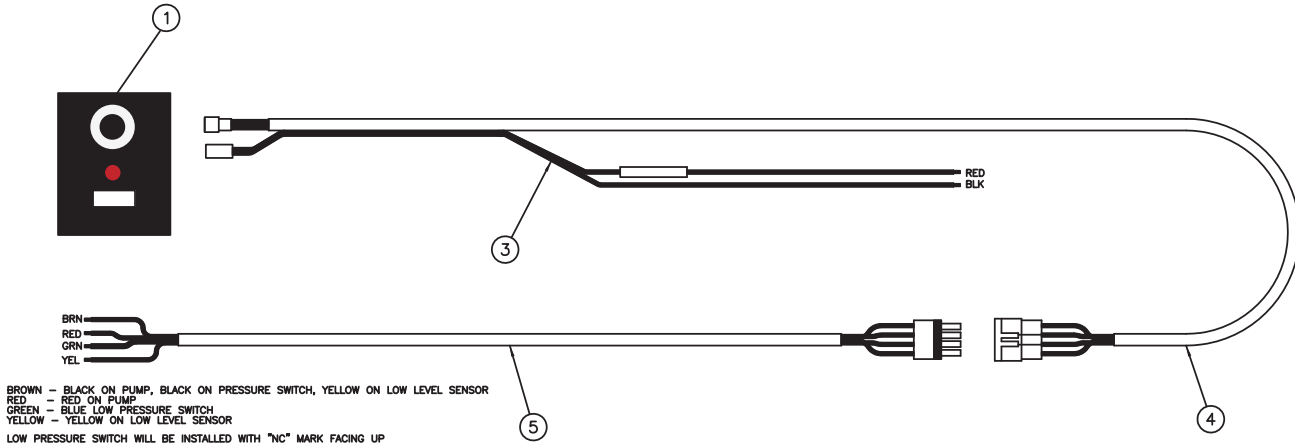

## 00065205 CONTROL/HARNESS KIT, LDS 333

Item	Qty	Part Number	Description
1	1	05041994	CONTROLLER, LDS333, MC10, 12VDC
3	1	05041174	WIRE HARNESS, FUSED, TRUCK TO CONTROL
4	1	05040379	CABLE ASSEMBLY, TRUCK PORTION, 30' OAL
5	1	05040381	CABLE ASSEMBLY, TAIL PORTION, 15' OAL

# ***Service Bulletin***

**Subject: New LDS-333 controller & wiring connections**

**Description:**

After January of 2012, the MTE LDS-333 Pre-Wet system will be provided with a new solid-state controller manufactured by Micro-Trak Systems. The new controller (part # 05041994) is functionally identical to the previous version of the unit.

The purpose of this Service Bulletin is to clarify the wiring connections between the controller and the pre-wet system components. This information will be incorporated into the Service & Parts manual for the LDS-333 system.

# MTE Service Bulletin

## Wiring Connections, LDS-333 Controller

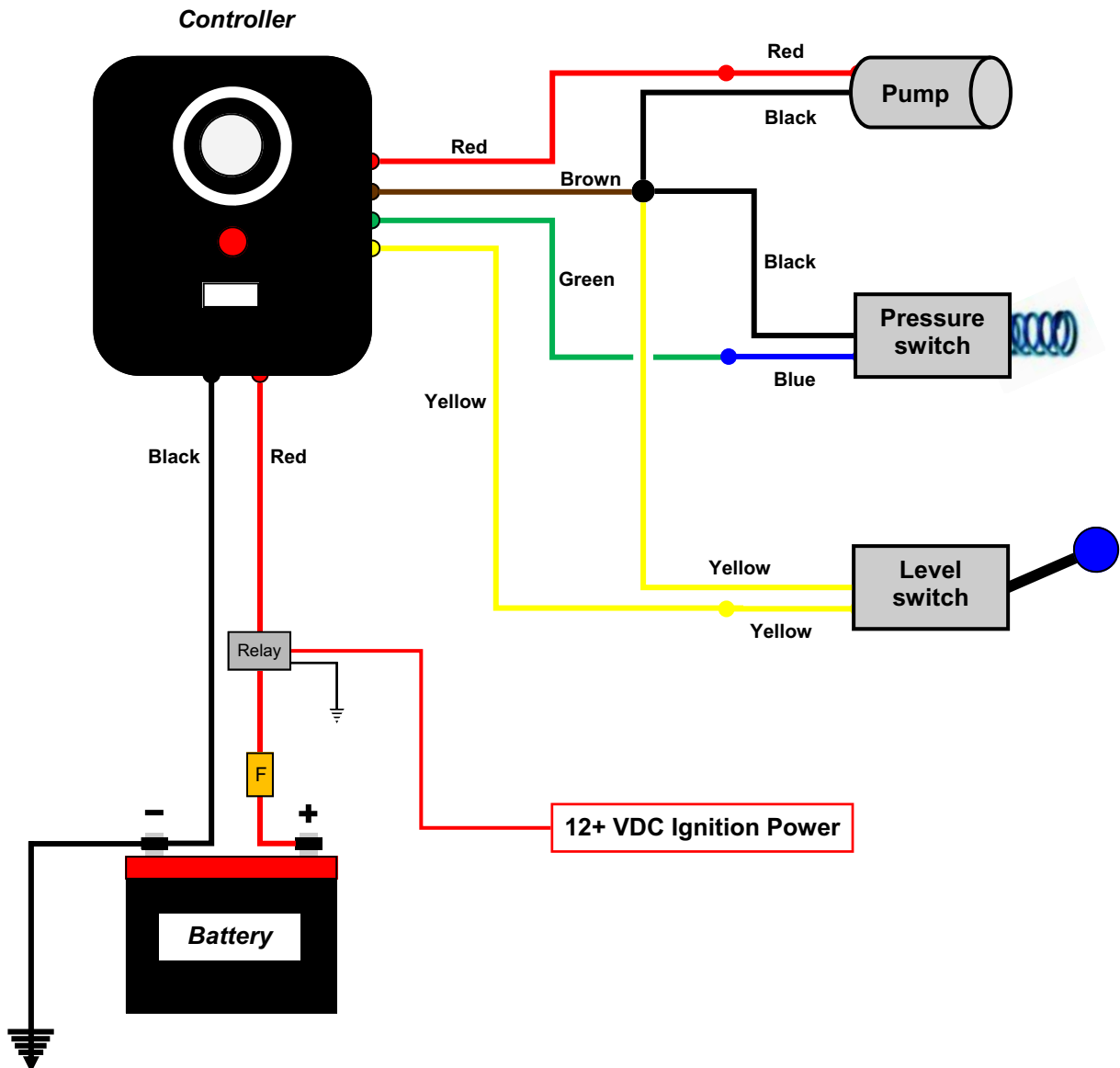

Monroe Truck Equipment, Inc.  
1051 W. 7<sup>th</sup> Street  
Monroe, WI 53566

Bulletin #: SB-00246

Release Date: 01/05/12

Revision Date:

# WIRING SCHEMATIC LDS-333 USED PRIOR TO JUNE 2007



## 05041945 PANEL, CONTROL ASSEMBLY

Item	Qty	Part Number	Description
1	1	05041439	SWITCH, TOGGLE, OFF/ON
2	1	05041440	KNOB, RATE CONTROL
3	2	05041441	LIGHT, RED, LED, WARNING

**05037309 STRAINER, Y-TYPE, 3/4" FNPT, 20 MESH SCREENS**

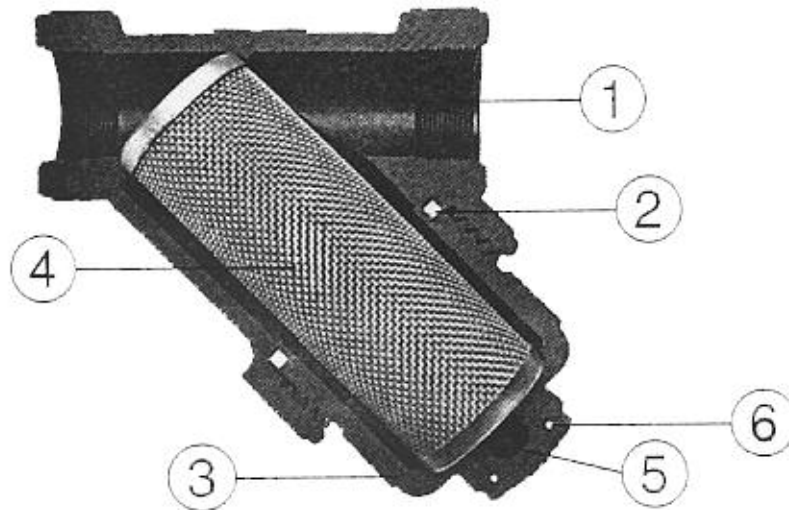

ITEM	QTY	PART #	DESCRIPTION
1	1	05039528	Y" Body and Cap
2	1	05038107	Gasket
3	1	05038564	End Cap
4	1	05038392	20 Mesh Screen
5	1	05038563	1/4" Drain Plug
6	1	05039534	EPDM O-Ring for Drain Plug

## 05008007 PUMP, SHURFLO, 12 VDC, 3GPM

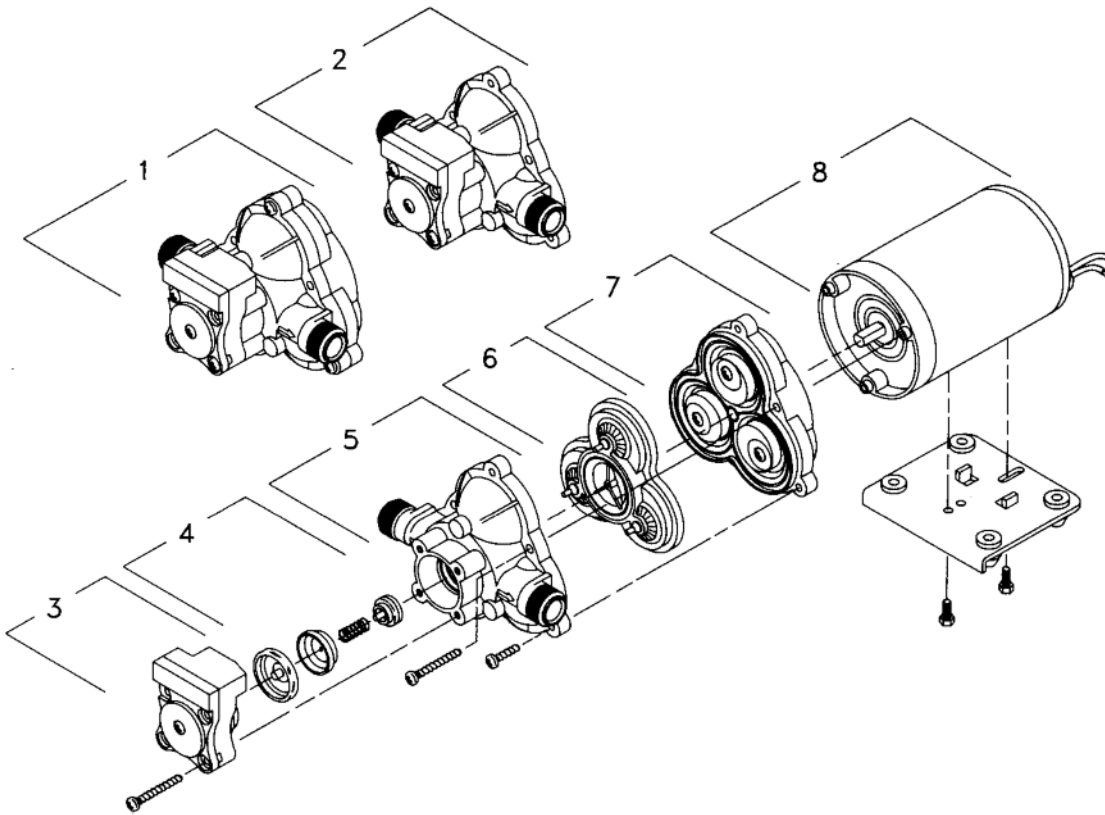

ITEM	QTY	PART #	DESCRIPTION
1	1	05008092	Pump Head
2	1	05008093	Upper Housing/Switch Assembly
3	1	05008094	Switch Assembly
4	1	05008095	Check Valve Assembly
5	1	05008096	Upper Housing
6	1	05008097	Valve Assembly
7	1	05008098	Diaphragm / Drive Assembly
8	1	05008099	Motor





## 2088 INDUSTRIAL SERIES PUMPS

### **Installation and Operation Manual**

SHURflo offers various pumps models for different applications. The information outlined by this manual is general, and not specific to all 2088 series pumps. Be certain the pumps' materials will be compatible with the fluid being pumped. 2088 series pumps are intended for intermittent or continuous duty when the proper operating criteria is met. Product Data Sheets outlining specific thermal limits, load, flow curves, and other technical information for a particular model are available. If unsure of the chemical compatibility with a given elastomer or the motors intended design, please call SHURflo for assistance.

**CAUTION:** "Intermittent Duty" is defined as: operated and/or frequently started within a period of time that would cause the motor to reach its maximum thermal limits. Once the maximum thermal limit is obtained, the motor must be allowed to return to ambient temperature before resuming operation.

**CAUTION:** *DO NOT* use to pump flammable liquids. Never operate the pump in an explosive environment. Arcing from the motor brushes, switch or excessive heat from an improperly cycled motor may cause an explosion.

**CAUTION:** *DO NOT* assume fluid compatibility. If the fluid is improperly matched to the pumps' elastomers, a leak may occur. Pumps used to transfer hazardous or hot (max. temperature 170°F [76°C] viton only) chemicals must be in a vented area to guard against the possibility of injury due to harmful or explosive liquid/vapors.

**CAUTION:** *DO NOT* operate the pump at pressures which cause the motor to exceed the amperes rating indicated on the name plate. Various pump models are equipped with thermal breakers to interrupt operation due to excessive heat. Once the temperature of the motor is within proper limits it will automatically reset, and the pump will start operation without warning.

**CAUTION:** To prevent electrical shock, disconnect power before initiating any work. In the case of pump failure, the motor housing and/or the pumped fluid may carry high voltage to components normally considered safe.

### **PRESSURE SWITCH OPERATION**

The pressure switch reacts to outlet pressure, and interrupts power at the preset shut-off pressure indicated on the pump label. When outlet pressure drops below a predetermined limit (typically 15-20 psi.[1-1.4 bar] less than the shut-off pressure), the switch will close and the pump will operate until the shut-off (high) pressure is achieved. The shut-off pressure is set to factory calibrated standards. See the motor label and Product Data Sheet for specific pump specifications.

**CAUTION:** Improper adjustment of the pressure switch, may cause severe overload or premature failure. Refer to SHURflo Service Bulletin #1031 for the adjustment procedure. Failures due to improper adjustment of the pressure switch will not be covered under the limited warranty.

If the plumbing is restrictive or the flow rate is very low, the pump may re-pressurize the outlet faster than the fluid is being released causing rapid cycling (ON/OFF within 2 seconds). If the pump is subjected to rapid cycling during normal operation, or for infrequent periods, damage may occur. Applications which exhibit rapid cycling should have restrictions in the outlet minimized. If not feasible considered a SHURflo Accumulator or a SHURflo "bypass" model pump.

### **BYPASS OPERATION**

A bypass pump may be used for applications that normally induce frequent start/stop of the motor, and thereby create a potential for overheating. Models equipped with an internal bypass are designed to pump at high pressure while at low flow rates. Bypass models equipped with a switch may operate for several seconds even though the outlet side has been closed off. Contact SHURflo for information regarding bypass pumps.

# **SHURflo**

## **MOUNTING**

- The 2088 series pumps are self priming. Horizontal and vertical prime vary depending on the fluid viscosity and pump configuration. Refer to the pumps Product Data Sheet.
- The pump should be located in an area that is dry and provides adequate ventilation. If mounted within an enclosure, provisions to cool the motor may be necessary. Heat sinks which attach to the motor are available from SHURflo if increased heat dissipation is necessary.

**CAUTION:** **DO NOT** locate the motor near low temperature plastics or combustible materials. The surface temperature of the motor may exceed 250°F [120°C]. Refer to the pumps Product Data Sheet.

- The pump may be mounted in any position. However, if mounting the pump vertically the pump head should be in the down position so that in the event of a leak, fluid will not enter the motor.
- Secure the rubber feet with #8 hardware. **DO NOT** compress the feet, doing so will reduce their ability to isolate vibration/noise.

## **PLUMBING**

- Flexible high pressure tubing compatible with the fluid should be used to connect the inlet/outlet ports. Tubing should be either 3/8" or 1/2" [10 or 13 mm] I.D., and at least 18 in. [46 cm] length is suggested to minimize stress on the fitting/ports and reduce noise. Allow for the shortest possible tubing route and avoid sharp bends that may kink over time.

**NOTE:** Restrictions on the inlet may cause vacuum levels to reach the fluid vapor pressure, causing cavitation, degassing, vapor lock and a loss in performance. Inlet pressure **must** not exceed 30 psi [2.1 bar] maximum.

- **1/2" Male threaded models:** Are intended to be used with SHURflo Swivel Barb Fittings which seal with an internal taper when **hand tightened**. Standard 1/2" NPT fittings may be used when tightened to a maximum torque of 3.7ft/Lb (45in/Lb) [5Nm].

**NOTE:** SHURflo does not recommend the use of metal fittings or rigid pipe to plumb the inlet/outlet ports. Standard plastic male and female threaded fittings can be acquired at commercial plumbing supply stores. SHURflo also distributes Swivel Barb Fittings, and special fitting through it's dealers (Form #07-010-0011).

**CAUTION:** Sealers and Teflon tape may act as lubricant causing cracked housings or stripped threads due to over-tightening. Care should be used when applying sealers. Sealers may enter the pump inhibiting valve action, causing no prime or no shut-off. **Failures due to foreign debris is not covered under warranty.**

- Installation of a 50 mesh strainer is recommended to prevent foreign debris from entering the pump.
- If a check valve is installed in the plumbing, it must have a cracking pressure of no more than 2 psi [.14 bar].

## **ELECTRICAL**

**CAUTION:** Electrical wiring should be performed by a qualified electrician, in accordance with all local electrical codes.

- The pump should be on a dedicated (individual) circuit, controlled with a double pole switch (U.L./C-UL certified) rated at or above the fuse ampere indicated by the pump motor label. Depending on distance of the power source from the pump and ampere load on the circuit, wire may need to be heavier than indicated by the chart.

**CAUTION:** All 115 VAC and 230 VAC pump motors and systems, **MUST** be ground per local and state electrical codes.

- Improper duty cycle and/or rapid start & stop conditions may cause the internal thermal breaker (if equipped) to trip, or can result in premature motor failure due to excessive heat. Refer to the pumps Product Data Sheet.

- For the pump to meet U.L./C-UL requirements the circuit **MUST** be protected with a slow-blow fuse (U.L./C-UL certified) or equivalent circuit breaker as indicated on the motor label. Use an approved wire of the size specified or heavier.

VOLTAGE FUSE RATING	WIRE LEADS	WIRE SIZE	
12 DC	RED (positive +) BLACK (negative -)	#14 AWG [2.5 Mm <sup>2</sup> ] (or heavier)	SEE PUMP MOTOR LABEL
24 DC			
36 DC			
115 AC	BLACK (common) WHITE (neutral) GREEN (ground)	#16 AWG C-UL - TEW / UL 1015	
230 AC	BLACK (common) BLUE (neutral) GRN/YELL (ground)	(or heavier) [1Mm <sup>2</sup> ]	

VDE requires a fuse (slow blow) or equivalent circuit

**CAUTION:** Circuit protection is dependent on the individual application requirements. Failure to provide proper overload / thermal devices may result in a motor failure, which will not be covered under warranty.

## TROUBLESHOOTING

### PUMP WILL NOT START:

equipped)

- ✓ Fuse or breaker`
- ✓ For correct voltage (±10%) and electrical connections
- ✓ Pressure switch operation and correct voltage at switch or motor wires (as equipped)
- ✓ Rectifier or motor for open or grounded circuit
- ✓ For locked drive assembly

### WILL NOT PRIME: (No discharge/Motor runs)

- ✓ Out of product
- ✓ Strainer for debris
- ✓ Inlet tubing/plumbing for severe vacuum leak
- ✓ Inlet/Outlet tubing severely restricted (kinked)
- ✓ Debris in pump inlet/outlet valves
- ✓ Proper voltage with the pump operating (±10%)
- ✓ Pump housing for cracks

### LEAKS FROM PUMP HEAD OR SWITCH:

- ✓ For loose screws at switch or pump head.
- ✓ Switch diaphragm ruptured or pinched
- ✓ For punctured diaphragm if fluid is present at bottom drain

## SERVICE KITS

Kits are readily available to repair standard 2088 series pumps. Repair kits include simple illustrated instructions allowing easy installation. To insure that the correct kit is received the model numbered and all name plate data must be included with the order. Contact a SHURflo distributor or SHURflo directly to order the necessary repair kit.

1	Switch / Check valve and Upper Housing Kit (Replaces all previous switch designs)
2	Valve plate assembly
3	Diaphragm / Drive Assembly
4	Motor
5	Complete Pump Head assembly (includes parts #1,2,3) (Replaces all previous switch designs)

### PUMP WILL NOT SHUT-OFF: (Pressure switch

- ✓ Output line closed and no leaks
- ✓ For air trapped in outlet line or pump head
- ✓ For correct voltage to pump (±10%)
- ✓ Inlet/Outlet valves for debris or swelling
- ✓ For loose drive assembly or pump head screws
- ✓ Pressure switch operation/adjustment incorrect refer to SB #1031 for differential and pressure adjustment procedure

### NOISY / ROUGH OPERATION:

- ✓ Mounting feet that are compressed to tight
- ✓ Does the mounting surface multiply noise (flexible)
- ✓ For loose pump head or drive screws
- ✓ Is the pump plumbed with rigid pipe causing noise to transmit

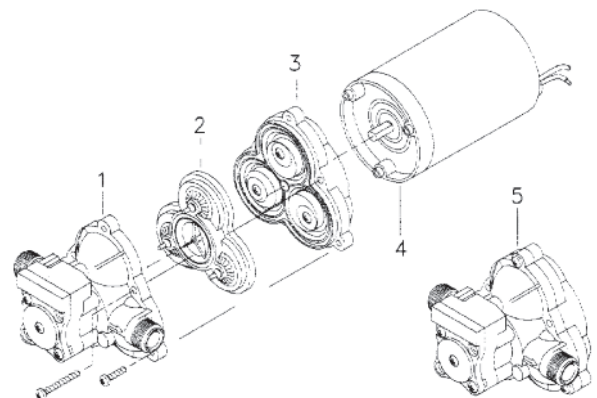

## 05008020 PUMP, AGITATION, 12 VDC

**[NOTE]**

When ordering parts, give QUANTITY, PART NUMBER, DESCRIPTION and COMPLETE MODEL NUMBER. Reference numbers are used ONLY to identify parts in the drawing and are NOT to be used as order numbers.

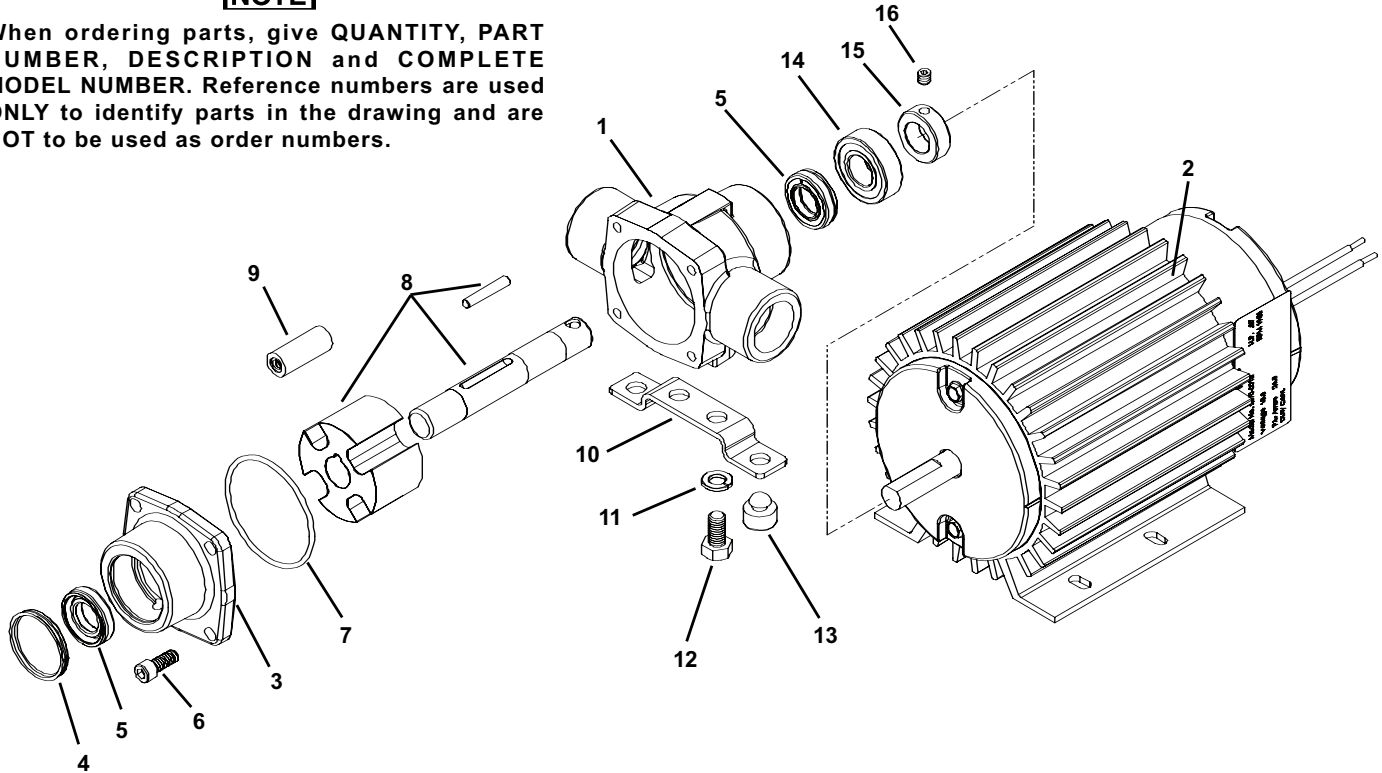

### 05008020 PUMP, AGITATION, 12 VDC PARTS LIST

ITEM	QTY	PART #	DESCRIPTION
1	1	05008108	Body, SilverCast, With STD Seal
2	1	05008109	Endplate, SilcerCast, With STD Seal
3	1	05008110	Rotor & Shaft Assembly, SilverCast
4	1	05008111	Rotor Set Screw, SilverCast
5	4	05008112	Super Rollers, STD
6	1	05008113	O-Ring Gasket For Endplate
7	4	05008114	Endplate Screw
8	2	05008115	Viton Seal, STD
9	2	05008036	Ball Bearing
11	1	0008116	Bearing Cover
12	1	05008117	Locking Collar
13	1	05008118	Set Screw
14	1	05008119	Base
15	2	05008120	Bumper
16	1	05008121	Electric Motor, E2, 12 VDC, Black
17	1	05008122	Complete Roller Pump Assembly <i>(Not Shown)</i>
18	2	05008123	Bolt
19	2	05008124	Lock Washer
20	2	05008125	Torsion Spring, .33 hp <i>(Not Shown)</i>
21	2	05008126	Brush Assembly, .33 hp <i>(Not Shown)</i>
22	2	05008127	Torsion Spring, .39 hp <i>(Not Shown)</i>
23	2	05008128	Brush Assembly, .39 hp <i>(Not Shown)</i>

## Installation Instructions

### PLUMBING HOOK-UP

See Figure 1 for recommended plumbing installation.

#### INLET LINE

Use a 3/4" 2-braid suction hose or 3/4" pipe to prevent collapsing. Avoid all unnecessary bends, elbows, or kinks in the inlet line. Loops in the inlet line will permit air to be trapped in the line, preventing the pump from priming. Make sure all connections are tight and do not leak air.

#### STRAINER

A strainer should be installed on the inlet side of the pump.

#### NOTE

Check the strainer periodically to ensure that it is not clogged with debris.

#### DISCHARGE HOSE AND FITTINGS

Use only hose, pipe, pipe fittings, and accessories that are rated at or above the maximum operating pressure of the pump.

#### PRIMING

This pump is not designed to "self prime" more than 3 ft. [0.9 m] above liquid level. Ideally, the pump should be located below the tank. If this is not possible, a pipe

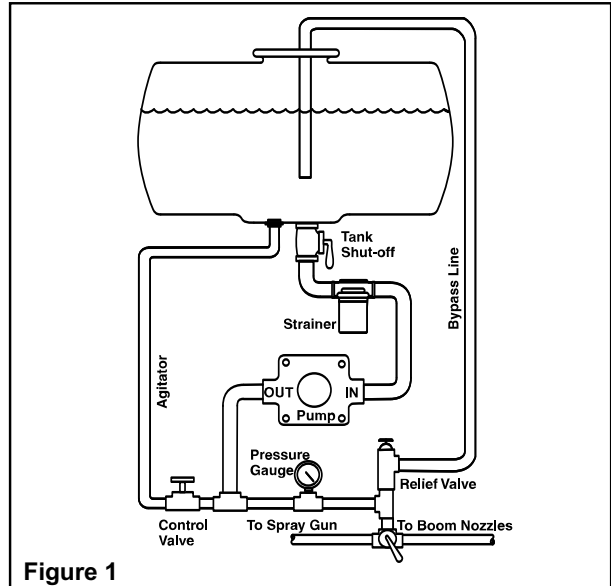

Figure 1

tee should be installed in the inlet line to allow liquid to be poured into the inlet line to facilitate priming. Installation of a foot valve is also recommended onto the inlet line on the bottom of the tank (See Figure 1).

#### NOTE

Make certain all inlet fittings are tight. Loose or leaking fittings will decrease the pump's ability to prime.

### ELECTRICAL HOOK-UP

#### NOTE

The motor must be fused to protect the electrical system. Use a 30 amp slow-blow fuse or circuit breaker.

The motor lead wires are identified with (+) and (-) tags on each corresponding lead wire. For proper pump rotation, the connections should be made as follows:

- Positive Motor Lead (+) to Positive Power Lead (Red, +).
- Negative Motor Lead (-) to Negative Power Lead (Black, -).

### ON/OFF TOGGLE SWITCH INSTALLATION

See Figure 2.

1. The ON/OFF Switch must be rated at or above 35 amps.
2. If additional lead wire is required, use 10 gauge or larger wire.
3. Performance may be improved by shortening the motor lead wires. Minimize wire length where possible.

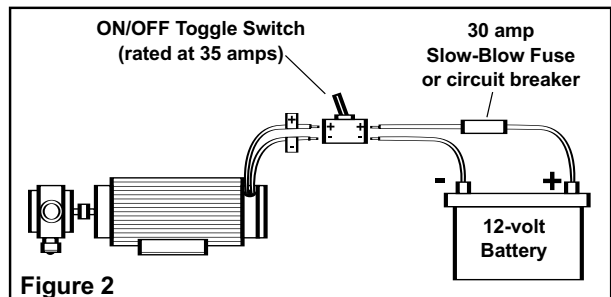

Figure 2

## Fertilizer Application (Special Instructions)

Popular uses for the 4101N-E2H include starter fertilizer application for row crop planting. Starter fertilizer is heavier than water per gallon (approx. 1.40 specific Gravity) and is also more viscous. These two characteristics will affect the performance as compared to water like herbicide/pesticide applications. Refer to the Performance Chart on page 5 for examples of performance using 10-34-0 fertilizer.

### **[NOTE]**

**Liquid fertilizers also have a tendency to cause gumming if left in the pump. Thoroughly flush the pump after each use as described in Care of the Pump.**

## Care of the Pump

### **[NOTE]**

**Before starting the pump, make sure it can be freely rotated by hand.**

### TIGHT PUMP

#### **CORROSION**

If the rotor is stuck due to rust or failure to clean the pump after use, the rotor can be freed by loosening each endplate bolt one full turn.

### **[NOTE]**

**A few drops of oil poured into the ports will help free the rotor.**

Using an adjustable wrench, turn the shaft to break the rotor loose. Keep turning the shaft as the endplate bolts are alternately and evenly tightened.

#### **FOREIGN OBJECT**

If something is lodged in the pump (wire, straw, rust flake, stick, etc.), the pump will have to be partially disassembled to remove the object. Refer to Hypro Form L-0100R for disassembly instructions.

### LUBRICATION

This pump is equipped with factory-lubricated ball bearings and requires no further lubrication. Do not allow kerosene or oil to enter into the ball bearings as this will wash the grease out of the ball bearings. The two drain holes under the bearing housings serve to relieve the

pressure behind the bearing seals and prevent any liquid which may get behind the bearing seals from being forced into the ball bearings. Do not plug or inject oil into these two drain holes. Excessive dripping from these drain holes indicates seal or shaft wear and these worn parts must be replaced. Refer to Hypro Form L-0100R for repair instructions.

### AFTER USE PUMP CARE

#### **GUMMING**

Gumming or corrosion inside the pump can be prevented by thoroughly flushing the pump with water or a liquid that will neutralize the liquid pumped. For many liquids, a solution of 1 gallon [3.785 liter] of ammonia mixed with 6 gallons [2.271 liters] of water may be used as a flushing solution. If the pump has been used for liquid fertilizer or similar liquids, it should be flushed after each use.

#### **CORROSION PREVENTION**

To prevent corrosion, Hypro recommends:

- Flush the pump as described in Gumming.
- Flush the pump with a 50-50 solution of a permanent-type automotive antifreeze containing a rust inhibitor and water; then plug the pump ports to prevent air from getting into the pump.

- Cleaning and rust protection should be performed whenever the pump will be stored for more than two to three days.

#### **DO NOT:**

- Do not use a screwdriver or hammer to force the pump apart. Follow the Repair Instructions in Hypro Form L-0100R.
- Do not run the pump dry. Doing so may damage the roller and seals.
- Do not pump sandy or gritty liquids. Avoid pumping solutions containing abrasive material.
- Do not pump hot liquids (over 140° F. [59.9° C]).
- Do not pump copper sulphate or corrosive acids with cast iron, Ni-Resist or XL Series pumps. Roundup™ type herbicides are only compatible with XL Series pumps.

## Performance

Water						
	4001N-EH AND 4001XL-EH			4001N-E2H AND 4001N-E2H		
Volts	PSI [Bar]	AMPS	GPM [LPM]	PSI [Bar]	AMPS	GPM [LPM]
12 (Battery) Engine Off	0 [0.0]	14.8	9.4 [35.6]	0 [0.0]	10.9	8.0 [30.3]
	5 [0.3]	16.4	9.0 [34.1]	5 [0.3]	11.6	7.7 [29.2]
	10 [0.7]	18	8.6 [32.6]	10 [0.7]	13.3	7.3 [27.6]
	15 [1.0]	20.1	8.1 [30.7]	15 [1.0]	15.1	6.9 [26.1]
	20 [1.4]	23.1	7.5 [28.4]	20 [1.4]	17.5	6.5 [24.6]
	25 [1.7]	25.3	6.9 [26.1]	25 [1.7]	20.2	6.1 [23.1]
	30 [2.1]**	28.5**	6.1 [23.1]**	30 [2.1]**	22	5.8 [22.0]
	35 [2.4]**	30.3**	5.8 [22.0]**	35 [2.4]**	24.4	5.2 [19.7]

Water						
	4001N-EH AND 4001XL-EH			4001N-E2H AND 4001N-E2H		
Volts	PSI [Bar]	AMPS	GPM [LPM]	PSI [Bar]	AMPS	GPM [LPM]
13.5 (Alternat or) Engine Running	0 [0.0]	17.1	10.4 [39.4]	0 [0.0]	12.2	9.3 [35.2]
	5 [0.3]	17.45	10.3 [39.0]	5 [0.3]	13.3	9.0 [34.1]
	10 [0.7]	19	9.9 [37.5]	10 [0.7]	14.3	8.6 [32.6]
	15 [1.0]	21.5	9.4 [35.6]	15 [1.0]	16	8.3 [31.4]
	20 [1.4]	23.8	8.9 [33.7]	20 [1.4]	17.6	8.0 [30.3]
	25 [1.7]**	26.8**	8.4 [31.8]**	25 [1.7]**	19.9	7.7 [29.2]
	30 [2.1]**	29.6**	7.8 [29.5]**	30 [2.1]**	22.2	7.3 [27.6]

Water						
	4101XL-EH AND 4101N-EH			4101XL-E2H AND 4101N-E2H		
Volts	PSI [Bar]	AMPS	GPM [LPM]	PSI [Bar]	AMPS	GPM [LPM]
12 (Battery) Engine Off	0 [0.0]	9.8	5.7 [21.6]	0 [0.0]	9.2	5.3 [20.1]
	5 [0.3]	11.3	5.5 [20.8]	10 [0.7]	10.4	4.5 [17.0]
	10 [0.7]	12.3	5.1 [19.3]	20 [1.4]	13.5	4.0 [15.1]
	15 [1.0]	13.6	4.8 [18.2]	30 [2.0]	15.8	3.6 [13.6]
	20 [1.4]	15.1	4.5 [17.0]	40 [2.8]	19.8	3.2 [12.1]
	25 [1.7]	16.7	4.2 [15.9]	50 [3.5]	23.4	2.8 [10.6]
	30 [2.1]	18.5	4.0 [15.1]	60 [4.1]	26.7	2.3 [8.7]
	35 [2.4]	20.3	3.7 [14.0]	70 [4.8]	30.2	1.9 [7.2]
	40 [2.8]	21.5	3.4 [12.9]	80 [5.5]	31.8	1.4 [5.3]
	45 [3.1]	23.5	3.2 [12.1]	90 [6.2]*	37*	0.9 [3.4]*
	50 [3.5]	24.8	2.8 [10.6]	100 [6.9]*	38.8*	0.5 [1.9]*

Water						
	4101XL-EH AND 4101N-EH			4101XL-E2H AND 4101N-E2H		
Volts	PSI [Bar]	AMPS	GPM [LPM]	PSI [Bar]	AMPS	GPM [LPM]
13.5 (Alternat or) Engine Running	0 [0.0]	11.1	6.6 [25.0]	0 [0.0]	9.8	5.7 [21.6]
	5 [0.3]	12.1	6.3 [23.8]	10 [0.7]	11.7	5.3 [20.1]
	10 [0.7]	13.3	6.0 [22.7]	20 [1.4]	13.8	4.8 [18.2]
	15 [1.0]	14.6	5.6 [21.2]	30 [2.0]	17	4.5 [17.0]
	20 [1.4]	16	5.3 [20.1]	40 [2.8]	19.8	4.0 [15.1]
	25 [1.7]	17.4	5.1 [19.3]	50 [3.5]	23	3.7 [14.0]
	30 [2.1]	19.2	4.9 [18.5]	60 [4.1]	26	3.3 [12.5]
	35 [2.4]	21.1	4.6 [17.4]	70 [4.8]	28.3	3.0 [11.4]
	40 [2.8]	22.9	4.4 [16.7]	80 [5.5]	31.3	2.7 [10.2]
	45 [3.1]	24.3	4.2 [15.9]	90 [6.2]*	34.6*	2.2 [8.3]*
	50 [3.5]	25.8	3.9 [14.8]	100 [6.9]*	38.3*	1.8 [6.8]*

\*Denotes product has a 50% duty cycle (30 minutes on, 30 minutes off) at the given rating.

\*\*Denotes product has a 66% duty cycle (40 minutes on, 20 minutes off) at the given rating.

# WIRING SCHEMATIC LDS-333 WITH OPTIONAL LOW PRESSURE SWITCH

## OPTIONAL EQUIPMENT

05037656 Switch, Low Pressure, Hydraulic

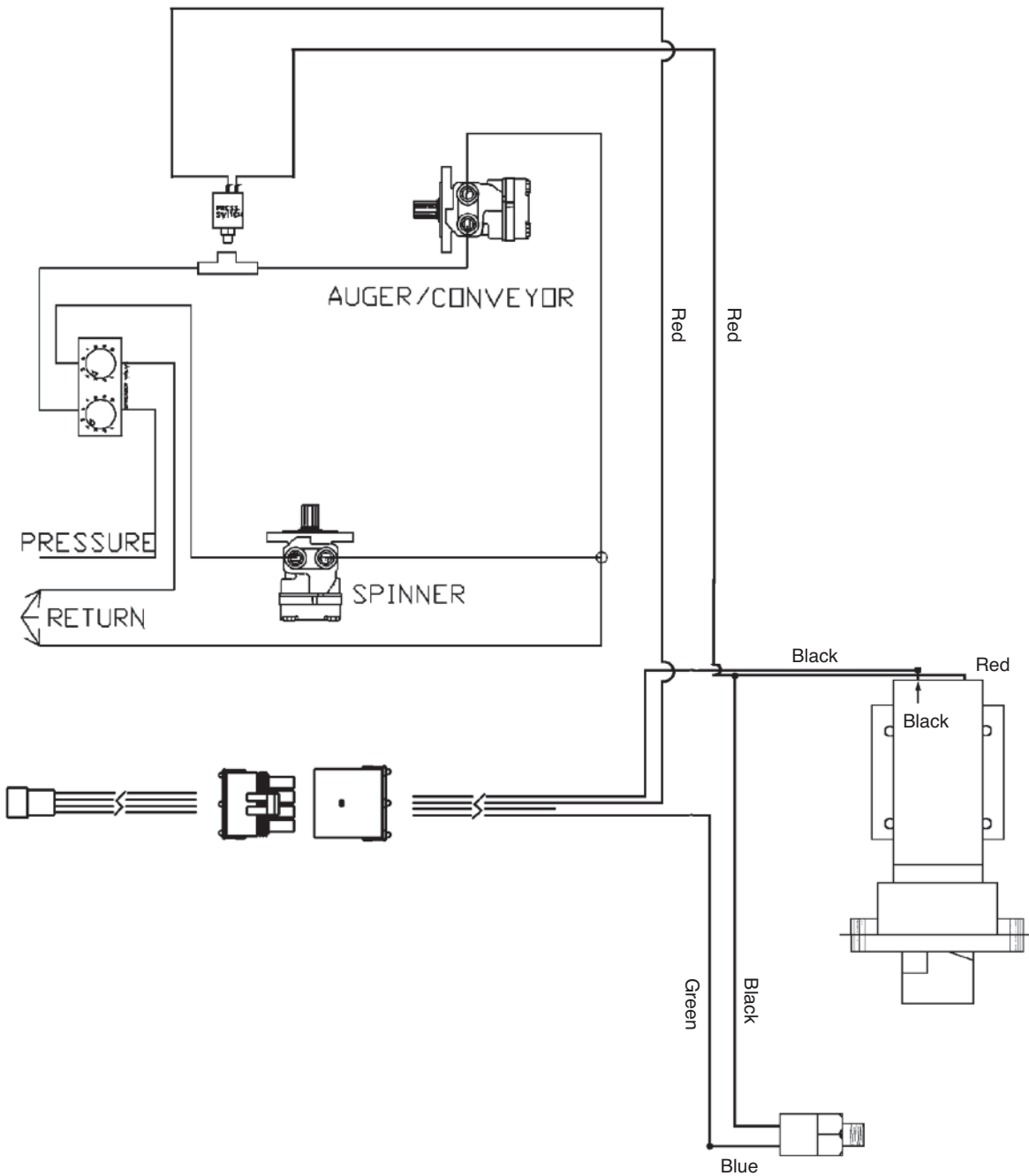



<b>SWP-</b>	05051883
<b>Task:</b>	Installation, Operation, Maintenance
<b>Product:</b>	LDS-333 Pre-Wet System
<b>Application:</b>	Kits 00016818, 00091737, 00091760
<b>Reference:</b>	Drawings 00016818, 00091737, 00091760



**Standard Work Procedure**

**Optional Low-Hydraulic Pressure Switch 05037656**



**Optional Low-Level Switch for Pre-Wet Liquid Tank**

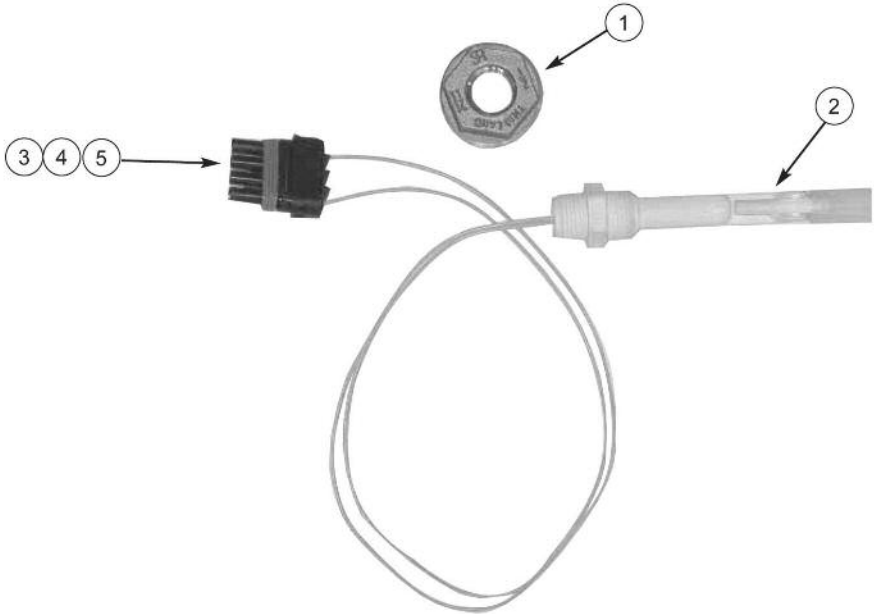

LOW LEVEL SENSOR			
Item	Qty	Part Number	Description
1	1	05037339	Bushing, Reducer, Brass, 1/4" MNPT x 1/2" FNPT
2	1	05041150	Switch, Low Level Sensor
3	1	05041384	Connector, Weather Pack, 4 Terminal, Shroud Half
4	2	05041355	Terminal, Female, F/16-14 gauge, wire
5	2	05041386	Seal, Terminal Cavity

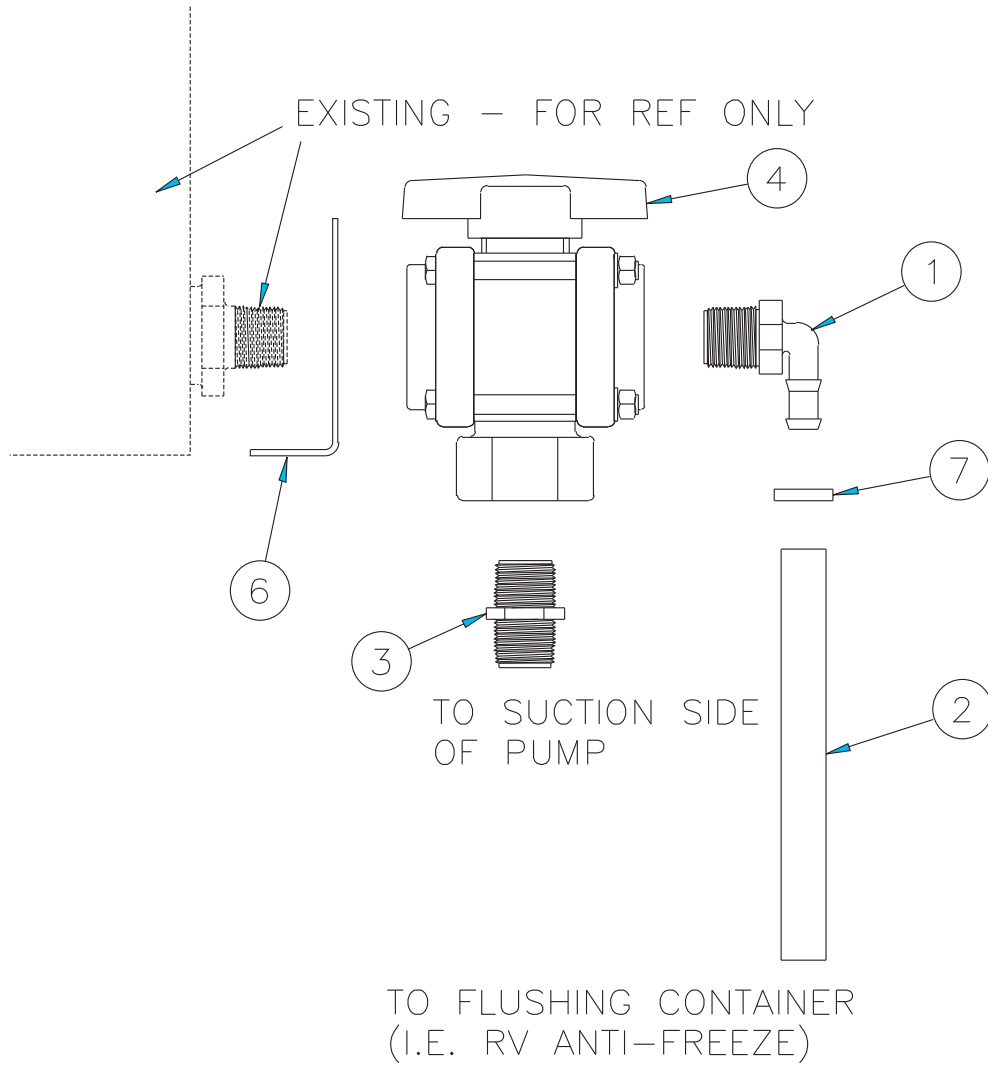

### 05050319 FLUSH KIT, 12VDC & HYDRUALIC

Item	Qty	Part Number	Description
1	1	05037303	HOSE BARB, .5 X .75 MNPT, POLY, 90°
2	3 FT	05037307	HOSE, .5, BLACK, EPDM, 150 PSI
3	1	05037355	NIPPLE, .75 NPT, SHORT, POLY
4	1	05037363	VALVE, 3 WAY BALL TYPE, .75 FNPT
5	1	05037300	CLAMP, HOSE, 1 SST
6	1	00050989	BRACKET, MOUNTING, VALVE, 2" BALL
7	1	05037281	CLAMP, HOSE, .75" SST
8	1	05051395	CARDBOARD BOX

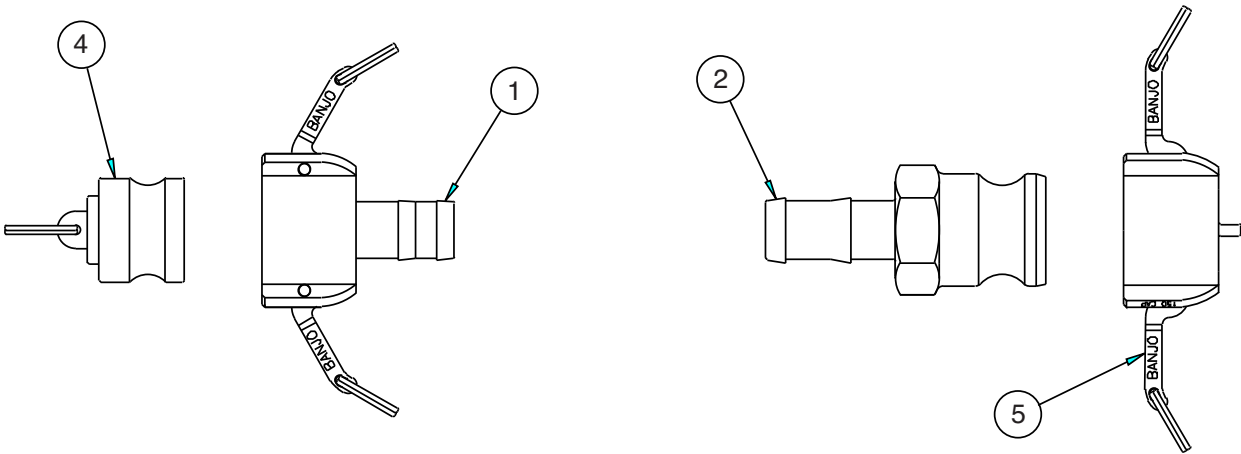

00020043 QUICK DISCONNECT KIT			
Item	Qty	Part Number	Description
1	1	05037637	COUPLER, POLY, CAM, .75" FEMALE CO
2	1	05037900	COUPLER, POLY, CAM, .75" MALE X .5" HOSE
3	2	05037281	CLAMP, HOSE, .75 SST
4	1	05038313	PLUG, POLY, CAM
5	1	05038312	CAP, POLY, CAM

## HOW TO ORDER PARTS

To order or inquire about replacement parts, please contact the **distributor** or **store** that the product was purchased through. To speed the information flow, please have the following information ready:

- Model Number
- Serial Number
- Part Number and/or description as per the parts manual
- Quantity needed

For further information about **Monroe Truck Equipment** replacement parts, please call 800-880-0109 and ask for **Snow & Ice Parts Sales**.

## RETURN POLICY

Merchandise returned to **Monroe Truck Equipment** must have a Warranty Service Request (WSR) form filled out completely and signed by authorized personnel. To get your WSR form, call 800-880-0109. For whole goods ask for **Snow & Ice Sales**. For replacement parts, ask for **Snow & Ice Parts Sales**. All returned items are subject to a 15% restocking fee and must be sent freight prepaid!

## MONROE TRUCK EQUIPMENT, INC. WARRANTY SNOW & ICE CONTROL PRODUCTS

**Monroe Truck Equipment, Inc.** warrants to the original purchaser, that if any part of the product proves to be defective in workmanship or material within **ONE YEAR** of the original installation, and is returned to us within 30 days of the discovered defect, we will (at our option) repair or replace the defective part. This warranty does not apply to damage resulting from misuse, neglect, accident, improper installation, normal wear items or lack of maintenance. This warranty is exclusive and supersedes all other warranties, whether expressed or implied. **Monroe Truck Equipment, Inc.** neither assumes, nor authorizes anyone to assume for it, any other obligation or liability in connection with this warranty and will not be liable for consequential damages.

All engines, pumps, motors, cylinders and valves are warranted by their manufacturer and not by **Monroe Truck Equipment, Inc.**. The manufacturer's warranty will apply to these parts. Electrical and hydraulic components are not to be disassembled without the express written permission of Monroe Truck Equipment. Use of replacement parts other than original equipment voids this warranty.

All defective parts returned must be accompanied by the model number, serial number, date installed, date of defect, description of defect, and the name of the distributor from whom it was purchased. All warranty claims must have prior written approval from **Monroe Truck Equipment, Inc.**

***Please return the warranty registration card that accompanies this manual to confirm receipt of this parts catalog and acknowledge the information contained within. Failure to return the attached card may result in a voided warranty.***



**1051 West 7<sup>th</sup> Street  
 Monroe, WI 53566  
 608-328-8127 ~ Fax: 608-328-4278**

## **Warranty Policy Uninstalled Parts and Equipment Provided by Monroe Truck Equipment**

Monroe Truck Equipment will provide the following limited warranty for a period of one year to the original purchaser of all uninstalled goods provided by Monroe Truck Equipment:

**LIMITED WARRANTY:** All goods provided by Monroe Truck Equipment (MTE) will be free from defects in material and workmanship for a period of one year from the date of purchase by the original purchaser. This limited warranty shall be the sole and exclusive remedy for any such product found to be defective. This limited warranty supercedes all previous warranties and is exclusive and in lieu of all other warranties, whether expressed or implied.

This limited warranty applies only to parts or accessories manufactured by MTE and/or provided by same. Except with respect to title, this limited warranty does not pertain to parts or accessories not manufactured and/or provided by MTE, regardless of whether such parts or accessories were selected and/or recommended by MTE. MTE will, as a service to the buyer, pass on any warranties received from the original manufacturer of MTE provided parts and/or accessories.

MTE will not under any circumstances be liable for any incidental or consequential damages whether in tort, contract, or otherwise, for any bodily injury, death, property damage, loss of use, or loss of income resulting from or in any way arising out of any goods provided by MTE, or their sale, use, or manufacture.

Any warranty claim deemed to be arising from the result of misuse, abuse, neglect, accident, improper installation, lack of maintenance, act of war (whether declared or otherwise), or act of God will be denied. Any repair or modification by the buyer or any third party, without the prior written consent of MTE, will void any possible warranty compensation. Any damage deemed to be the result of abnormal operation will not be compensated by this warranty.

Normal or special maintenance items such as fuels, fluids, tires, belts, hoses, filters, air cleaners, light bulbs, and any other items subject to normal wear and tear that are supplied in connection with goods provided by MTE are not allowed under this warranty.

All engines, pumps, cylinders, valves, and motors are warranted by their manufacturer and not by Monroe Truck Equipment. The manufacturer's warranty will apply to these parts. Electrical and hydraulic components are not to be disassembled without the express written consent of MTE. Any disassembly of MTE provided components without prior authorization will void the applicable warranty.

Monroe Truck Equipment shall be the sole and final determining authority as it applies to the administration of this warranty policy. Purchaser acknowledges receipt of Monroe Truck Equipment Warranty Policy and agrees to be bound by same.



**GLOBAL SOLUTIONS**  
 ARMORED VEHICLES ~ SPORT TRUCK CONVERSIONS  
 MUNICIPAL SNOW & ICE CONTROL ~ FIRE APPARATUS  
 PICKUP TRUCK ACCESSORIES ~ TRUCK EQUIPMENT/MODIFICATIONS





1051 West 7<sup>th</sup> Street  
Monroe, WI 53566  
608-328-8127 ~ Fax: 608-328-4278

Any and all warranty claims must be forwarded to MTE within 10 days of defect discovery. A copy of the original Monroe Truck Equipment invoice as well as the manufacturer's model number, serial number, and date of installation must accompany all correspondence regarding said claims. MTE will, at their option, choose whether to repair or replace the defective part unless otherwise specified by the original manufacturer of said part.

### **Procedures for Warranty Claims Notification**

For submission of any warranty claim please contact Monroe Truck Equipment – Warranty Department at 800-356-8134

The following documentation will be needed when you call for initial warranty authorization:

1. A copy of the original MTE invoice.
2. Make, Model, and VIN or Serial Number of the equipment involved.
3. Part number and serial number of the part in question.
4. A complete description of the problem.

The following must accompany any claim submitted to Monroe Truck Equipment:

1. Documented photographs of any physical damage.
2. Inspection notes by MTE personnel or MTE authorized 3<sup>rd</sup> party.
3. Authorization number issued by Monroe Truck Equipment – Warranty Department.

**Defective parts must be returned to Monroe Truck Equipment (freight prepaid) within 30 days of issuance of Authorization Number.**

**Monroe Truck Equipment reserves the right to void any warranty for failure to comply with Monroe Truck Equipment Warranty Policy.**

**This policy is effective October 11, 2012**





