



# Tailgate Spreaders MS966 - TS

## Service and Parts Manual



### **Monroe Snow & Ice Control**

*A Division of Monroe Truck Equipment*

1051 W. 7th Street

Monroe, WI 53566

Phone: 608-328-8127

Fax: 608-329-8488

Website: [www.monroetruck.com](http://www.monroetruck.com)

Email: [snowandicecontrol@monroetruck.com](mailto:snowandicecontrol@monroetruck.com)

**05090087-9**  
**3/25/2014**

# TABLE OF CONTENTS

<b>Safety Decal Location</b>	<b>Page 2</b>
<b>Safety Instructions</b>	<b>Page 3</b>
<b>General Information</b>	<b>Page 4</b>
<b>Maintenance Instructions</b>	<b>Page 5-7</b>
<b>Installation Instructions</b>	<b>Page 8-13</b>
<b>Hydraulic Troubleshooting Chart</b>	<b>Page 14-16</b>
<b>Operating Instructions</b>	<b>Page 17</b>
<b>Replacement Parts</b>	<b>Page 18-58</b>
<b>Discharge Rate Chart</b>	<b>Page 59-61</b>
<b>How to Order Parts</b>	<b>Page 62</b>
<b>Return Policy</b>	<b>Page 62</b>
<b>Warranty Policy</b>	<b>Page 63-65</b>

# SAFETY DECAL LOCATION

Should you ever need replacement decals or parts/maintenance manuals, simply contact MTE and we will supply you with them FREE OF CHARGE. See [page 33](#) for safety decal replacement part numbers.

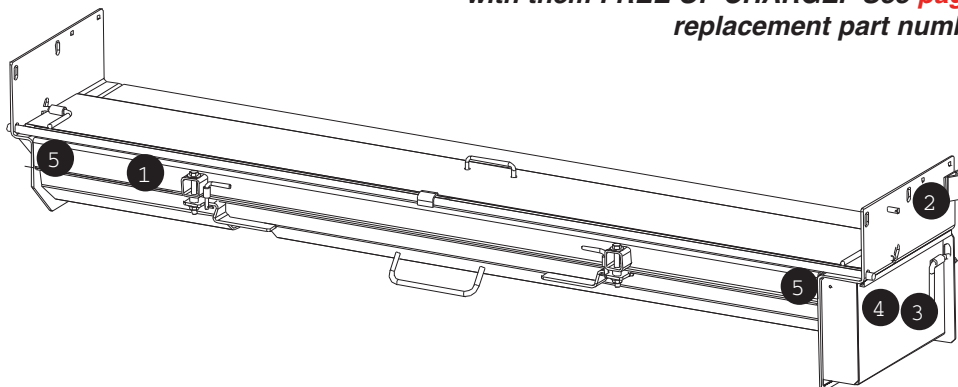

**1**



**! WARNING**

Turning spinners throw material. Stay clear & wear eye protection while spinner is turning. Failure to heed will result in serious injury

IF DEFACED - ORDER PART NO. 05051402

**2**

**! CAUTION**

1. Keep all guards/shields in place.
2. Make certain everyone is clear of machine before starting engine or operation.
3. Keep hands, feet and clothing away from power driven parts.
4. Disengage PTO, shut off hydraulic valve and set parking brake before leaving operator's position. Make sure all movement has stopped before servicing or unclogging machine.
5. Make sure machine is solidly supported when it is being mounted, dismantled or stored.
6. Use flashing lights when operating machine.

IF DEFACED - ORDER PART NO. 05051404

**3**



**! WARNING**

Moving parts can crush and dismember. Do not operate with shield removed. Keep hands clear.

IF DEFACED - ORDER PART NO. 05051403

*Used only on the Chain Drive Units*

**4**

**! DANGER**

Keep all guards/shields in place. Moving parts can crush and dismember.

IF DEFACED - ORDER PART NO. 05052310

*Used only on the Chain Drive Units*

**5**



**! DANGER**

Turning augers can crush and dismember. Turn engine off before servicing.

IF DEFACED - ORDER PART NO. 05051401

## SAFETY DECAL SIGNAL WORDS

 **DANGER**

DANGER (*Red*) indicates an imminently hazardous situation which, if not avoided, will result in death or serious injury.

 **WARNING**

WARNING (*Orange*) indicates a potentially hazardous situation which, if not avoided, could result in death or serious injury.

 **CAUTION**

CAUTION (*Yellow*) indicates a potentially hazardous situation which, if not avoided, may result in minor or moderate injury.

 **CAUTION**

CAUTION (*Yellow*) used without the safety risk alert symbol indicates a potentially hazardous situation which, if not avoided, may result in property damage.

## SAFETY INSTRUCTIONS

- Read all installation, safety and maintenance instructions completely before operating this equipment
- Keep all personnel clear of moving parts while equipment is being operated.
- Do not operate Tailgate Spreader in need of maintenance! Repair immediately!
- While operating this equipment, use common sense, use caution, be alert and be safety-conscious.
- Do not work on the spreader unless it is solidly supported and the truck engine is off!
- Truck engine and hydraulic system is to be completely shut down prior to any maintenance or repairs.
- Wear close fitting clothing and safety equipment appropriate to the job.
- Read and understand the following warning, danger and caution decals attached to this spreader. (*For locations of decals, see page 2*)
- All guards must be installed during operation.

## GENERAL INFORMATION

- The Monroe Tailgate Spreader is designed to handle a variety of granular materials including dry sand, salt, cinders and stone chips. It is to be rigidly mounted to a truck dump body just below the tailgate. The required brackets are provided.
- All references to right or left pertain to the spreader as viewed from the rear of the truck, looking in the direction of travel.
- The spreader requires 15 G.P.M. of oil at maximum operating speeds. The relief valve is set at 1500 PSI.
- Delivery of replacement parts is subject to our sales delivery terms.
- Use only **Monroe Truck Equipment** O.E.M. replacement parts. Failure to do so will void warranty.
- Replacement parts listed in this manual reflect our most common tailgate spreader items. If you do not find the part you require, please call your distributor.
- **Monroe Truck Equipment** reserves the right to make revisions or alterations to this parts manual.

 **CAUTION:** Be sure control valve and truck engine are “Off” and keys removed from ignition before doing any maintenance work.

- The cover plate may be laid flat over the trough, allowing the tailgate to open from the top or bottom for normal dumping.
- Spread pattern is adjustable by loosening two bolts and sliding the spinner right or left under the trough opening.
- The spinner is readily removable by disconnecting hoses, removing the lynch pin and moving the spinner a few inches to the right.
- The chain tightener is easily adjusted by loosening two bolts, pulling and holding the chain tight and retightening the bolts.
- Obstructions in the spreader may be removed by lowering the dump body, dropping the trough bottom and laying the cover down to the rear. This allows easy access to remove obstructions.

# MAINTENANCE INSTRUCTIONS

Due to the nature of use and environment this spreader is operating in, damage and wear may occur at any time. Therefore, **Monroe Truck Equipment** recommends the end user establish and follow a daily inspection routine before using this spreader. Failure to inspect equipment on a daily basis may seriously affect safety and/or efficiency.

## **In Season:**

- Check chain, sprockets, bearings, wear items, bolts and nuts. Replace all worn parts. Tighten chain and re-torque bolts and nuts as needed before use. (See Torque Chart on page 6)
- Check all hydraulic fittings for tightness and/or damage on a regular basis.
- Lubricate chain and all grease fittings as recommended. (See Lubrication Chart, Page 7)
- Check gearbox oil levels periodically, especially before first use of season. (See gearbox chart page 7)

## **Off Season:**

- Use care when disconnecting hydraulic lines to assure that no dirt or foreign objects enter the hydraulic system.
- Use caps to cover hydraulic hose fittings and insert plugs in hydraulic ports when storing.
- Thoroughly clean, lubricate and repaint (if necessary) prior to storage.
- Check mounting bolts for wear and/or damaged threads and replace before next season.



## **DANGER**

### **AVOID HIGH-PRESSURE FLUIDS**



Escaping fluid under pressure can penetrate the skin causing serious injury.

Avoid the hazard by relieving pressure before disconnecting hydraulic or other lines. Tighten all connections before applying pressure.

Search for leaks with a piece of cardboard. Protect hands and body from high pressure fluids.

If an accident occurs, see a doctor immediately. Any fluid injected into the skin must be surgically removed within a few hours or gangrene may result.

# TORQUE CHART

SIZE	 GRADE 2	 GRADE 5	 GRADE 8
1/4-20	50 IN-LBS	75 IN-LBS	9 FT-LBS
3/8-16	15 FT-LBS	23 FT-LBS	35 FT-LBS
1/2-13	35 FT-LBS	55 FT-LBS	80 FT-LBS
5/8-11	75 FT-LBS	110 FT-LBS	170 FT-LBS
3/4-10	130 FT-LBS	200 FT-LBS	280 FT-LBS
1-8	190 FT-LBS	480 FT-LBS	680 FT-LBS
1 1/4-7	380 FT-LBS	840 FT-LBS	1,360 FT-LBS

# BEARING LUBRICATION CHART

## LUBRICATION

All bearing units are factory prelubricated and, therefore, do not require supplemental grease before service life begins. Relubrication, when administered correctly, can increase the life of a bearing substantially. We recommend the following general guidelines to maximize your bearing life:

RPM	Temperature	Environmental Condition	Interval
100 500 1,000	32°F-120°F 32°F-150°F 32°F-210°F	Clean Clean Clean	6-12 months 2-6 months 2 wks to 2 months
1,500 Any	Over 210°F 32°F-150°F	Clean Dirty	Daily to weekly Weekly to monthly
Any Any	Over 150°F Any Temp.	Dirty Very Dirty	Daily to 2 wks Daily to weekly
Any	Any Temp.	Extremely Dirty	Daily to weekly

**BEARING, 1 1/4", 2-BOLT  
PN: 05030024**

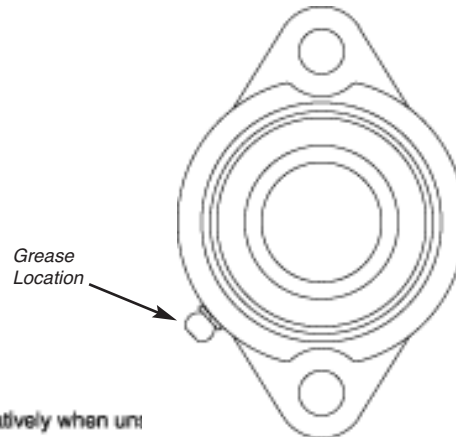

**NOTE:**

Over lubrication is a major cause of bearing failures. Please relubricate conservatively when unit bearing requirements.

When selecting a bearing lubricant, your dealer suggest any lithium-based NLGI #2 grease. For operating temperatures higher than 210°F, please consult your dealer.

## CHAIN LUBRICATION CHART

Temperature	Lubricant Viscosity
-20°F to 20°F	SAE10
20°F to 40°F	SAE20
40°F to 100°F	SAE30
100°F to 120°F	SAE40
120°F to 140°F	SAE50

**Notes:**

- **Frequency:** Lubricate chain liberally at regular weekly to monthly intervals.
- **Lubricant:** A non-detergent, petroleum based oil that is free of contaminants is recommended for use.

## GEARBOX LUBRICATION CHART

**WARNING**  
 THE OIL LEVEL MUST BE CHECKED BEFORE PLACING THE UNIT INTO OPERATION! OIL LEVEL SHOULD BE CHECKED PERIODICALLY THEREAFTER.

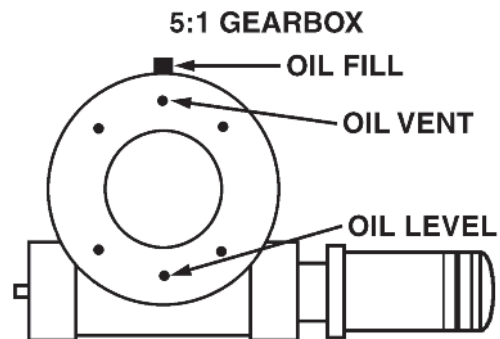



Ambient Temperature	Lubricant
-20°F to 0°F	SAE 10W/30 or 10W/40 Automotive Oil
0°F to 40°F	SAE 80 Gear Oil with Anti-Foaming Agent
40°F to 100°F	SAE 90 Gear Oil with Anti-Foaming Agent
100°F to 150°F	SAE 140 Gear Oil with Anti-Foaming Agent







<b>SWP-</b>	00245
<b>Task:</b>	Clean out spreader trough
<b>Product:</b>	Under tailgate spreader
<b>Application:</b>	All
<b>Reference:</b>	n/a



## Standard Work Procedure

<p><b>DANGER</b></p> 		<p>Crushing and dismemberment hazard. Can cause death or serious injury.</p> <p>Stay away from moving auger. Never work on the spreader with the auger turning.</p> <p>Shut off vehicle &amp; disable hydraulic system before accessing the spreader auger.</p> <p>Keep all covers and shields in place when the auger is turning.</p>
--	---	--



<p><b>DANGER</b></p> 		<p>Crushing and dismemberment hazard. Rotating auger can cause death or serious injury.</p> <p>Stay away from moving gears and drive chains. Never work on the spreader with the drive turning.</p> <p>Shut off vehicle &amp; disable hydraulic system before accessing the drive system.</p> <p>Keep all covers and shields in place when the drive is turning.</p>
---	---	--

<p><b>DANGER</b></p> 		<p>Crushing and dismemberment hazard. Rotating auger can cause death or serious injury.</p> <p>Do not climb into the dump bed or climb on the spreader when the auger is turning. Do not try to push granular material into the auger from inside the dump bed.</p> <p>Shut off vehicle &amp; disable hydraulic system before cleaning out the dump bed or spreader.</p>
--	---	--

<b>SWP-</b>	00245
<b>Task:</b>	Clean out spreader trough
<b>Product:</b>	Under tailgate spreader
<b>Application:</b>	All
<b>Reference:</b>	n/a



## Standard Work Procedure

<p><b>WARNING</b></p> 	 <p>Eye and facial injury hazard. Granular material can cause blindness or serious eye injury.</p> <p>Stay away from the spinner when it is turning. Never work around a turning spinner when there is granular material in the spreader.</p> <p>Wear eye and face protection when working on or around a spinner. As a minimum, wear safety glasses with side shields.</p>
---	--

<p><b>NOTE</b></p>	 <p>Never leave a vehicle with granular material in the spreader outside in freezing weather. If the material has moisture in it, the material in the spreader (and in the body) may freeze solid.</p> <p>If a spreader vehicle cannot be stored in a heated building, dump the material load and run the spreader until it is empty before parking the vehicle.</p>
--------------------	--

<b>SWP-</b>	00245
<b>Task:</b>	Clean out spreader trough
<b>Product:</b>	Under tailgate spreader
<b>Application:</b>	All
<b>Reference:</b>	n/a



## Standard Work Procedure

Look	Action	Task
------	--------	------

		<ol style="list-style-type: none"> <li>1. Stop the vehicle, shut off the hydraulic system and the engine, then remove the ignition keys so the engine cannot be restarted.</li> <li>2. If your shop has a formal lockout/tag program for powered equipment, follow all program instructions.</li> </ol>
--	--	---

		<ol style="list-style-type: none"> <li>3. Disconnect the spreader hydraulic hoses. This will insure that the auger and spinner cannot be started while the spreader is being worked on.</li> <li>4. If the spreader uses an electric drive motor, disconnect the power wiring for the motor.</li> </ol>
--	--	---

<p><b>NOTE</b></p>		<p><b>Some brands and models of spreaders have mechanical “interlocks” that require the hydraulic hoses or electrical motor wiring to be disconnected before the bottom trough cover can be opened.</b></p> <p><b>Refer to the instructions provided with the spreader for information on using the interlocks.</b></p>
--------------------	--	---

<b>SWP-</b>	00245
<b>Task:</b>	Clean out spreader trough
<b>Product:</b>	Under tailgate spreader
<b>Application:</b>	All
<b>Reference:</b>	n/a



## Standard Work Procedure

Look	Action	Task
------	--------	------

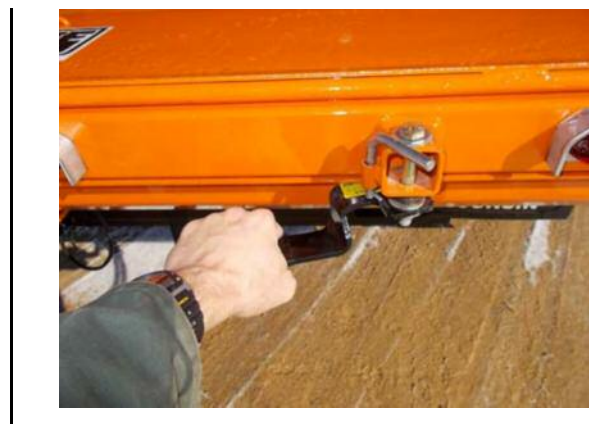

5. Lift the lock pin on one of the bottom trough cover levers and move the lever to the open position.
6. Lift the lock pin on the other bottom trough cover lever.
7. Hold the handle in the middle of the bottom trough cover and move the other lever to the open position.



8. Lower the bottom trough cover carefully to the fully open position.
9. Use a metal rod, a scraper, or a small shovel to break loose any packed or frozen material in the auger.
10. If the vehicle is inside a shop, a water hose or pressure washer may be used to loosen and remove compacted or frozen material.









11. If material is frozen solid in the spreader, open the top lid and work from the top to loosen the material. A heated pressure washer is the quickest method of getting frozen material out of the trough.
12. The vehicle can also be left overnight in a heated building to allow the material to thaw.

<b>SWP-</b>	00245
<b>Task:</b>	Clean out spreader trough
<b>Product:</b>	Under tailgate spreader
<b>Application:</b>	All
<b>Reference:</b>	n/a



## Standard Work Procedure

Look	Action	Task
		<ol style="list-style-type: none"> <li>13. When the trough is cleaned out, inspect all parts for damage related to the jammed auger. Make necessary repairs before placing the spreader back in service.</li> <li>14. Close the top lid (if it was opened).</li> <li>15. Raise the bottom cover and move the latch levers to the closed position.</li> <li>16. Make sure that the lock pins drop down to prevent the levers from opening accidentally.</li> </ol>
		<ol style="list-style-type: none"> <li>17. Clean the ends of the hydraulic quick disconnects for the auger and spinner and reconnect them.</li> <li>18. If the spreader uses an electric motor, reconnect the power wiring.</li> <li>19. If the spreader uses an interlock device, verify that the hydraulic or electric connections are reestablished when the interlock is engaged.</li> </ol>
		<ol style="list-style-type: none"> <li>20. Start the vehicle engine and the hydraulic system.</li> <li>21. Run the spreader to verify that the auger and spinner are operating normally.</li> </ol>

# SPREADER INSTALLATION INSTRUCTIONS



**CAUTION:** Follow all safety messages and precautions involved when installing or operating the tailgate spreader. It means to be **CAREFUL, ALERT** and **SAFETY CONSCIOUS!!!**

**PACKING LIST:** Check the materials received against the order and packing list to verify that all components have been received. Some hydraulic components may be shipped direct from the manufacturer. Some attaching hardware is shipped inside the spreader.

**POSITIONING SPREADER:** The spreader is to be mounted solidly on the rear of the dump body directly below the tailgate hardware as close to the body as possible.

1. Set the dump body tailgate in the horizontal position by pivoting it in the lower hinges and supporting it with the chains. Mark a line across the rear of the body at the lower surface of the tailgate. Raise the tailgate.

**DO NOT INSTALL SPREADER UNLESS SOLIDLY SUPPORTED. USE APPROPRIATE MATERIAL HANDLING EQUIPMENT TO LIFT IN PLACE.**

2. Place the spreader against the body with the auger drive on the right side. Adjust the spreader elevation until the top of the spreader trough is 1" below the line marked previously.
3. Adjust the top of the spreader trough parallel to the dump body floor and centered from side to side. (Trough top and dump body floor are not necessarily level.)
4. Verify that the trough cover and dump body tailgate can be opened and closed without interference.

**ATTACHING SPREADER: (See figure 1 on following page)** The spreader is to be attached to the dump body rub rails using the quick-detach (Q-D) hardware.

1. Align spreader Q-D bracket and body Q-D bracket on body rub rail. The body Q-D bracket should be flush with end of body.
2. Weld the body Q-D brackets or drill holes and bolt body Q-D bracket to rub rails.
3. Pin spreader Q-D bracket to the body Q-D bracket with the Q-D pin. The body Q-D bracket may require bending or shimming to align with the spreader end plate.
4. Pin the hanger bar to the spreader end plate.
5. Install the clevis pin on the support hanger and lock in place with hairpin keeper.
6. Pivot the support hanger towards the top of the rub rail. Weld clevis pin to the body in desired location. Repeat steps 4-6 for other side).
7. If irregularities in the rear of the body cause openings between the dump body and the trough lip, you may want to add a 7 gauge sealer strip welded or bolted to the lip to close these gaps.

**TAILGATE SHIELDS: (See figure 2 on the following page)** Bolt or weld the shields to the inside of the tailgate to prevent material spillage at the ends.

# SPREADER INSTALLATION INSTRUCTIONS

Figure 1

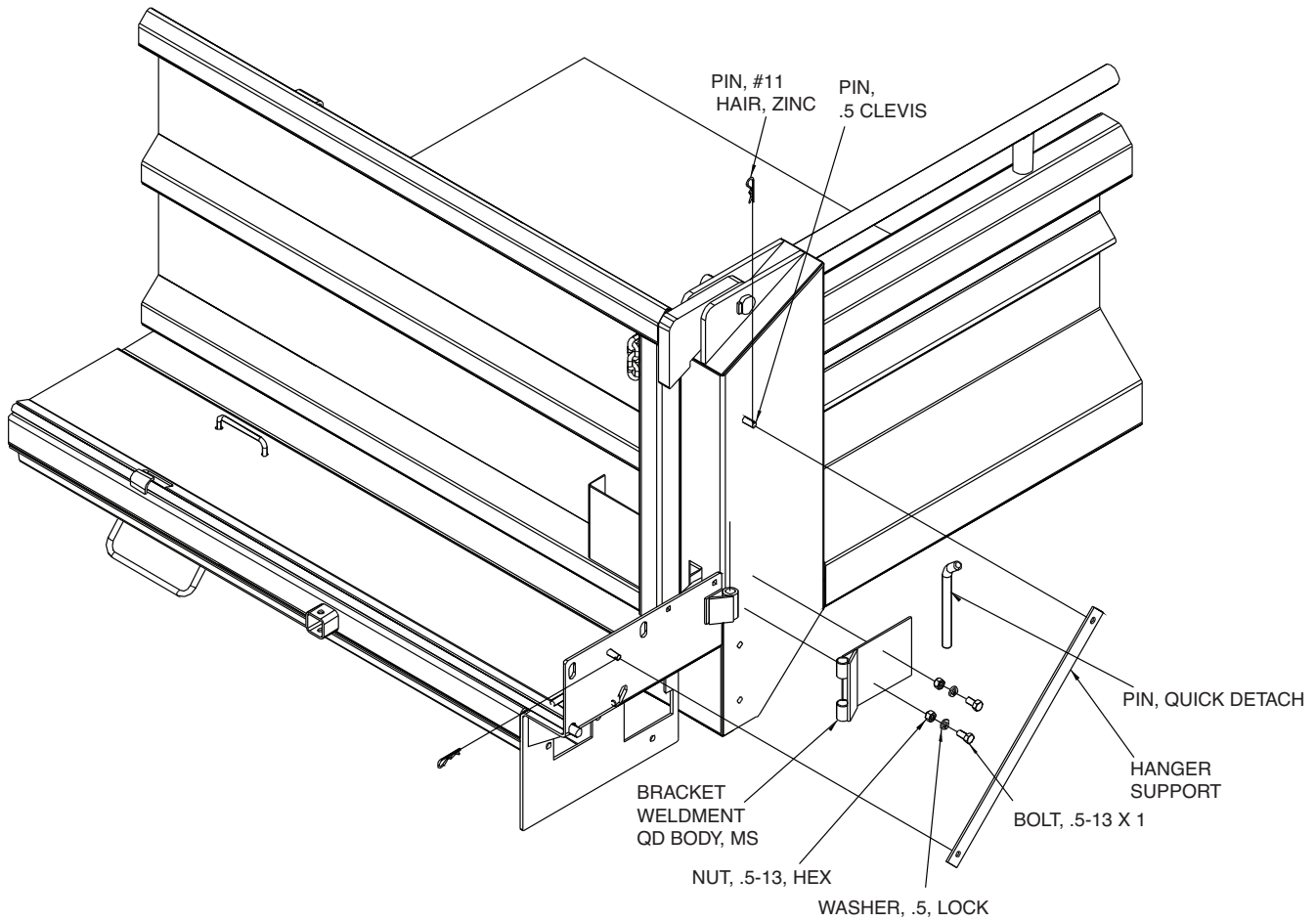
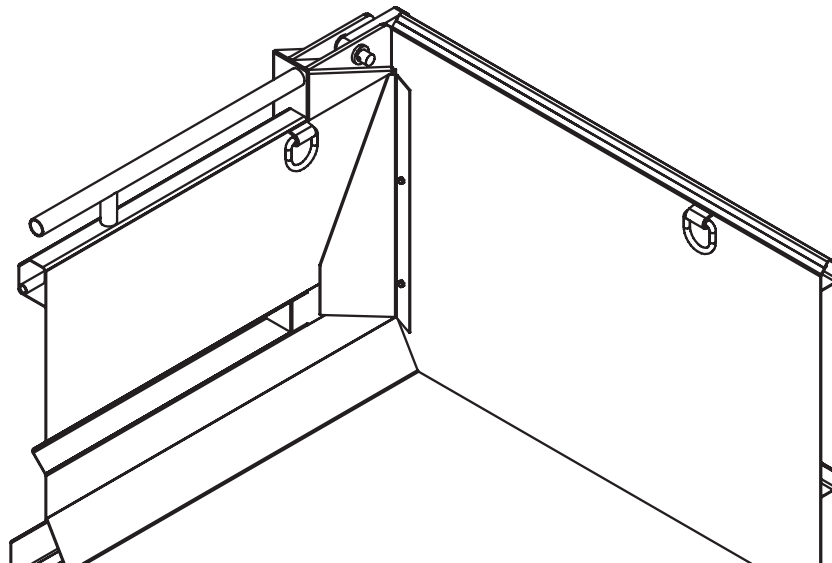

Figure 2



# STANDARD SPINNER INSTALLATION INSTRUCTIONS

**SPINNER ASSEMBLY:** The spinner is to be mounted on the spreader through by the discharge opening(s).

1. Bolt the spinner frame to the adjustment angle.
2. Mount the spinner to the trough by inserting the pins on the adjustment angle into the mounting brackets on the trough by the discharge.
3. Secure with the lynch pin.

**STABILIZER BAR: (For Non-Self Leveling Spinners Only)**

The objective of the stabilizer bar is to create a parallelogram linkage between the dump body hinge pin, stabilizer bar and spinner. This ensures that the spinner disc will stay parallel to the road surface at any dump body angle. (Reference Figure 1)

**Figure 1**

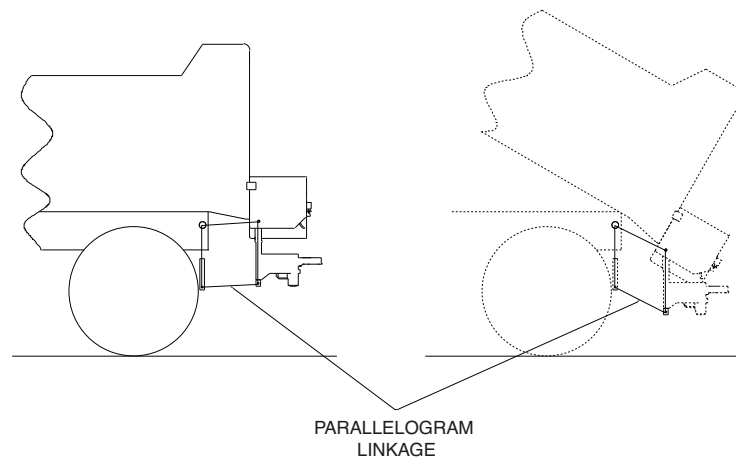

1. (Reference Figure 2) Position the stabilizer bar on chassis so that the hole is 18" directly below the dump body hinge pin and as close to being in line with the spinner as practical (within approximately 8"). Weld the stabilizer bar in place.

**NOTE:** (Reference Figure 3) A spacer block (not furnished) can be installed between the chassis frame rail and the stabilizer bar if required to locate the stabilizer bar closer to the spinner for alignment of stabilizer rods.

2. (Reference Figure 2) With the spinner mounted, position the stabilizer bracket on the bottom front of the spinner a-frame. Locate the stabilizer bracket so that the hole is in line with the stabilizer bar installed in step 1. Weld the stabilizer bracket in place.

**NOTE:** (Reference Figure 3) A mounting angle (not furnished) positioned on the bottom front of the spinner a-frame may be required to extend the stabilizer bracket for proper alignment of the stabilizer bracket hole and the stabilizer bar.

3. (Reference Figure 2) Install one each of the stabilizer rods in the stabilizer bar and the stabilizer bracket. Hold the spinner disc level and weld the rods together. Insert the hair pins through the stabilizer rods.



# STANDARD SPINNER INSTALLATION INSTRUCTIONS

Figure 2

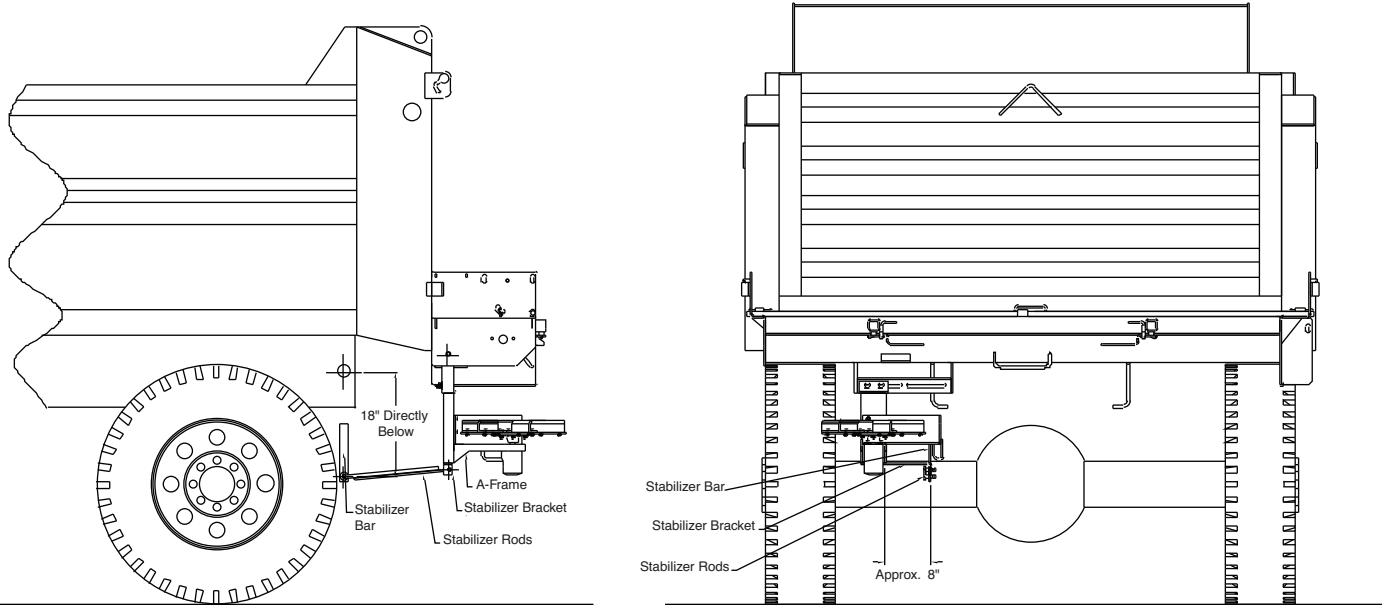
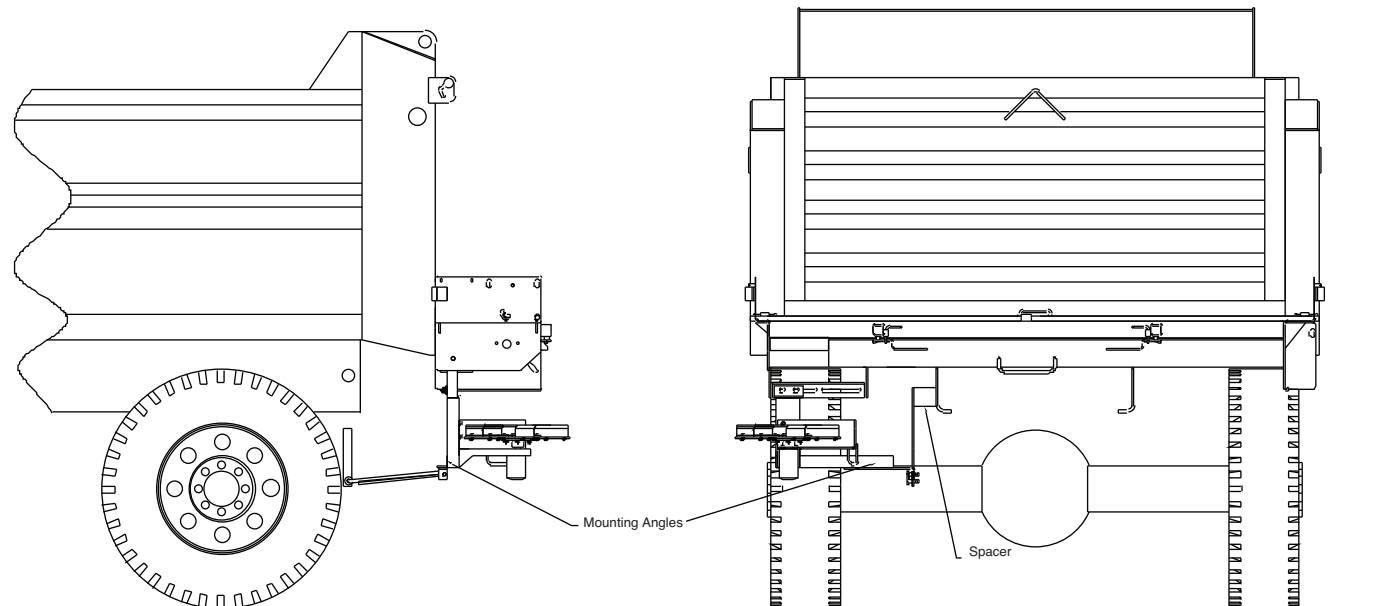

Figure 3



# CENTERLINE CHUTE INSTALLATION INSTRUCTIONS

**CL CHUTE ASSEMBLY:** The centerline chute is to be mounted on the spreader trough by the discharge opening(s).

1. Remove the hanger assembly from the spinner.
2. Bolt the chute bracket to the hanger assembly.
3. Mount the CL chute to the trough by inserting the pins on the hanger assembly into the mounting brackets on the trough by the discharge. Secure with the lynch pins.
4. Drill holes in the chute at the desired location for the cross bar. Bolt cross bar to the chute. (Chute may be trimmed to desired length.)
5. Bolt the chain to the lift slot on the spreader end plate.

**STABILIZER BAR:** (For Non-Self Leveling Chutes Only)

See spinner installation instructions. (Reference p 10-11)

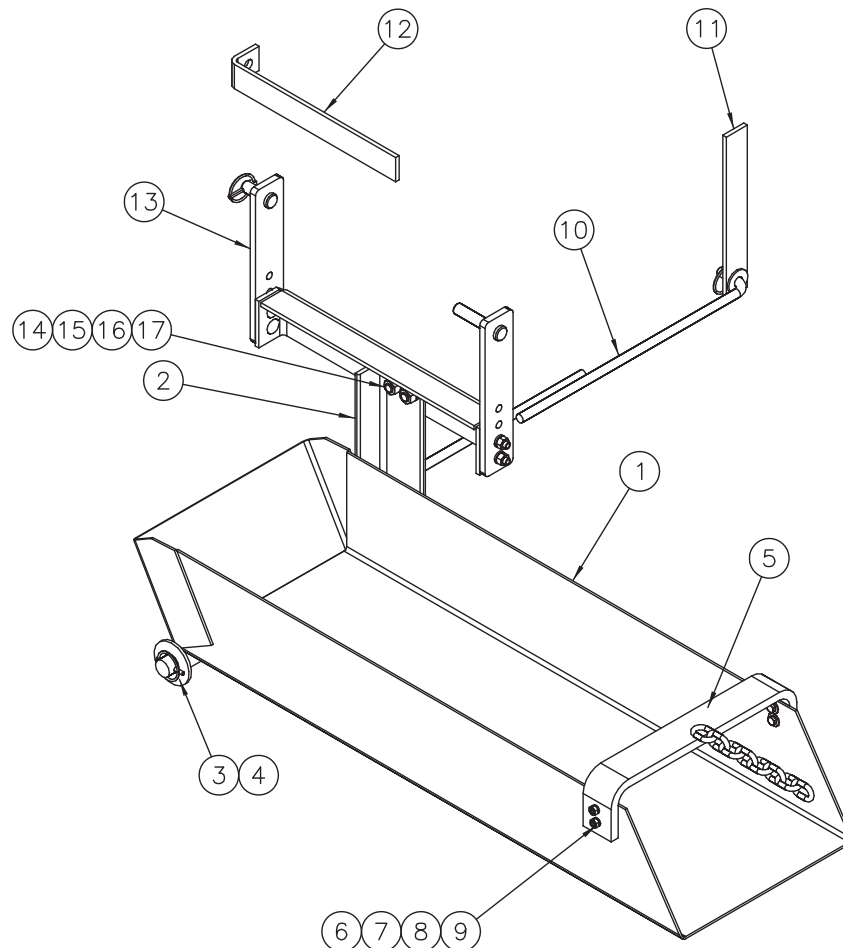

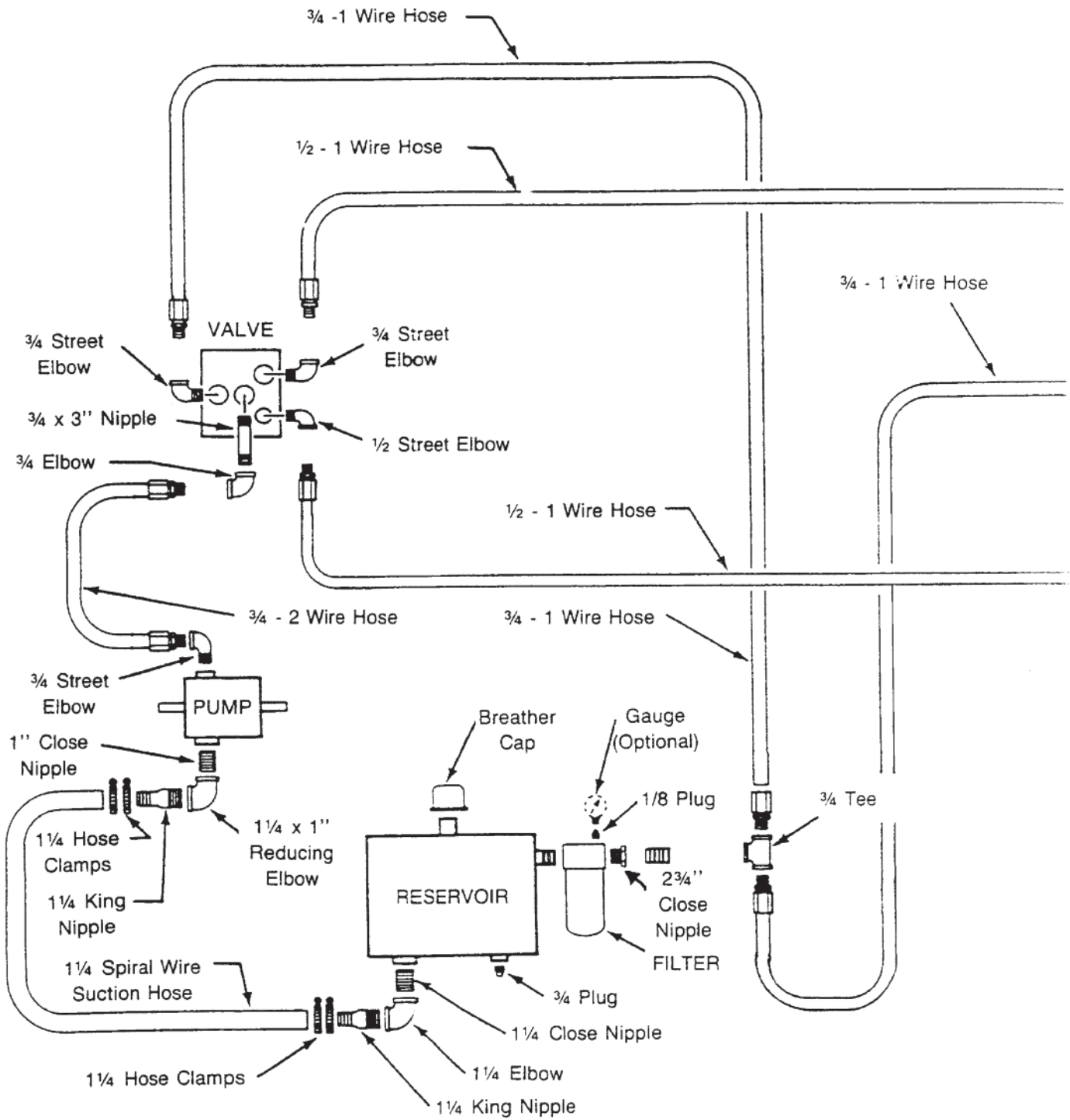

- This diagram is Monroe Truck Equipment Company's complete recommended hydraulic system.
- Standard pump, valve, tank and hose kits make up the complete system.
- This diagram may be used to install an entire system, or part of a system, depending upon kits supplied, and existing components on truck.
- Alternate proven methods and components are acceptable to suit various truck model requirements.

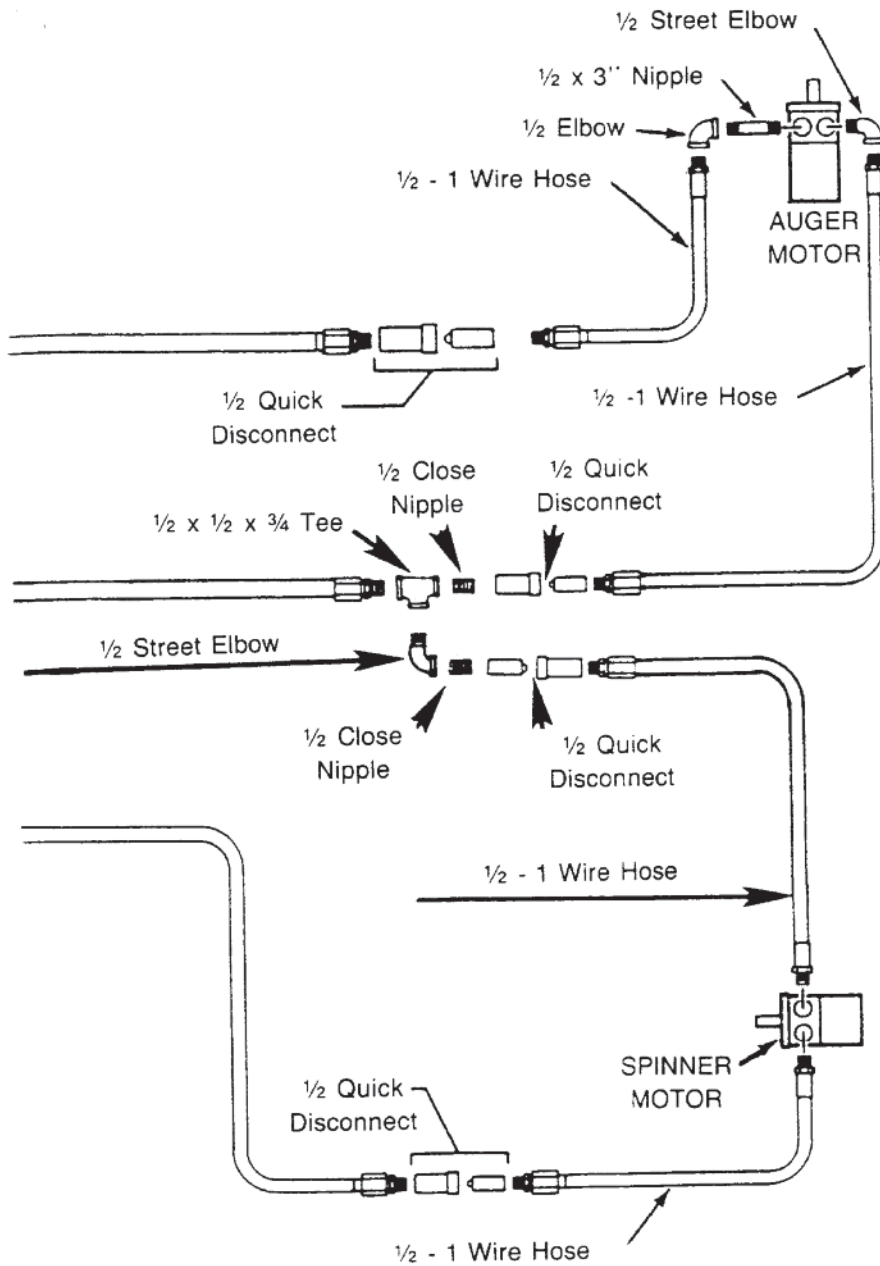

### INSTALLATION NOTES

1. Hydraulic components should be kept as clean as possible during assembly operations.
2. Galvanized pipe and pipe fittings must not be used because flaking of galvanizing material can cause damage to major hydraulic components.
3. A pipe joint sealant compatible with hydraulic oil must be applied to all NPT fittings. (Teflon tape is not recommended.)
4. Sufficient hose should be allowed for raising dump body without kinking or stretching hose.
5. Hose should be protected where severe wear may be caused by vibration or sliding movement.
6. Long runs of hose should be supported by tie wiring or clamping.
7. Pressure and return hoses, connected to spinner or auger motors, may be reversed for proper motor rotation.
8. Three hose lines to rear of truck may be installed inside truck frame, under dump body floor, and secured in place.
9. Use hose manufacturer's recommendations for fitting reusable hose ends.
10. To eliminate hose twisting, allow hose end clamp to remain loose until hose end fitting is screwed tightly in place.

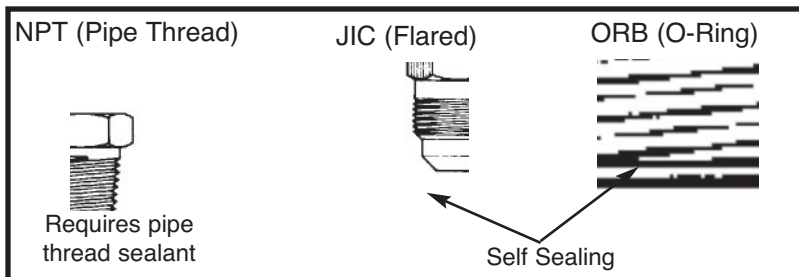

### HYDRAULIC PLUMBING DIAGRAM for SPREADERS

# HYDRAULIC TROUBLE SHOOTING CHART

## CONDITION 1

Pump cavitation recognized by excessive noise.

### CAUSE

- a. Air entering system through suction lines.
- b. Suction line kinked, twisted or too long.
- c. Inadequate size suction line.
- d. Oil too heavy.
- e. Excessive pump speed. Normal pump speed 1200 to 1500 RPM

### CORRECTION

- a. Check line from reservoir for possible leaks.
- b. Install suction line as short and straight as possible.
- c. Increase suction line size.
- d. Drain and replace with a low viscosity non-detergent oil.
- e. Pump capacity is 16 GPM at 1000 RPM. Decrease P.T.O. speed accordingly.

## CONDITION 2

Slow operation of auger and/or spinner.

### CAUSE

- a. Worn or defective pump.
- b. Worn or defective motor.
- c. Pump cavitation.
- d. Insufficient pump speed.

### CORRECTION

- a. Repair or replace pump.
- b. Repair or replace motor.
- c. Refer to pump section.
- d. Pump capacity is 16 GPM at 1000 RPM. Increase P.T.O. accordingly.

## CONDITION 3

Erratic operation of auger and/or spinner.

### CAUSE

- a. Low oil.
- b. Worn or defective motor.
- c. Dirty, worn or defective flow control valve.
- d. Plugged filter.
- e. Relief valve setting too low.
- f. Pump cavitation.
- g. Air vent on reservoir tank is blocked.

### CORRECTION

- a. Fill reservoir to a  $\frac{3}{4}$  full level.
- b. Repair or replace motor.
- c. Clean, repair or replace flow control.
- d. Replace filter element and clean filter.
- e. Adjust relief valve for 1500 PSI.
- f. Refer to pump section.
- g. Clean or replace vent cap to admit atmospheric pressure to inside of the tank.

## CONDITION 4

Auger and/or spinner will not operate.

### CAUSE

- a. Quick disconnects are dirty, damaged, or improperly connected.
- b. Hose connections wrong.
- c. Foreign material in valve compensator.

### CORRECTION

- a. Clean or replace and properly connect.
- b. Refer to illustration.
- c. Remove compensator and clean.

# OPERATING INSTRUCTIONS



## **WARNING**



THE OIL LEVEL MUST BE CHECKED BEFORE PLACING THE UNIT INTO OPERATION!  
OIL LEVEL SHOULD BE CHECKED PERIODICALLY THEREAFTER.



**CAUTION:** Make certain everyone is clear of machine before starting engine or operation.

### **INITIAL TEST RUN:**

1. The unit should be run without material to check operation.
2. Fill tank to within about 2" of the top.
3. Put the "On-Off" lever on the control valve to the "Off" position.
4. Start the engine, engage the P.T.O. or turn on the hydraulic system and allow the oil to circulate through the system.
5. Move the lever to the "On" position. If the engine lugs down, shut the valve "Off" IMMEDIATELY. This indicates the system is not properly plumbed, which must be corrected.
6. Check the spinner and auger to make sure they are turning in the right direction.
7. Check the system for leaks. Tighten hydraulic fittings as required.
8. Refill reservoir.

### **NORMAL OPERATION:**

1. Place the cover plate in its upright position and latch.
2. Open the dump body tailgate latch and adjust stop chains so that the tailgate stops just short of the spreader cover plate.
3. Adjust the spinner if necessary.
4. Engage P.T.O. Turn on the hydraulic system.
5. Raise the dump body until material slides back and charges the spreader with granular material.
6. Set the control valve knobs to desired settings.
7. Engage the spreader by moving the control valve lever to the "On" position.

# REPLACEMENT PARTS

## SPREADER, UNDER TAILGATE, MS966-TS

Item	Qty	Part Number	Description
1	1	<b>See Page 23</b>	TROUGH WELDMENT, MS966-TS
2	1	00084195-A 00084195-B	LID WELDMENT, MS      See Page 35 LID WELDMENT, SST
3	1	00054857-A 00054857-B	TROUGH BOTTOM WELDMENT,MS      See Page 24 TROUGH BOTTOM WELDMENT, SST
4	1	<b>See Page 25</b>	AUGER WELDMENT/AUGER KIT
5	2	00041644-A 00041644-B	ANTI-FLOW PLATE, MS      See Page 40 ANTI-FLOW PLATE, SST
6	2	05022035	PIN, #11
7	*	00021724-A 00021724-B	BEARING KIT, MS      See Page 41 BEARING KIT, SST
8	1	<b>See Page 26</b>	DRIVE KIT
9	1	00054882-A 00054882-B	MOUNTING KIT, MS      See Page 34 MOUNTING KIT, SST
10	1	<b>See Page 39</b>	DECAL KIT, TGT SPREADER CHAIN DRIVE DECAL KIT, TGT SPREADER GB/DD
11	1	05090095	TAG, SERIAL NUMBER
12	1	00097647-A 00097647-B	LATCH KIT, UT, MS      See Page 48 LATCH KIT, UT, SST

\* Bearing kit quantity is 2 for chain drive units and 1 for direct drive and gearbox units.

# TROUGH WELDMENT, MS966-TS

00054859-A/B TROUGH WELDMENT, MS966-TS

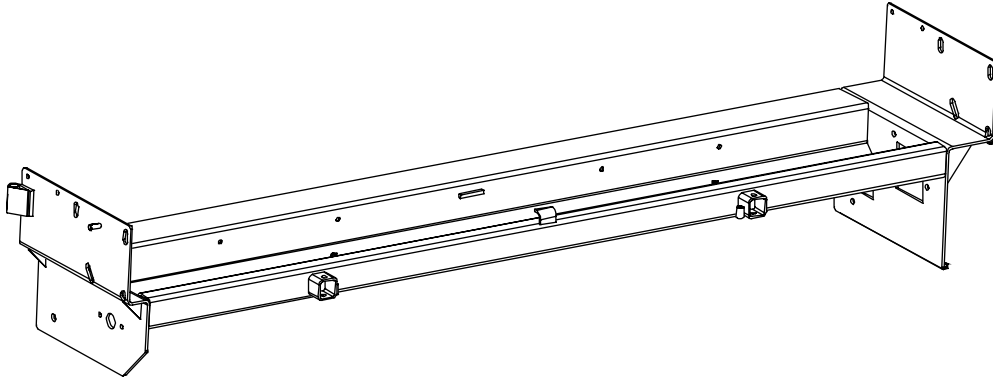

00093812-A/B TROUGH WELDMENT, MS966-TS, DD/GB

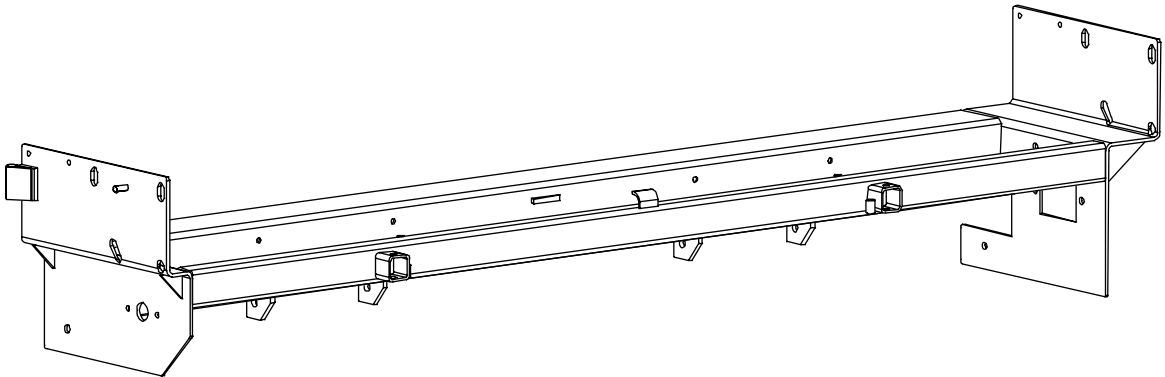



## LID WELDMENT, MS966

00084195-A/B LID WELDMENT

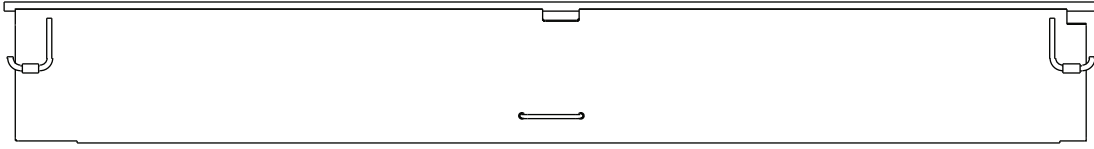

## TROUGH BOTTOM WELDMENT

00054857-A/B TROUGH BOTTOM WELDMENT, MS966-TS

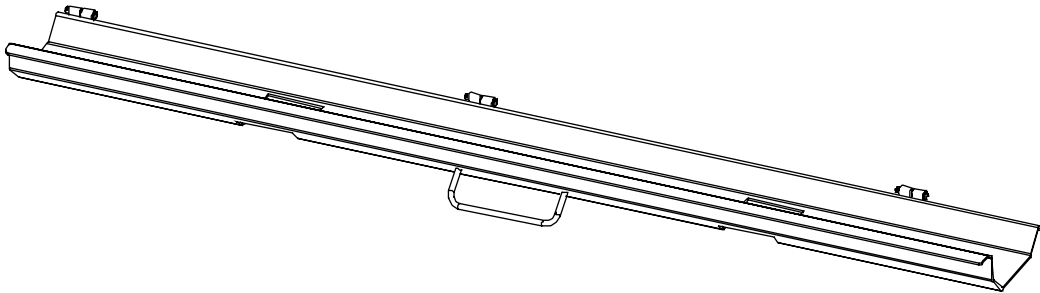

# AUGER WELDMENT/AUGER KIT

## 00021672 AUGER WELDMENT, UT, MS966-TS

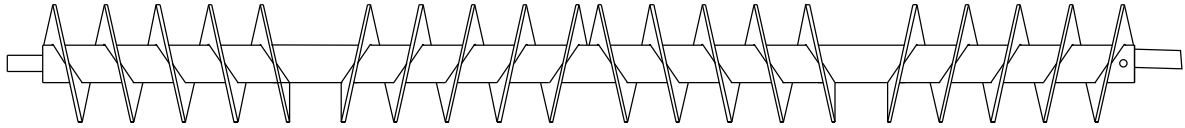

## 00021670 AUGER WELDMENT, UT, MS966-TS-GB/DD



## 00022132 AUGER KIT, UT, MS966-TS-DD

Item	Qty	Part Number	Description
1	1	00021670	AUGER WELDMENT, UT, MS966-TS-GB/DD
2	1	00021746	BUSHING, AUGER, DIRECT DRIVE
3	1	00072550	COUPLER, SHAFT, 1" X 4", SST
4	1	05010699	BOLT, .5-13 X 3.5, G8, HHCS, ZINC
5	1	05020268	NUT, .5-13, G8, HEX, ZINC
6	1	05021367	WASHER, .5, LOCK, ZINC

# DRIVE KITS, MS966/886

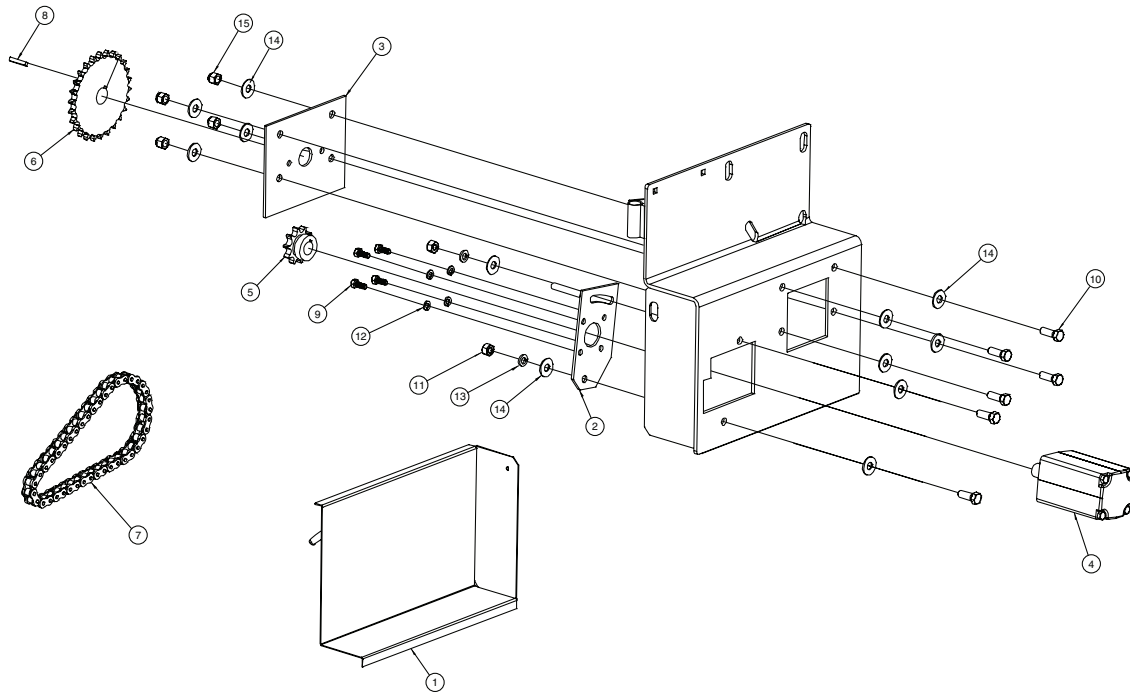

## 00058124 DRIVE KIT, MS966/886, CHAIN

Item	Qty	Part Number	Description
1	1	00021769-A 00021769-B	CHAIN COVER, RH, MS CHAIN COVER, RH, SST
2	1	00022314-A 00022314-B 00022314-C	MOUNTING PLATE WELDMENT, MS MOUNTING PLATE WELDMENT, SST MOUNTING PLATE WELDMENT, AUSST
3	1	00041089-A 00041089-B 00041089-D	ADAPTER PLATE, AUGER, MS ADAPTER PLATE, AUGER, SST ADAPTER PLATE, AUGER, AUSST
4	1	05006549	MOTOR, HYD, WHITE, 10CID, 1" SHAFT See Page 50
5	1	05033010	SPROCKET, 60B10FX1, .25" KEYWAY
6	1	05033014	SPROCKET, 60B26FX1.25, .25" KEYWAY
7	1	05036062	CHAIN ASSY, W/ CONNECTOR LINK
8	1	05050121	KEY, .25 X .25 X 1.5
9	4	05010642 05016050	BOLT, .375-16 X .875, G8, HHCS, ZINC BOLT, .375-16 X .875, G8, HHCS, SST
10	6	05017108 05017107	BOLT, .5-13 X 1.375, G8, HHCS, ZINC BOLT, .5-13 X 1.375, HHCS, SST
11	2	05020268 05020848	NUT, .5-13, G8, HEX, ZINC NUT, .5-13, HEX, SST
12	4	05021365 05021392	WASHER, .375, LOCK, ZINC WASHER, .375, LOCK, SST
13	2	05021367 05021396	WASHER, .5, LOCK, ZINC WASHER, .5, LOCK, SST
14	12	05021309 05021391	WASHER, .5, FLAT, ZINC WASHER, .5, FLAT, SST
15	4	05020847 05020908	NUT, .5-13, GC, TOPLOCK, C&W NUT, .5-13, NYLON LOCK, 316 SST

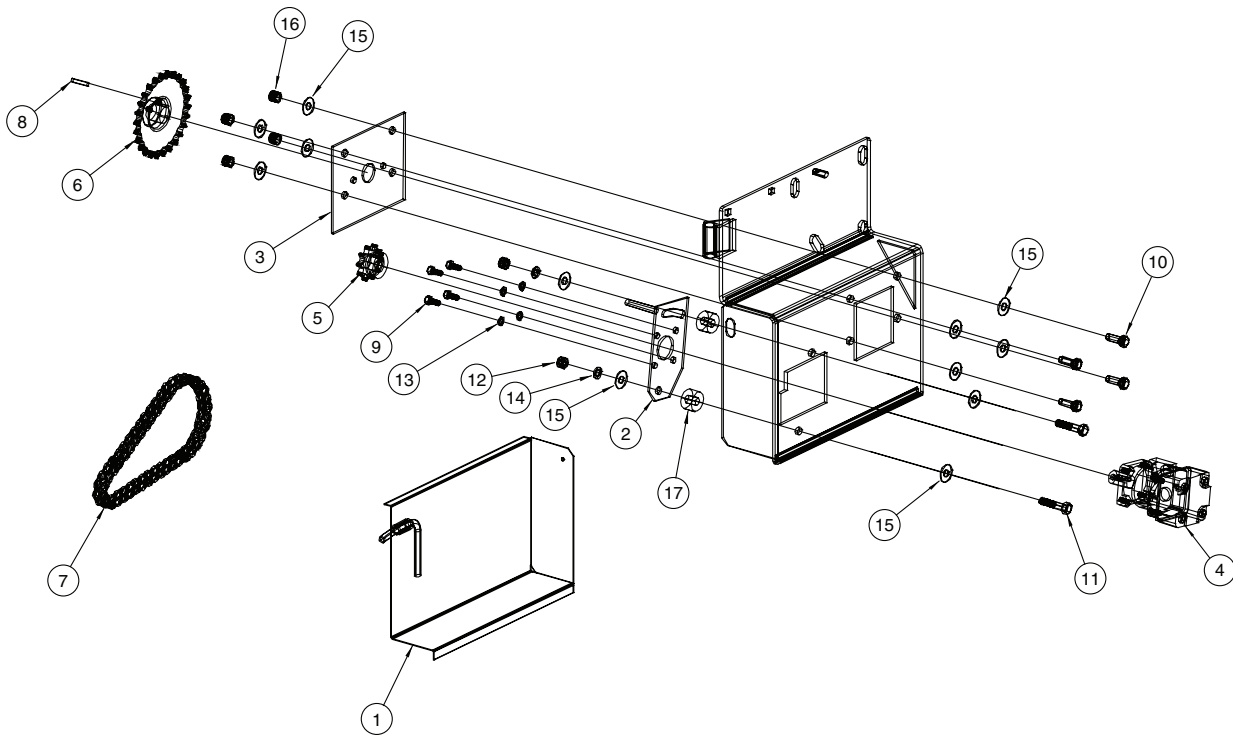

### 00072702 DRIVE KIT, MS996/886, CHAIN

Item	Qty	Part Number	Description
1	1	00021769-A 00021769-B	CHAIN COVER, RH, MS CHAIN COVER, RH, SST
2	1	00022314-A 00022314-B 00022314-C	MOUNTING PLATE WELDMENT, MS MOUNTING PLATE WELDMENT, SST MOUNTING PLATE WELDMENT, AUSST
3	1	00041089-A 00041089-B 00041089-D	ADAPTER PLATE, AUGER, MS ADAPTER PLATE, AUGER, SST ADAPTER PLATE, AUGER, AUSST
4	1	05006549	MOTOR, HYD, WHITE, 10.0 CI, 1" SHAFT See Page 50
5	1	05033010	SPROCKET, 60B10FX1, .25" KEYWAY
6	1	05033014	SPROCKET, 60B26FX1.25, .25" KEYWAY
7	1	05036062	CHAIN ASSY, W/ CONNECTOR LINK
8	1	05050121	KEY, .25 X .25 X 1.5"
9	4	05010642 05016050	BOLT, .375-16 X .875, G8, HHCS, ZINC BOLT, .375-16 X .875, G8, HHCS, SST
10	4	05017108 05017107	BOLT, .5-13 X 1.375, G8, HHCS, ZINC BOLT, .5-13 X 1.375, HHCS, SST
11	2	05010694 05016207	BOLT, .5-13 X 2.5, G8, HHCS, ZINC BOLT, .5-13 X 2.5, G8, HHCS, SST
12	2	05020268 05020848	NUT, .5-13, G8, HEX, ZINC NUT, .5-13, G8, HEX, SST
13	4	05021365 05021392	WASHER, .375, LOCK, ZINC WASHER, .375, LOCK, SST
14	2	05021367 05021396	WASHER, .5, LOCK, ZINC WASHER, .5, LOCK, SST
15	12	05021309 05021391	WASHER, .5, FLAT, ZINC WASHER, .5, FLAT, SST
16	4	05020847 05020908	NUT, .5-13, GC, TOP LOCK, C&W NUT, .5-13, NYLON LOCK, 316 SST
17	2	00054873	SPACER, MOUNTING PLATE, MS, CD, SP SENSOR

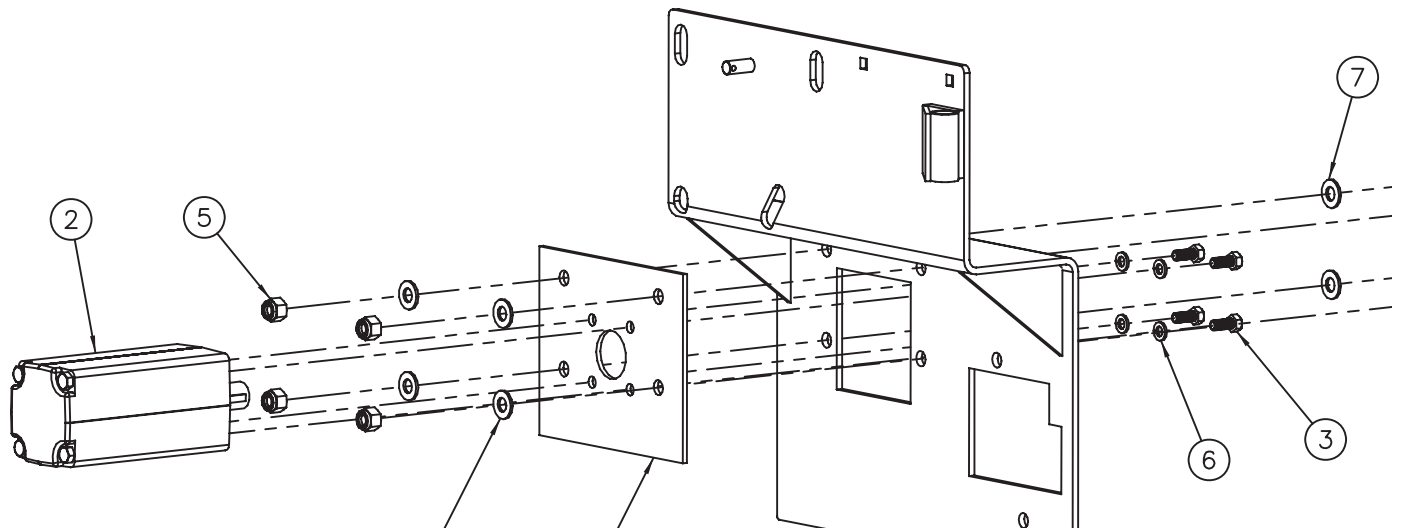

### 00058120 DRIVE KIT, MS996/886, DIRECT

Item	Qty	Part Number	Description
1	1	00041086-A 00041086-B 00041086-D	ADAPTER PLATE, AUGER, MS ADAPTER PLATE, AUGER, SST ADAPTER PLATE, AUGER, AUSST
2	1	05006556	MOTOR, HYD, WHITE, 24 CID, 1" SHAFT See Page 69
3	4	05010642 05016050	BOLT, .375-16 X .875, G8, HHCS, ZINC BOLT, .375-16 X .875, G8, HHCS, SST
4	4	05017108 05017107	BOLT, .5-13 X 1.375, G8, HHCS, ZINC BOLT, .5-13 X 1.375, G8, HHCS, SST
5	4	05020847 05020908	NUT, .5-13, GC, TOP LOCK, C&W NUT, .5-13, NYLON LOCK, 316 SST
6	4	05021365 05021392	WASHER, .375, LOCK, ZINC WASHER, .375, LOCK, SST
7	8	05021367 05021396	WASHER, .5, LOCK, ZINC WASHER, .5, LOCK, SST

## 00068061 DRIVE KIT, MS996/886, DIRECT, WITH SPEED SENSOR

Item	Qty	Part Number	Description
1	1	00041086-A 00041086-B 00041086-D	ADAPTER PLATE, AUGER, MS ADAPTER PLATE, AUGER, SST ADAPTER PLATE, AUGER, AUSST
2	1	05006688	MOTOR, HYD, WHITE, 24 CID, 4-BOLT SENSOR See Page 56
3	4	05010642 05016050	BOLT, .375-16 X .875, G8, HHCS, ZINC BOLT, .375-16 X .875, G8, HHCS, SST
4	4	05017108 05017107	BOLT, .5-13 X 1.375, G8, HHCS, ZINC BOLT, .5-13 X 1.375, G8, HHCS, SST
5	4	05020847 05020908	NUT, .5-13, GC, TOP LOCK, C&W NUT, .5-13, G8, NYLON LOCK, 316, SST
6	4	05021365 05021392	WASHER, .375, LOCK, ZINC WASHER, .375, LOCK, SST
7	8	05021309 05021391	WASHER, .5, FLAT, ZINC WASHER, .5, FLAT, SST

HARDWARE FOR ATTACHING ADAPTER PLATE (00041086-A/B/D)

- 4-BOLT (05017108/05017107)
- 4-NUT (05020847/05020908)
- 4-WASHER (05021309/05021391)

HARDWARE FOR ATTACHING MOTOR (05006688)

- 4-BOLT (05010642/05016050)
- 4-WASHER (05021365/05021392)

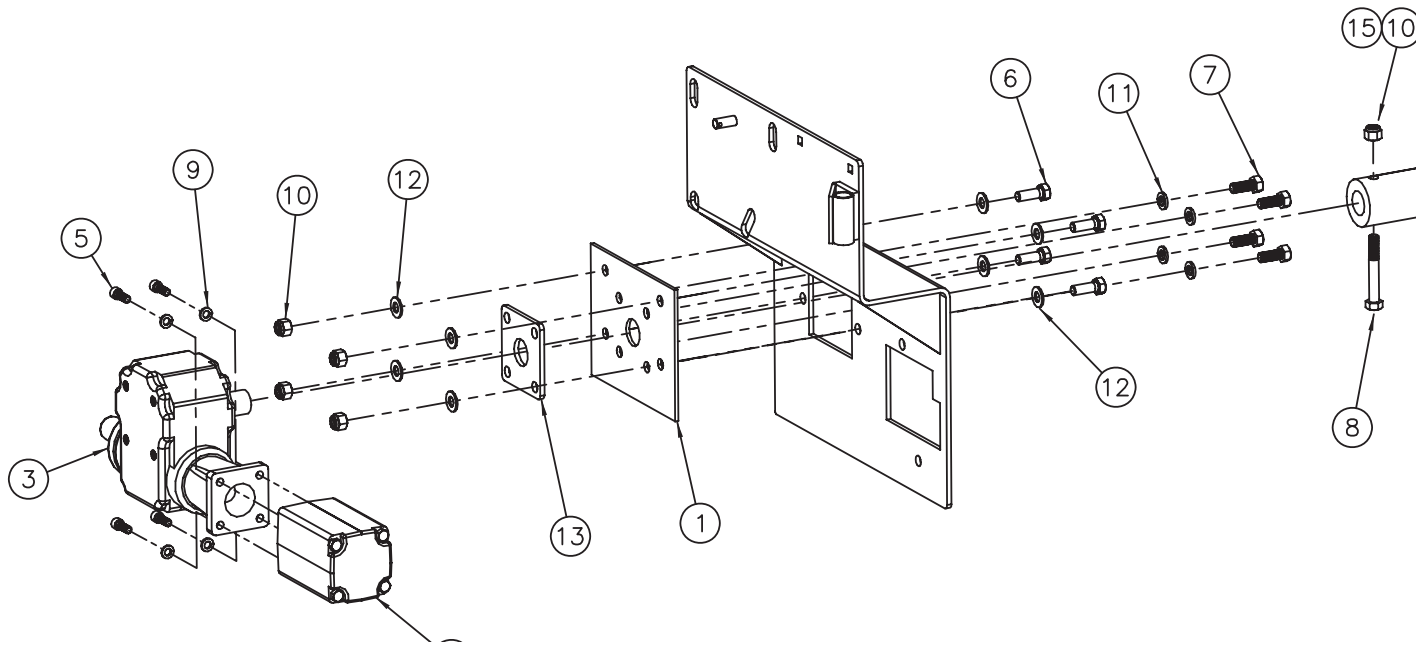

### 00058122 DRIVE KIT, MS966/886, GEARBOX

Item	Qty	Part Number	Description
1	1	00041083-A 00041083-B 00041083-D	ADAPTER PLATE, AUGER, MS ADAPTER PLATE, AUGER, 304 SST ADAPTER PLATE, AUGER, AUSST
2	1	05006550	MOTOR, HYD, WHITE, 6.3CID, 1" SHAFT See Page 71
3	1	05007338	GEAR BOX, 5:1, 1.25 SHAFT, 6 LONG, See Page 75
4	1	05051325	BUSHING, UHMW, 2.468" OD X 1.28
5	4	05017051	BOLT, .375-16 X 1, SHCS, ZINC
6	4	05017108 05017107	BOLT, .5-13 X 1.375, HHCS, ZINC BOLT, .5-13 X 1.375, HHCS, SST
7	4	05010690 05016045	BOLT, .5-13 X 1.250, HHCS, ZINC BOLT, .5-13 X 1.250, HHCS, SST
8	1	05010699	BOLT, .5-13 X 3.5, G8, HHCS, ZINC
9	4	05021365	WASHER, .375 LOCK ZINC
10	5 4	05020847 05020908	NUT, .5-13, GC, TOP LOCK, C&W NUT, .5-13 NYLON LOCK, 316 SST
11	4	05021367 05021396	WASHER, .5, LOCK, ZINC WASHER, .5, LOCK, SST
12	8	05021309 05021391	WASHER, .5, FLAT, ZINC WASHER, .5, FLAT, SST
13	1	00093860	SPACER PLATE, GEARBOX, MS886/966, UHMW
15	1	05020847	NUT, .5-13, TOP LOCK, C&W



## 00072701 DRIVE KIT, MS966/886, GEARBOX, WITH SPEED SENSOR

Item	Qty	Part Number	Description
1	1	00041083-A 00041083-B 00041083-D	ADAPTER PLATE, AUGER, MS ADAPTER PLATE, AUGER, 304 SST ADAPTER PLATE, AUGER, AUSST
2	1	05006687	MOTOR, HYD, WHITE, 6.3CID, 1" SHAFT
3	1	05007338	GEAR BOX, 5:1, 1.25 SHAFT, 6 LONG, 4-B See Page 48
4	1	05051325	BUSHING, UHMW, 2.468" OD X 1.28 See Page 75
5	4	05017059	BOLT, .375-16 X 1, SHCS, ZINC
6	4	05017108 05017107	BOLT, .5-13 X 1.375, HHCS, ZINC BOLT, .5-13 X 1.375, HHCS, SST
7	4	05010690 05016045	BOLT, .5-13 X 1.250, HHCS, ZINC BOLT, .5-13 X 1.250, HHCS, SST
8	1	05010699	BOLT, .5-13 X 3.5, G8, HHCS, ZINC
9	4	05021365	WASHER, .375, LOCK, ZINC
10	5 4	05020847 05020908	NUT, .5-13, GC, TOP LOCK, C&W NUT, .5-13, NYLON LOCK, 316 SST
11	4	05021367 05021396	WASHER, .5, LOCK, ZINC WASHER, .5, LOCK, SST
12	8	05021309 05021391	WASHER, .5, FLAT, ZINC WASHER, .5, FLAT, SST
13	1	00093860	SPACER PLATE, GEARBOX, UHMW
15	1	05020848	NUT, .5-13, HEX, SST <b>(USED ON SST)</b>

HARDWARE FOR ATTACHING ADAPTER PLATE (00041083-A/B/D)

- 4-BOLT (05017108/05017107)
- 4-NUT (05020847/05020908)
- 4-WASHER (05021309/05021391)

HARDWARE FOR ATTACHING GEARBOX (05007338)

- 4-BOLT (05010690/05016045)
- 4-WASHER (05021367/05021396)

HARDWARE FOR ATTACHING MOTOR (05006687)

- 4-BOLT (05017059)
- 4- WASHER (05021365)

HARDWARE FOR ATTACHING AUGER FOR GEAR BOX DRIVE

- 1-BUSHING (05051325)
- 1-BOLT (05010699)
- 1-NUT (05020847)

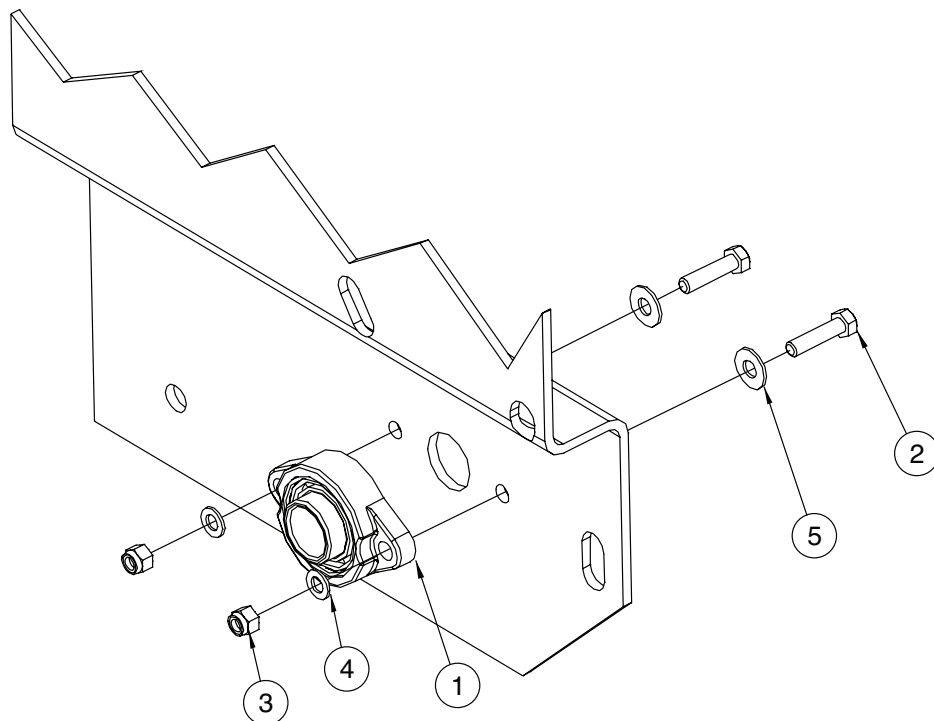

**00021724-A BEARING KIT, 1.25, 2-BOLT, MS**  
**00021724-B BEARING KIT, 1.25, 2-BOLT, SST**

Item	Qty	Part Number	Description
1	1	05030024	BEARING, S1037.20, 1.250", 2-BOLT
2	2	05010645 05016162	BOLT, .375-16 X 1.250, G8, HHCS, ZINC BOLT, .375-16 X 1.250, HHCS, SST
3	2	05020898 05020891	NUT, .375-16, GC TOP LOCK, C&W NUT, .375-16, NYLON LOCK, 316 SST
4	2	05021013 05021390	WASHER, .375, FLAT, MIL-CARB, SAE WASHER, .375, FLAT, SAE, SST
5	2	05021307 05021418	WASHER, .375, FLAT, ZINC WASHER, .375, FLAT, SS

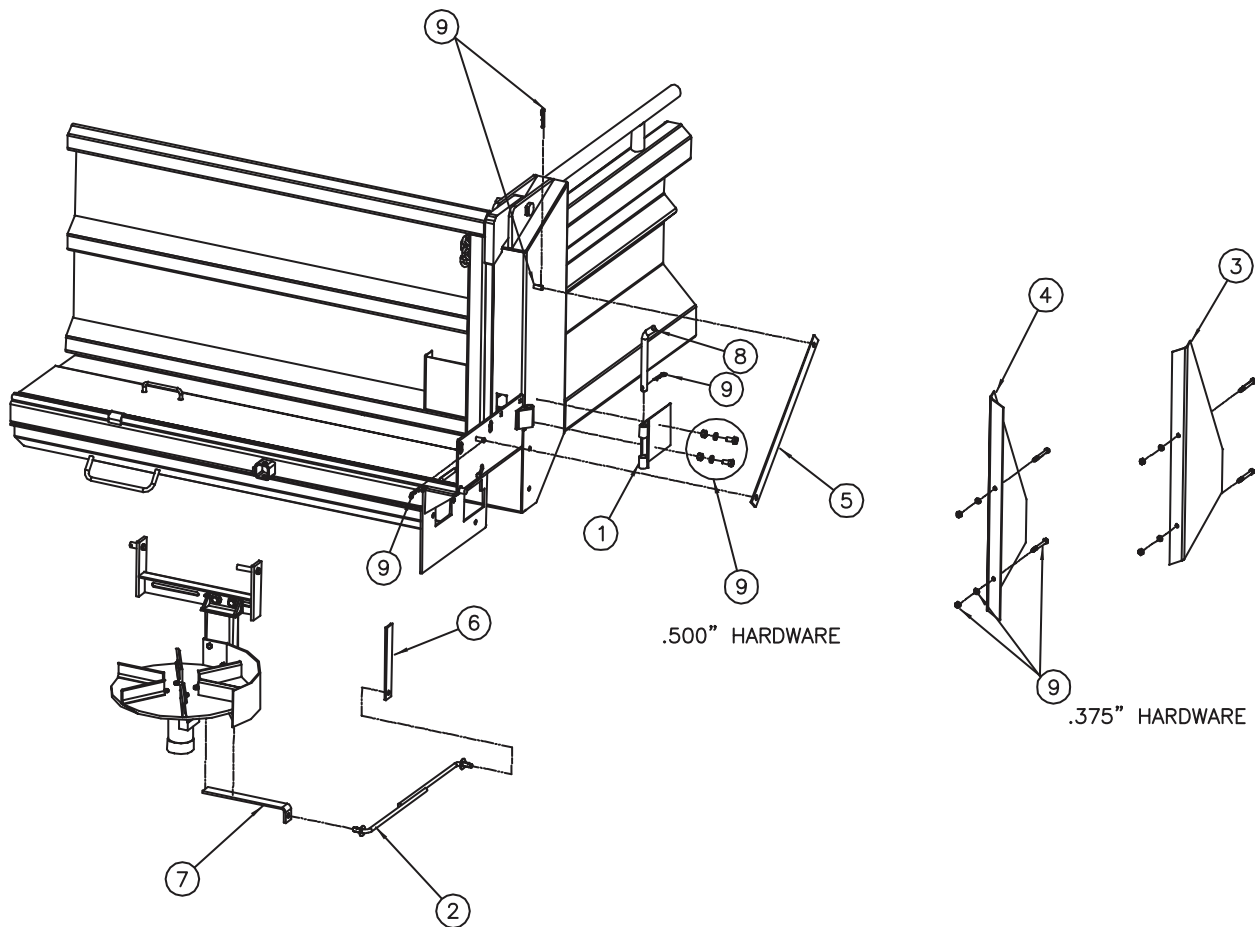

### 00054882 MOUNTING KIT, UT

Item	Qty	Part Number	Description
1	2	00097668-A 00097668-B	BRACKET WELDMENT, BODY, QD, MS BRACKET WELDMENT, BODY, QD, SST
2	4	00041156-A 00041156-B	STABILIZER ROD WELDMENT, MS STABILIZER ROD WELDMENT, SST
3	1	00021207-A 00021207-B	SHIELD, TAILGATE, RH, MS SHIELD, TAILGATE, RH, SST
4	1	00021208-A 00021208-B	SHIELD, TAILGATE, LH, MS SHIELD, TAILGATE, LH, SST
5	2	00041118-A 00041118-B	HANGER, SUPPORT, MS HANGER, SUPPORT, SST
6	2	00041121-A 00041121-B	STABILIZER, SPINNER, MS STABILIZER, SPINNER, SST
7	2	00041124-A 00041124-B	BRACKET, STABILIZER, MS BRACKET, STABILIZER, SST
8	2	00041074-A 00041074-B	PIN, QUICK DETACH, MS PIN, QUICK DETACH, SST
9	1	05016907-A 05016907-B	BOLT KIT, MOUNTING, MS BOLT KIT, MOUNTING, SST

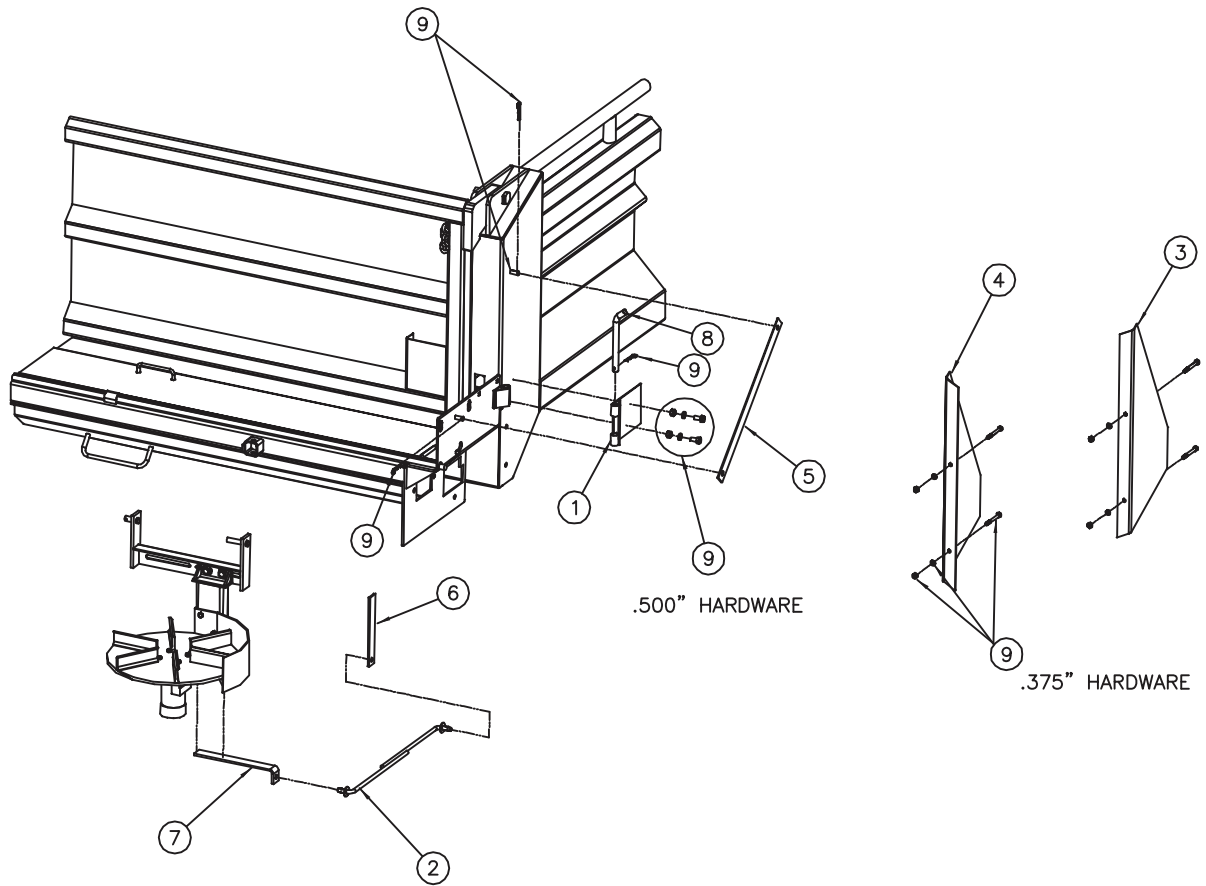

<b>00097670-A MOUNTING KIT, UT, MS</b> <b>00097670-B MOUNTING KIT, UT, SST</b>			
Item	Qty	Part Number	Description
1	2	00097668-A 00097668-B	BRACKET WLDMT, QUICK DETACH, MS BRACKET WLDMT, QUICK DETACH, SST
2	2	00041156-A 00041156-B	STABILIZER ROD WLDMT, MS STABILIZER ROD WLDMT, SST
3	1	00021207-A 00021207-B	SHIELD, TAILGATE, RH, MS SHIELD, TAILGATE, RH, SST
4	1	00021208-A 00021208-B	SHIELD, TAILGATE, LH, MS SHIELD, TAILGATE, LH, SST
5	2	00041118-A 00041118-B	HANGER, SUPPORT, MS HANGER, SUPPORT, SST
6	1	00041121-A 00041121-B	STABILIZER, SPINNER, MS STABILIZER, SPINNER, SST
7	1	00041124-A 00041124-B	BRACKET, STABILIZER, MS BRACKET, STABILIZER, SST
8	2	00041074-A 00041074-B	PIN, QUICK DETACH, HRR PIN, QUICK DETACH, SSR
9	1	05016907-A 05016907-B	BOLT KIT MOUNTING, MS BOLT KIT MOUNTING, SST

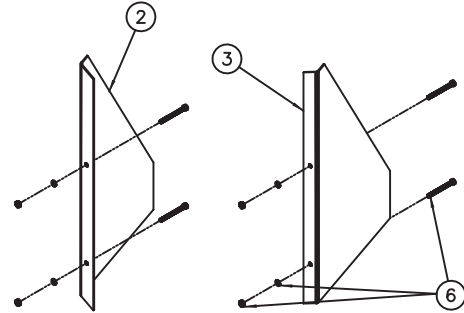
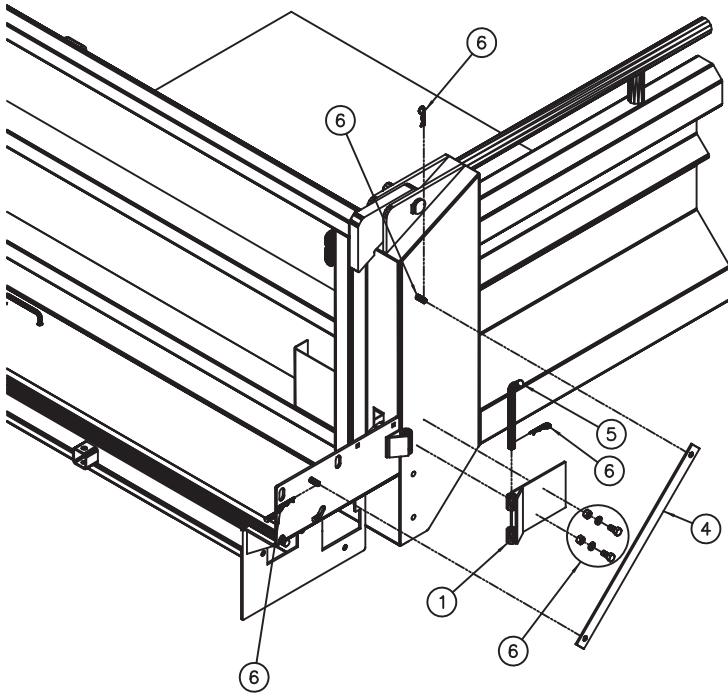

**00092648-A MOUNTING KIT, UT, SELF LEVELING, MS**  
**00092648-B MOUNTING KIT, UT, SELF LEVELING, SST**

Item	Qty	Part Number	Description
1	2	00097668-A 00097668-B	BRACKET WELDMENT, QUICK DETACH, MS BRACKET WELDMENT, QUICK DETACH, SST
2	1	00021207-A 00021207-B	SHIELD, TAILGATE, RH, MS SHIELD, TAILGATE, RH, SST
3	1	00021208-A 00021208-B	SHIELD, TAILGATE, LH, MS SHIELD, TAILGATE, LH, SST
4	2	00041118-A 00041118-B	HANGER, SUPPORT, MS HANGER, SUPPORT, SST
5	2	00041074-A 00041074-B	PIN, QUICK DETACH, HRR PIN, QUICK DETACH, SSR
6	1	05016907-A 05016907-B	BOLT KIT, MOUNTING, MS BOLT KIT, MOUNTING, SST

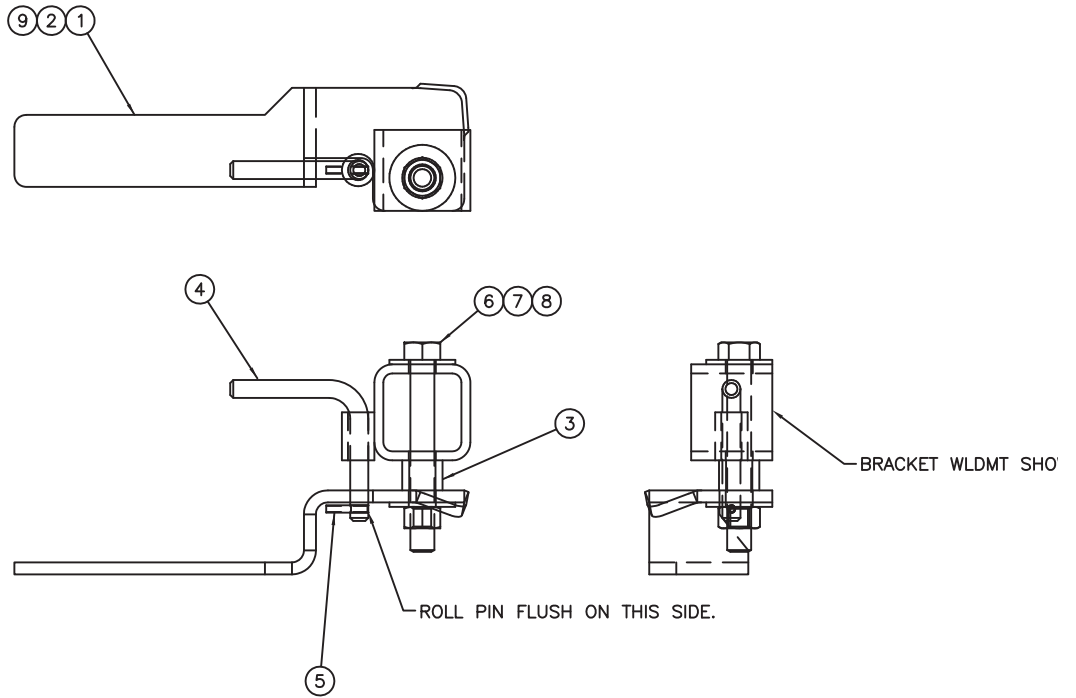

**00097647-A LATCH KIT, UT, Z-HANDLE, MS**  
**00097647-B LATCH KIT, UT, Z-HANDLE, SST**

Item	Qty	Part Number	Description
1	1	00097645-A 00097645-B	HANDLE, LATCH, TROUGH BOTTOM, RH, MS HANDLE, LATCH, TROUGH BOTTOM, RH, SST
2	1	00097646-A 00097646-B	HANDLE, LATCH, TROUGH BOTTOM, LH, MS HANDLE, LATCH, TROUGH BOTTOM, LH, SST
3	2	00097675-A 00097675-B	PIPE, .5 SCHED 80 X .625, MS PIPE, .5 SCHED 80 X .625, SST
4	2	00098579	PIN, .375 DIA X3.375 OAL, 2.672 GL
5	2	05022072	PIN, .156 X .875, ROLL, ZINC
6	2	05010701	BOLT, .5-13 X 4, G8, HHCS, ZINC
7	2	05020847	NUT, .5-13, GC, TOP LOCK, C&W
8	4	05021309	WASHER, .5, FLAT, ZINC

**00041644-A/B ANTI-FLOW PLATE WELDMENT**

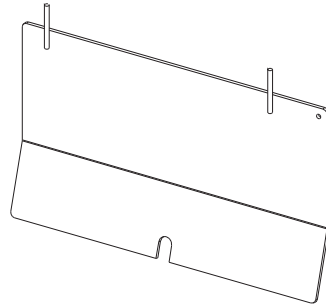

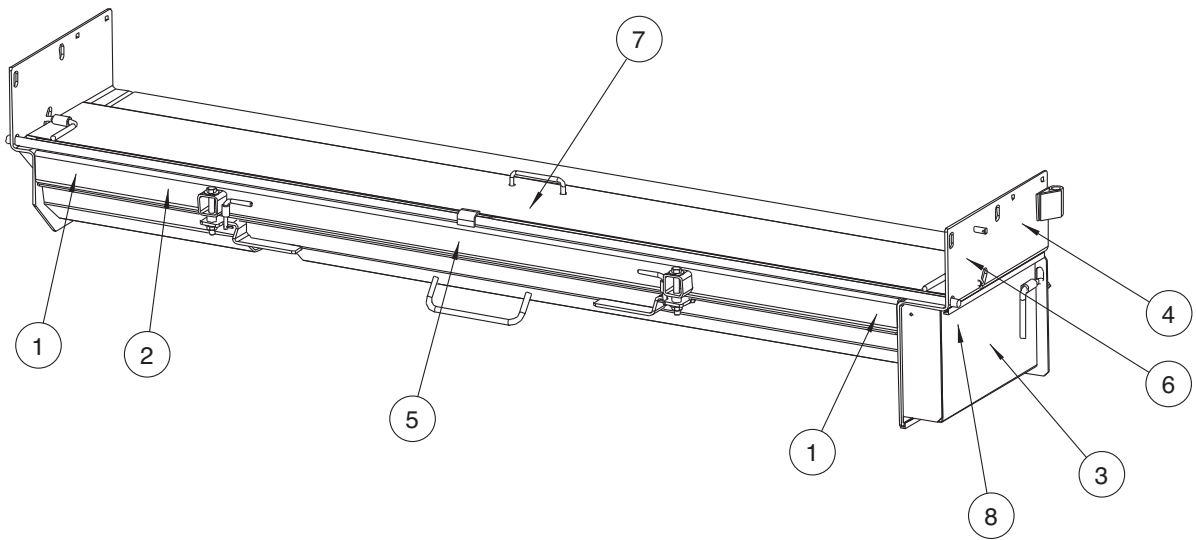

00058135 DECAL KIT,TGT SPREADER,CHAIN DR			
Item	Qty.	Part Number	Description
1	2	05051401	DECAL,DANGER:TURNING AUGERS...
2	1	05051402	DECAL,DANGER:TURNING SPINNERS.
3	1	05051403	DECAL,SAFETY CHAIN COVER
4	1	05051404	DECAL,CAUTION #1-#6
5	1	05051405	DECAL,MONROE SPREADER
6	1	05052311	DECAL,QUALITY CHECK
7	1	05051625	DECAL,MONROE SNOW & ICE CONTROL
8	1	05052310	DECAL,DANGER:KEEP GUARDS IN PLACE

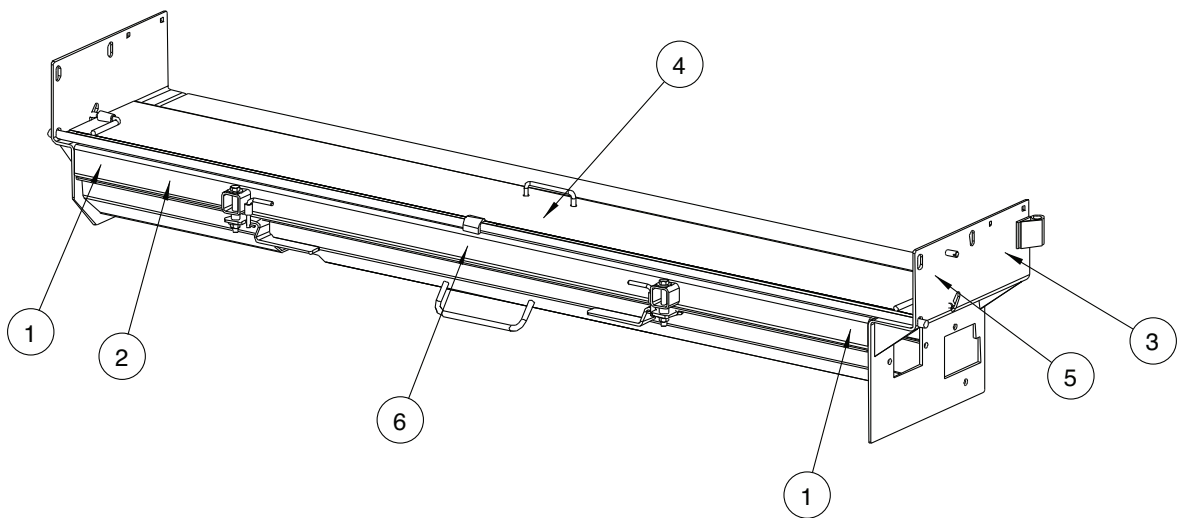

00058134 DECAL KIT,TGT SPREADER,GB/DD			
Item	Qty.	Part Number	Description
1	2	05051401	DECAL,DANGER:TURNING AUGERS...
2	1	05051402	DECAL,DANGER:TURNING SPINNERS.
3	1	05051404	DECAL,CAUTION #1-#6
4	1	05051625	DECAL,MONROE SNOW & ICE CONTROL
5	1	05052311	DECAL,QUALITY CHECK
6	1	05051405	DECAL,21.0x2.5,MONROE SPREADER



# 00026544 SPINNER ASSEMBLY, LH

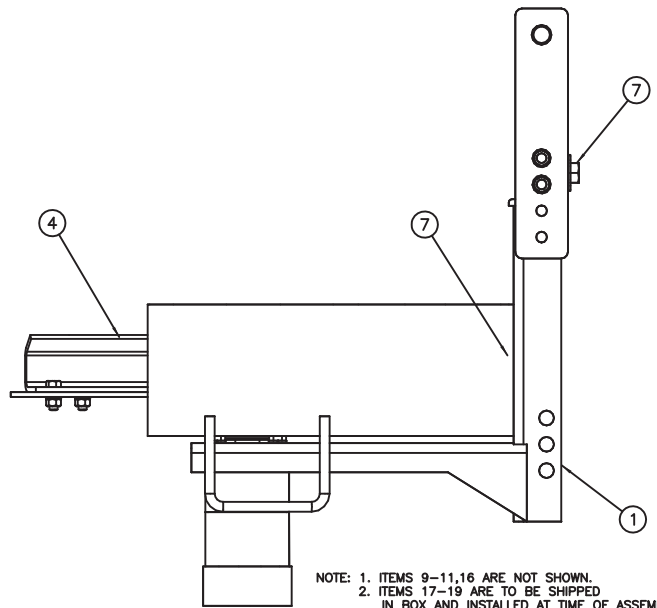
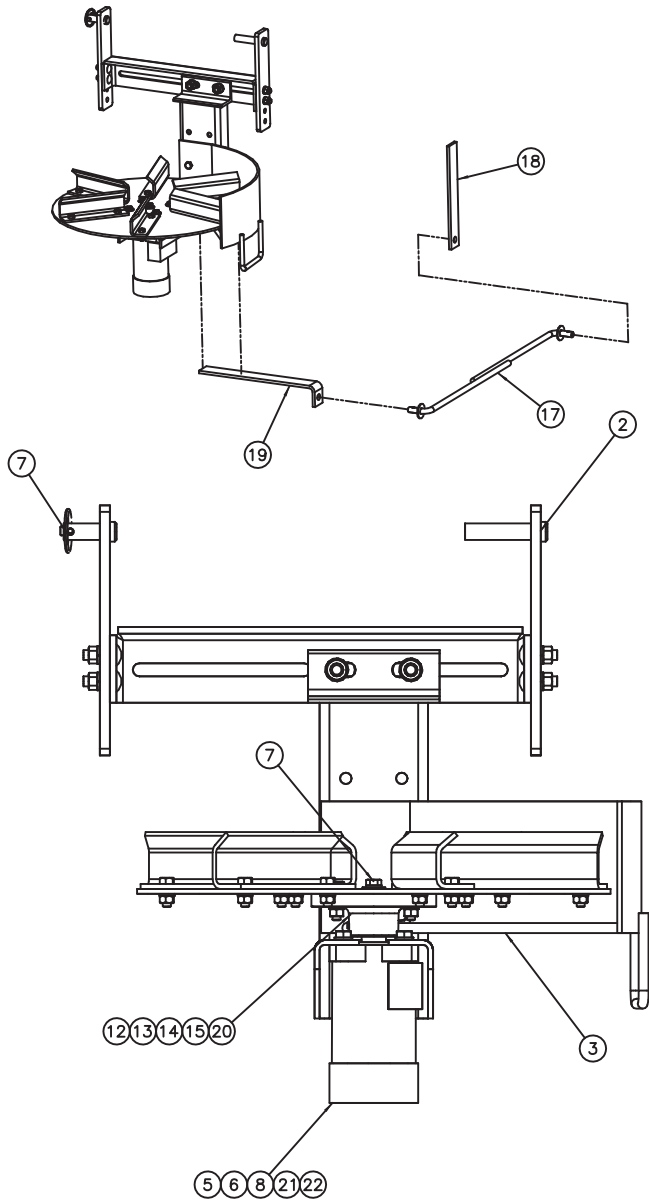

NOTE: 1. ITEMS 9-11,16 ARE NOT SHOWN.  
 2. ITEMS 17-19 ARE TO BE SHIPPED  
 IN BOX AND INSTALLED AT TIME OF ASSEMBLY.

**00026544 SPINNER ASSEMBLY, TGT, LH SEAL SAVER**

<b>Item</b>	<b>Qty.</b>	<b>Part Number</b>	<b>Description</b>
1	1	00026543-A	FRAME WLDMT,SPINNER,TGT,MS
1	1	00026543-B	FRAME WLDMT,SPINNER,TGT,304SS
1	1	00026543-C	FRAME WLDMT,SPINNER,TGT,AUSST
2	1	00103663-A	HANGER ASSEMBLY,SPINNER,TGT,MS
2	1	00103663-B	HANGER ASSEMBLY,SPINNER,TGT,AUSST
3	1	00105117-A	SHIELD WLDMT,LH,SPINNER,TGT,MS
3	1	00105117-B	SHIELD WLDMT,LH,SPINNER,TGT,304SS
4	1	00099401-A	SPINNER DISC ASSY,18,CCW,MS <i>See Page 46</i>
4	1	00099401-B	SPINNER DISC ASSY,18,CCW,304
4	1	00099401-D	SPINNER DISC ASSY,18,CCW,AUSST
4	1	05050071-B	DISC,SPINNER,18"CCW,POLY
5	1	05006673	MOTOR,HYD,WHITE,3.2CI,4B,1"EXT <i>See Page 73</i>
6	4	05010645	BOLT .375-16 x 1.50 G8 HHCS ZC
6	4	05016162	BOLT .375-16 x 1.50 HHCS SS
7	1	05016906-A	BOLT KIT,SPINNER,MS,MT UNDER
7	1	05016906-B	BOLT KIT,SPINNER,MS,MT UNDER
8	4	05021365	WASHER .375 LOCK ZC
8	4	05021392	WASHER .375 LOCK SS
12	1	05051380	HUB,SPINNER ASSY,STD,SHORT,W/SET SCREW
13	4	05010619	BOLT .313-18 x 1.25 G8 HHCS ZC
13	4	05016139	BOLT .313-18 x 1.25 HHCS SS
13	4	05016140	BOLT .313-18 x 1.50 HHCS SS
14	4	05020265	NUT .313-18 G8 HEX ZC
14	4	05020855	NUT .313-18 HEX SS
15	4	05021364	WASHER .313 LOCK ZC
15	4	05021407	WASHER .313 LOCK SS
16	1	05052485	TRASH LINER,CLEAR 40 x 46
17	2	00041156-A	STABILIZER ROD WLDMT,MS-UT,MS
17	2	00041156-B	STABILIZER ROD WLDMT,MS-UT,304
18	1	00041121-A	STABILIZER,SPINNER,MS-UT,MS
18	1	00041121-B	STABILIZER,SPINNER,MS-UT,304
19	1	00041124-A	BRACKET,STABILIZER,MS-UT,MS
19	1	00041124-B	BRACKET,STABILIZER,MS-UT,304
20	4	05021306	WASHER .313 FLAT ZC
20	4	05021404	WASHER .313 FLAT SS
21	1	00122073	SEAL SAVER,MOTOR,SPINNER
22	1	05050288	GREASE ZERK,.250-28 STRAIGHT

00026548 SPINNER ASSEMBLY, CENTER

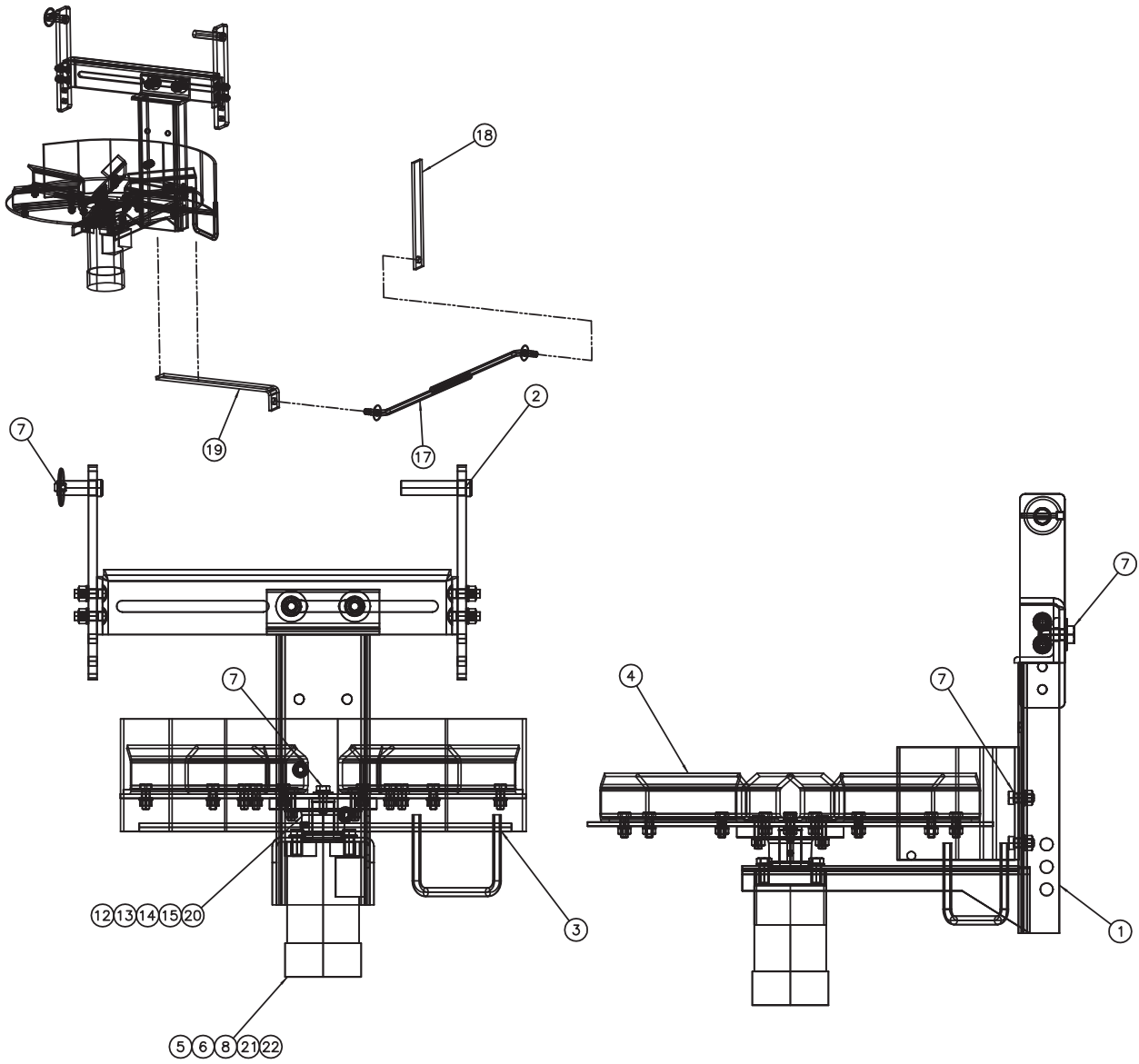

**00026548 SPINNER ASSEMBLY, TGT, CENTER**

<b>Item</b>	<b>Qty.</b>	<b>Part Number</b>	<b>Description</b>
1	1	00026543-A	FRAME WLDMT, SPINNER, TGT, MS
1	1	00026543-B	FRAME WLDMT, SPINNER, TGT, 304SS
1	1	00026543-C	FRAME WLDMT, SPINNER, TGT, AUSST
2	1	00103663-A	HANGER ASSEMBLY, SPINNER, TGT, MS
2	1	00103663-B	HANGER ASSEMBLY, SPINNER, TGT, AUSST
3	1	00105119-A	SHIELD WLDMT, CD, SPINNER, TGT, MS
3	1	00105119-B	SHIELD WLDMT, CD, SPINNER, TGT, 304SS
4	1	00099401-A	SPINNER DISC ASSY, 18, CCW, MS <i>See Page 46</i>
4	1	00099401-B	SPINNER DISC ASSY, 18, CCW, 304SS
4	1	00099401-D	SPINNER DISC ASSY, 18, CCW, AUSST
4	1	05050071-B	DISC, SPINNER, 18"CCW, POLY,
5	1	05006673	MOTOR, HYD, WHITE, 3.2CI, 4B, 1"EXT <i>See Page 73</i>
6	4	05010645	BOLT .375-16 x 1.50 HHCS ZC
6	4	05016162	BOLT .375-16 x 1.50 HHCS SS
7	1	05016906-A	BOLT KIT, SPINNER, MS, MT UNDER
7	1	05016906-B	BOLT KIT, SPINNER, MS, MT UNDER
8	4	05021365	WASHER .375 LOCK ZC
8	4	05021392	WASHER .375 LOCK SS
12	1	05051380	HUB, SPINNER ASSY, STD, SHORT, W/SET SCREW
13	4	05010619	BOLT .313-18 x 1.25 G8 HHCS ZC
13	4	05016139	BOLT .313-18 x 1.25 HHCS SS
14	4	05020265	NUT .313-18 G8 HEX ZC
14	4	05020855	NUT .313-18 HEX SS
15	4	05021364	WASHER .313 LOCK ZC
15	4	05021407	WASHER .313 LOCK SS
16	1	05052485	TRASH LINER, CLEAR 40 x 46
17	2	00041156-A	STABILIZER ROD WLDMT, MS-UT, MS
17	2	00041156-B	STABILIZER ROD WLDMT, MS-UT, 304
18	1	00041121-A	STABILIZER, SPINNER, MS-UT, MS
18	1	00041121-B	STABILIZER, SPINNER, MS-UT, 304
19	1	00041124-A	BRACKET, STABILIZER, MS-UT, MS
19	1	00041124-B	BRACKET, STABILIZER, MS-UT, 304
20	4	05021306	WASHER .313 FLAT ZC
20	4	05021404	WASHER .313 FLAT SS
21	1	00122073	SEAL SAVER, MOTOR, SPINNER
22	1	05050288	GREASE FITTING, .250-28 UNF ST

# 00026549 SPINNER ASSEMBLY, RH

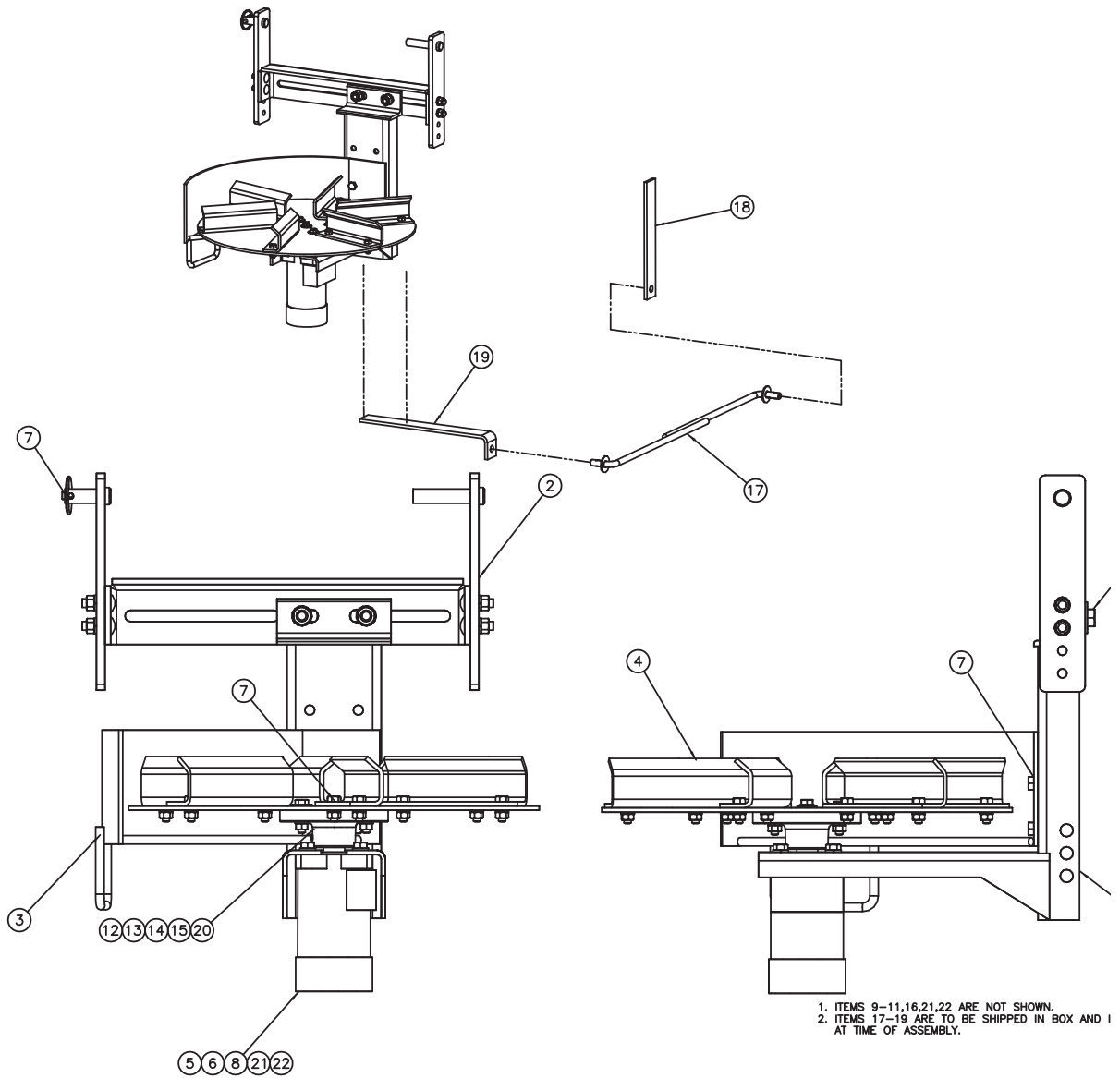

**00026549 SPINNER ASSEMBLY, TGT, RH**

<b>Item</b>	<b>Qty.</b>	<b>Part Number</b>	<b>Description</b>
1	1	00026543-A	FRAME WLDMT,SPINNER,TGT,MS
1	1	00026543-B	FRAME WLDMT,SPINNER,TGT,304SS
2	1	00103663-A	HANGER ASSEMBLY,SPINNER,TGT,MS
2	1	00103663-B	HANGER ASSEMBLY,SPINNER,TGT,304SS
3	1	00105118-A	SHIELD WLDMT,RH,SPINNER,TGT,MS
3	1	00105118-B	SHIELD WLDMT,RH,SPINNER,TGT,304SS
4	1	00099400-A	SPINNER DISC ASSY,18,CW,MS <i>See Page 47</i>
4	1	00099400-B	SPINNER DISC ASSY,18,CW,304SS
4	1	05051054	DISC,SPINNER,18"CW,POLY,RED
5	1	05006673	MOTOR,HYD,WHITE,3.2CI,4B,1"EXT <i>See Page 73</i>
6	4	05010645	BOLT .375-16 x 1.50 G8 HHCS ZC
7	1	05016906-A	BOLT KIT,SPINNER,MS,MT UNDER
7	1	05016906-B	BOLT KIT,SPINNER,MS,MT UNDER
8	4	05021365	WASHER .375 LOCK ZC
8	4	05021392	WASHER .375 LOCK SS
12	1	05051380	HUB,SPINNER ASSY,STD,SHORT,W/SET SCREW
13	4	05010619	BOLT .313-18 x 1.25 G8 HHCS ZC
13	4	05010620	BOLT .313-18 x 1.50 G8 HHCS ZC
13	4	05016139	BOLT .313-18 x 1.25 HHCS SS
13	4	05016140	BOLT .313-18 x 1.50 HHCS SS
14	4	05020265	NUT .313-18 G8 HEX ZC
14	4	05020855	NUT .313-18 HEX SS
15	4	05021364	WASHER .313 LOCK ZC
15	4	05021407	WASHER .313 LOCK SS
16	1	05052485	TRASH LINER,CLEAR 40 x 46
17	2	00041156-A	STABILIZER ROD WLDMT,MS-UT,MS
17	2	00041156-B	STABILIZER ROD WLDMT,MS-UT,304
18	1	00041121-A	STABILIZER,SPINNER,MS-UT,MS
18	1	00041121-B	STABILIZER,SPINNER,MS-UT,304
19	1	00041124-A	BRACKET,STABILIZER,MS-UT,MS
19	1	00041124-B	BRACKET,STABILIZER,MS-UT,304
20	4	05021306	WASHER .313 FLAT ZC
20	4	05021404	WASHER .313 FLAT SS
21	1	00122073	SEAL SAVER,MOTOR,SPINNER
22	1	05050288	GREASE FITTING, .250-28 UNF ST

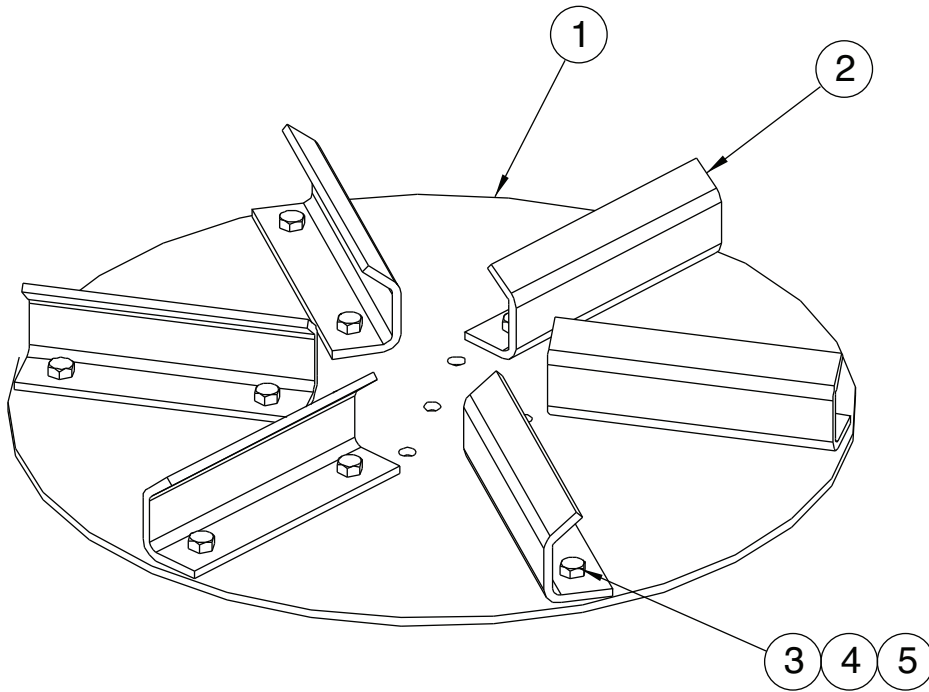

**00099401-A DISC ASSEMBLY, SPINNER, 18" CCW, MS**  
**00099401-B DISC ASSEMBLY, SPINNER, 18" CCW, 304 SST**  
**00099401-C DISC ASSEMBLY, SPIPNNER, 18" CCW, AR**

Item	Qty	Part Number	Description
1	1	00080420-A 00080420-B 00080420-D	DISC, SPINNER, 18" MS DISC, SPINNER, 18", 304 DISC SPINNER, 18", AR
2	6	00080425-A 00080425-B	FLITE SPINNER, MS FLITE SPINNER, SST
3	12	05010617 05016137	BOLT, .312-18 X .875, G8, HHCS, ZINC BOLT, .312-18 X .875, HHCS, SST
4	12	05020265 05020855	NUT, .312-18, G8, HEX, ZINC NUT, .312-18, G8, HEX, SST
5	12	05021364 05021407	WASHER, .312, LOCK, ZINC WASHER, .312, LOCK, SST

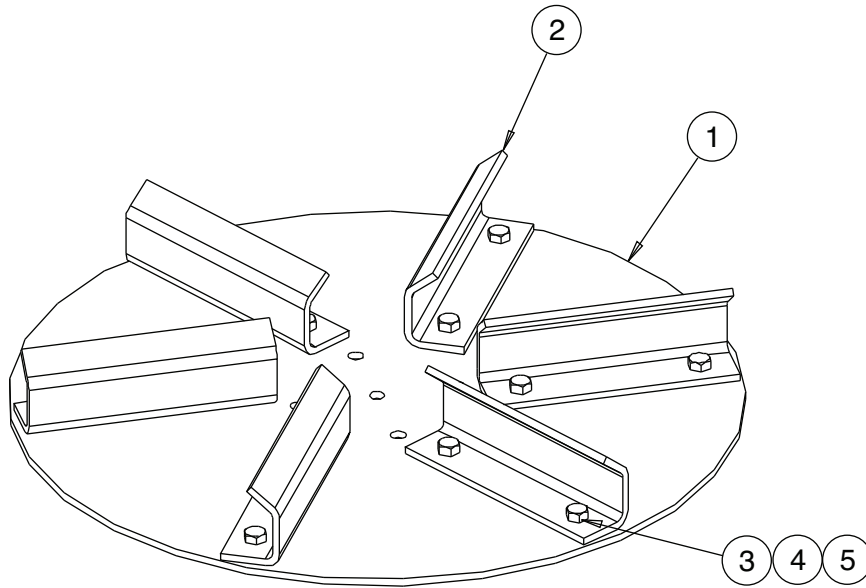

**00099400-A DISC ASSEMBLY, SPINNER, 18" CW, MS**  
**00099400-B DISC ASSEMBLY, SPINNER, 18" CW, 304 SST**  
**00099400-C DISC ASSEMBLY, SPIPNNER, 18" CW, AR**

Item	Qty	Part Number	Description
1	1	00080420-A 00080420-B 00080420-D	DISC, SPINNER, 18" MS DISC, SPINNER, 18", 304 DISC SPINNER, 18", AR
2	6	00080425-A 00080425-B	FLITE SPINNER, MS FLITE SPINNER, SST
3	12	05010617 05016137	BOLT, .312-18 X .875, G8, HHCS, ZINC BOLT, .312-18 X .875, HHCS, SST
4	12	05020265 05020855	NUT, .312-18, G8, HEX, ZINC NUT, .312-18, G8, HEX, SST
5	12	05021364 05021407	WASHER, .312, LOCK, ZINC WASHER, .312, LOCK, SST



05006687 MOTOR, HYD, WHITE, 6.3CI, 4B,  
100PS SENSOR, BH, LOW VOLTAGE, .875 ORB

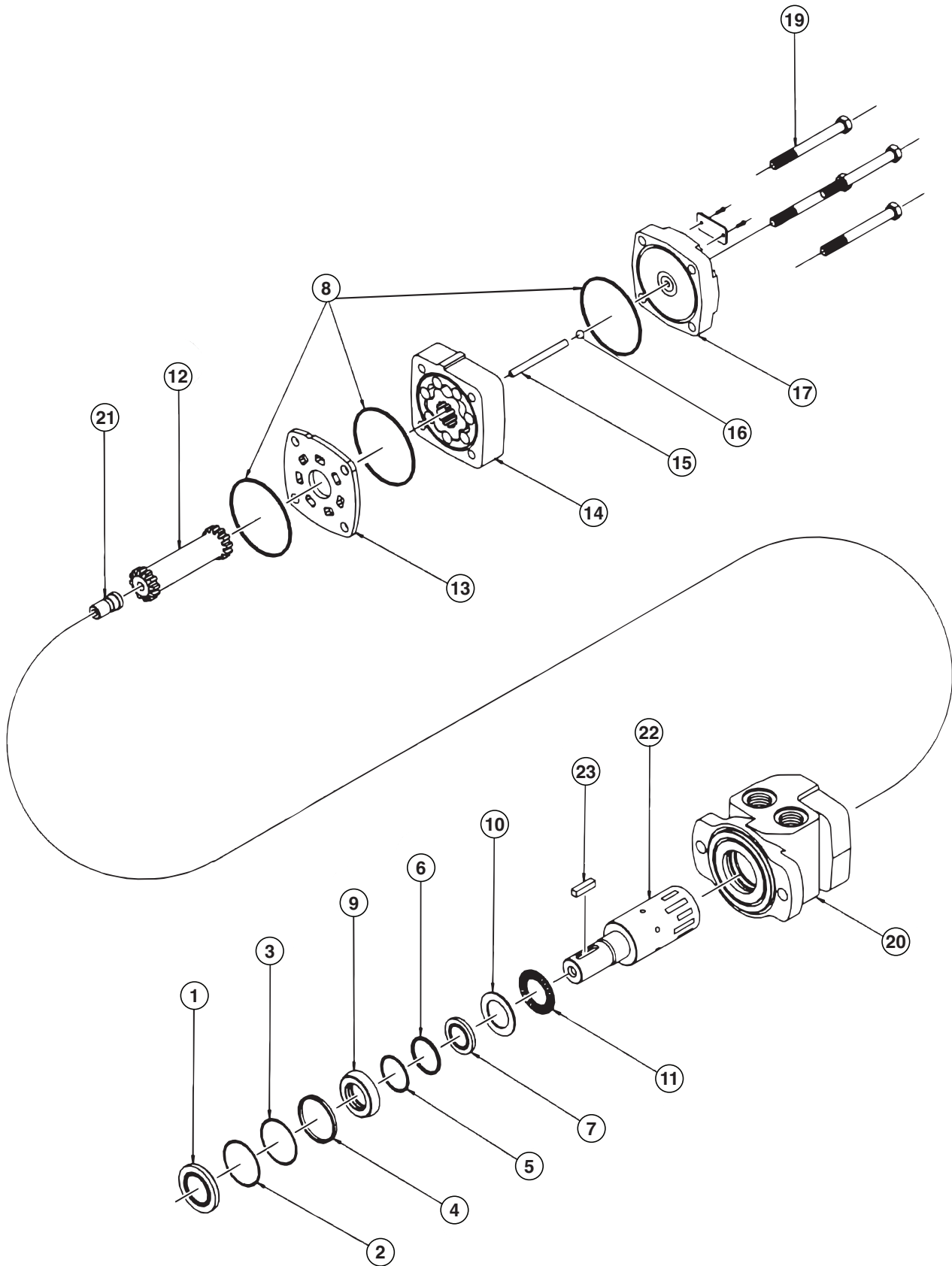

## MOTOR ASSEMBLY PARTS LIST

Item	Part Number	Description
1	Seal Kit 05006679	Dust Seal
2		Split Wire Ring
3		Metal Backup Shim
4		High Pressure Seal
5		Metal Backup Shim
6		Teflon Backup Shim
7		Shaft Seal
8		Body Seals (3)
9		Seal Carrier
10		Thrust Washer
11	05006357	Thrust Bearing
12	05006574	Drive Link Kit
13	05006359	Wear Plate
14	05006573	Rotor Kit
15	05006575	Drive Link Pin Kit
16	---	Included in item #15 Drive Link Pin Kit
17	05006360	End Cover
18	---	Serial Number Plate
19	05006576	Bolt Set Kit
20	05006564	Housing Kit, 4-Hole, w/ 7/8" O-Ring
21	05006358	Cooling Plug
22	05006410	Shaft Kit 1" Straight Speed Sensor
23	---	Key Kit, 1" Straight

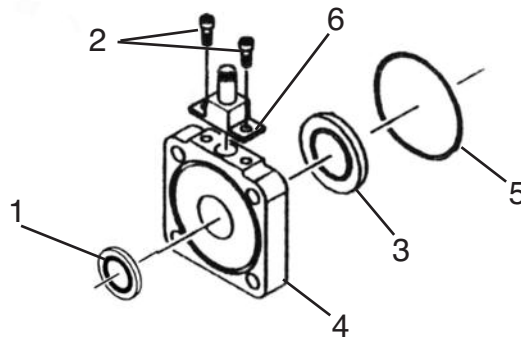

## SPEED SENSOR KIT

Item	Qty	Part Number	Description
1	1	05006560	Dust Seal
2	2	05006561	Sensor Attachment Screw
3	1	05006600	Sensor Magnet
4	1	05006418	4-Hole Sensor Flange
5	1	05006601	4-Hole Sensor Flange Seal
6	1	05006629	Speed Sensor ONLY - 100 Pulse

05006549 MOTOR, HYDRAULIC, WHITE, 10 CI, 4 BOLT

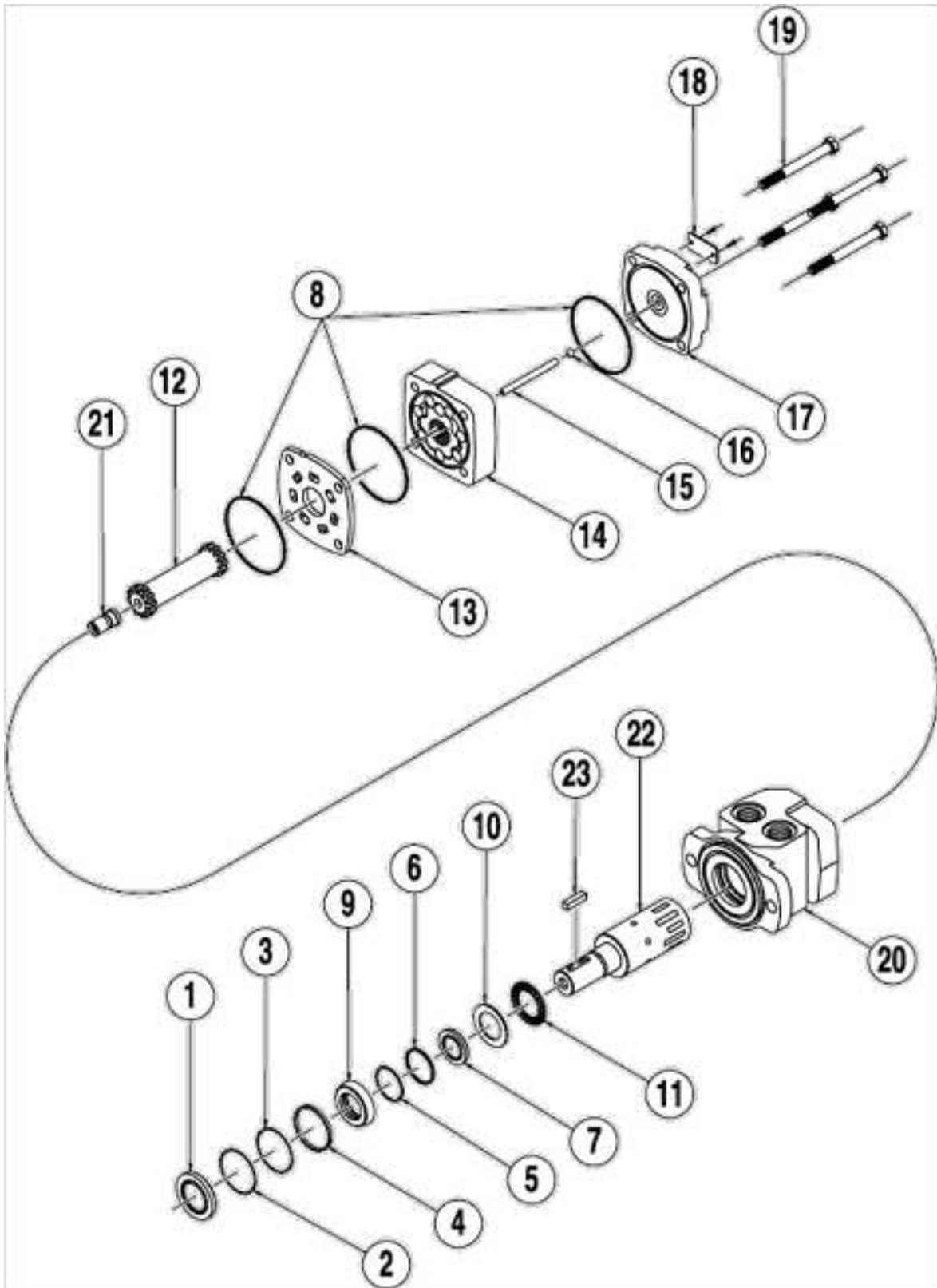

## 05006549 MOTOR ASSEMBLY PARTS LIST

Item	Part Number	Description
1	Seal Kit 05006061	Dust Seal
2		Split Wire Ring
3		Metal Backup Shim
4		High Pressure Seal
5		Metal Backup Shim
6		Teflon Backup Shim
7		Shaft Seal
8		Body Seals (3)
9		Seal Carrier
10		Thrust Washer
11	05006357	Thrust Bearing
12	05006366	Drive Link Kit
13	05006359	Wear Plate
14	05006082	Rotor Kit
15	05006081	Drive Link Pin Kit
16	---	Included in item #15 Drive Link Pin Kit
17	05006360	End Cover
18	---	Serial Number Plate
19	05006064	Bolt Set Kit
20	05006564	Housing Kit, 4-Hole, w/ 7/8" O-Ring
21	05006358	Cooling Plug
22	05006370	Shaft Kit, 1" Straight
23	05006371	Key Kit, 1" Straight

05006550 MOTOR, HYDRAULIC, WHITE, 6.3 CI, 4-BOLT

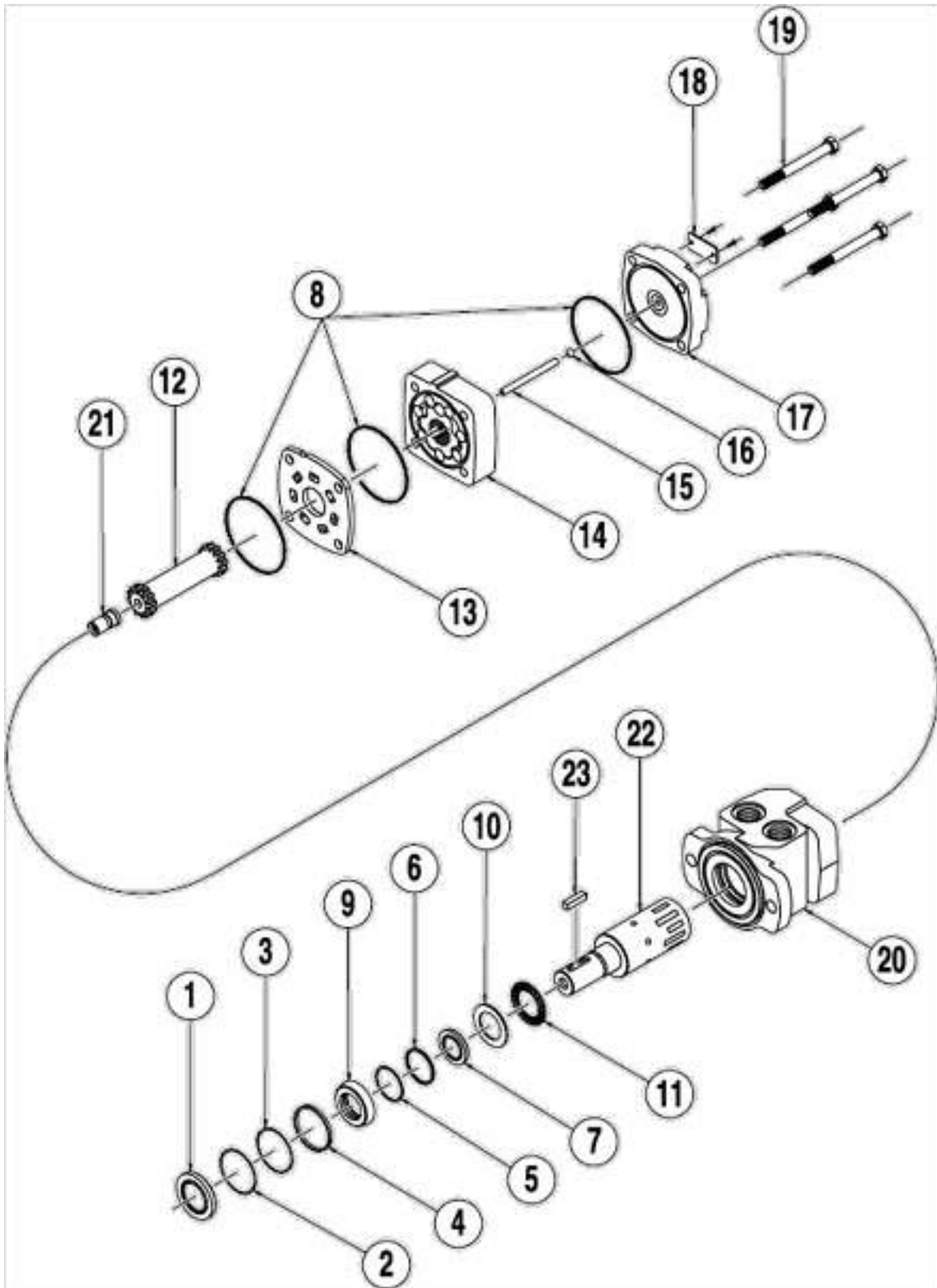

## 05006550 MOTOR ASSEMBLY PARTS LIST

Item	Part Number	Description
1	Seal Kit 05006061	Dust Seal
2		Split Wire Ring
3		Metal Backup Shim
4		High Pressure Seal
5		Metal Backup Shim
6		Teflon Backup Shim
7		Shaft Seal
8		Body Seals (3)
9		Seal Carrier
10		Thrust Washer
11	05006357	Thrust Bearing
12	05006574	Drive Link Kit
13	05006359	Wear Plate
14	05006573	Rotor Kit
15	05006575	Drive Link Pin Kit
16	---	Included in item #15 Drive Link Pin Kit
17	05006360	End Cover
18	---	Serial Number Plate
19	05006576	Bolt Set Kit
20	05006564	Housing Kit, 4-Hole, w/ 7/8" O-Ring
21	05006358	Cooling Plug
22	05006370	Shaft Kit, 1" Straight
23	05006371	Key Kit, 1" Straight

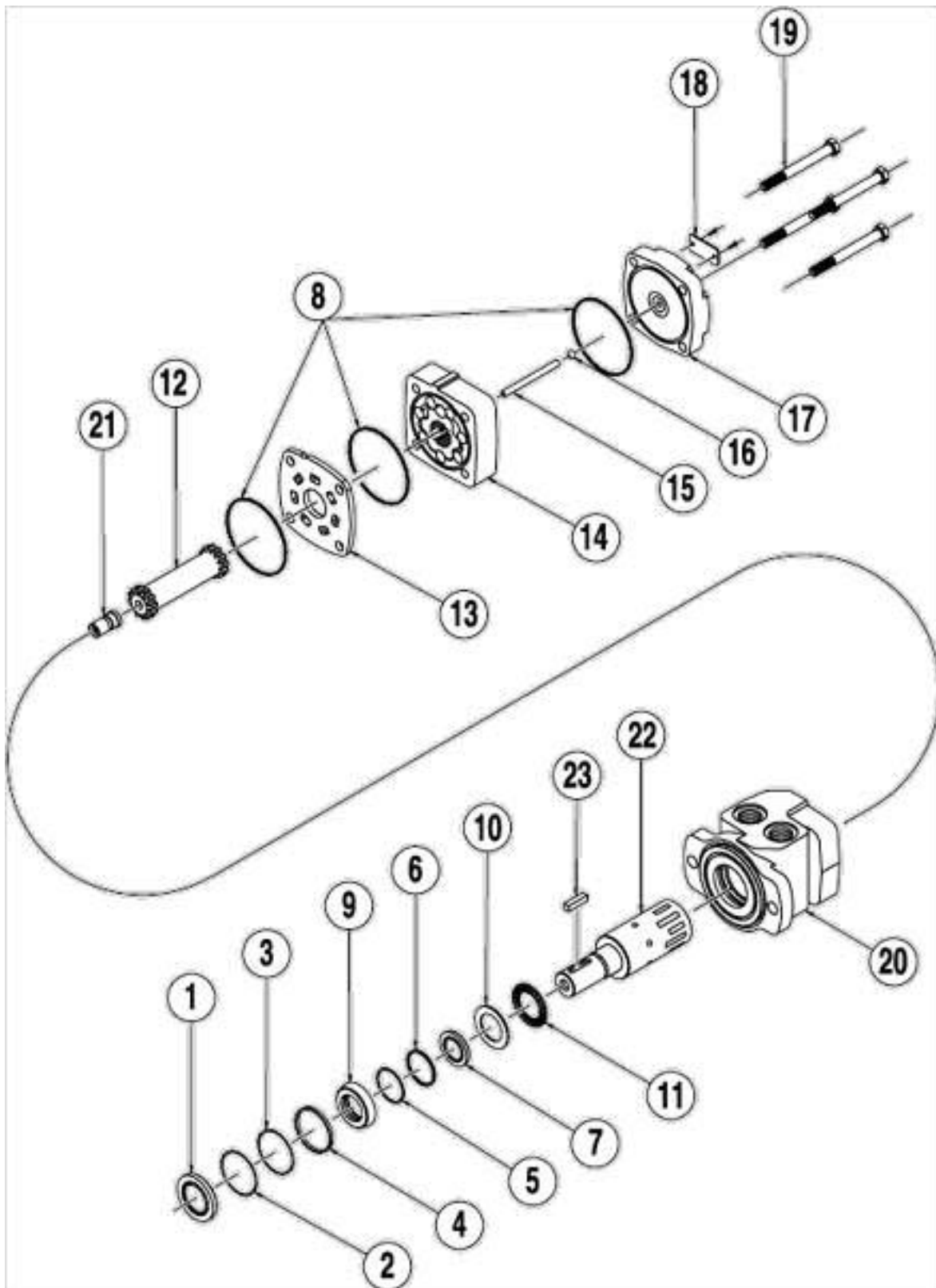

## MOTOR ASSEMBLY PARTS LIST

Item	Part Number	Description
1	Seal Kit 05006679	Dust Seal
2		Split Wire Ring
3		Metal Backup Shim
4		High Pressure Seal
5		Metal Backup Shim
6		Teflon Backup Shim
7		Shaft Seal
8		Body Seals (3)
9		Seal Carrier
10		Thrust Washer
11	05006357	Thrust Bearing
12	05006366	Drive Link Kit
13	05006359	Wear Plate
14	05006082	Rotor Kit
15	05006081	Drive Link Pin Kit
16	---	Included in item #15 Drive Link Pin Kit
17	05006360	End Cover
18	---	Serial Number Plate
19	05006576	Bolt Set Kit
20	05006564	Housing Kit, 2-Hole, w/ 7/8" O-Ring
21	05006358	Cooling Plug
22	05006410	Shaft Kit, 1" Straight Speed Sensor
23	05006371	Key Kit, 1" Straight Speed Sensor

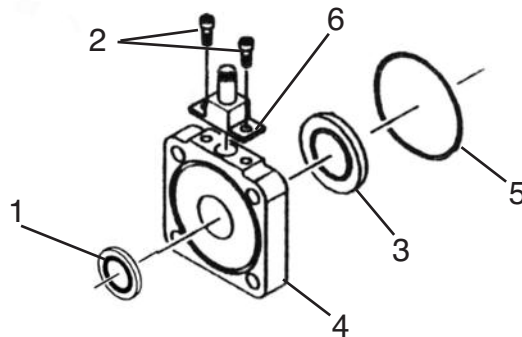

## SPEED SENSOR KIT

Item	Qty	Part Number	Description
1	1	05006560	Dust Seal
2	2	05006561	Sensor Attachment Screw
3	1	05006600	Sensor Magnet
4	1	05006418	4-Hole Sensor Flange
5	1	05006601	4-Hole Sensor Flange Seal
6	1	05006629	Speed Sensor ONLY - 100 Pulse



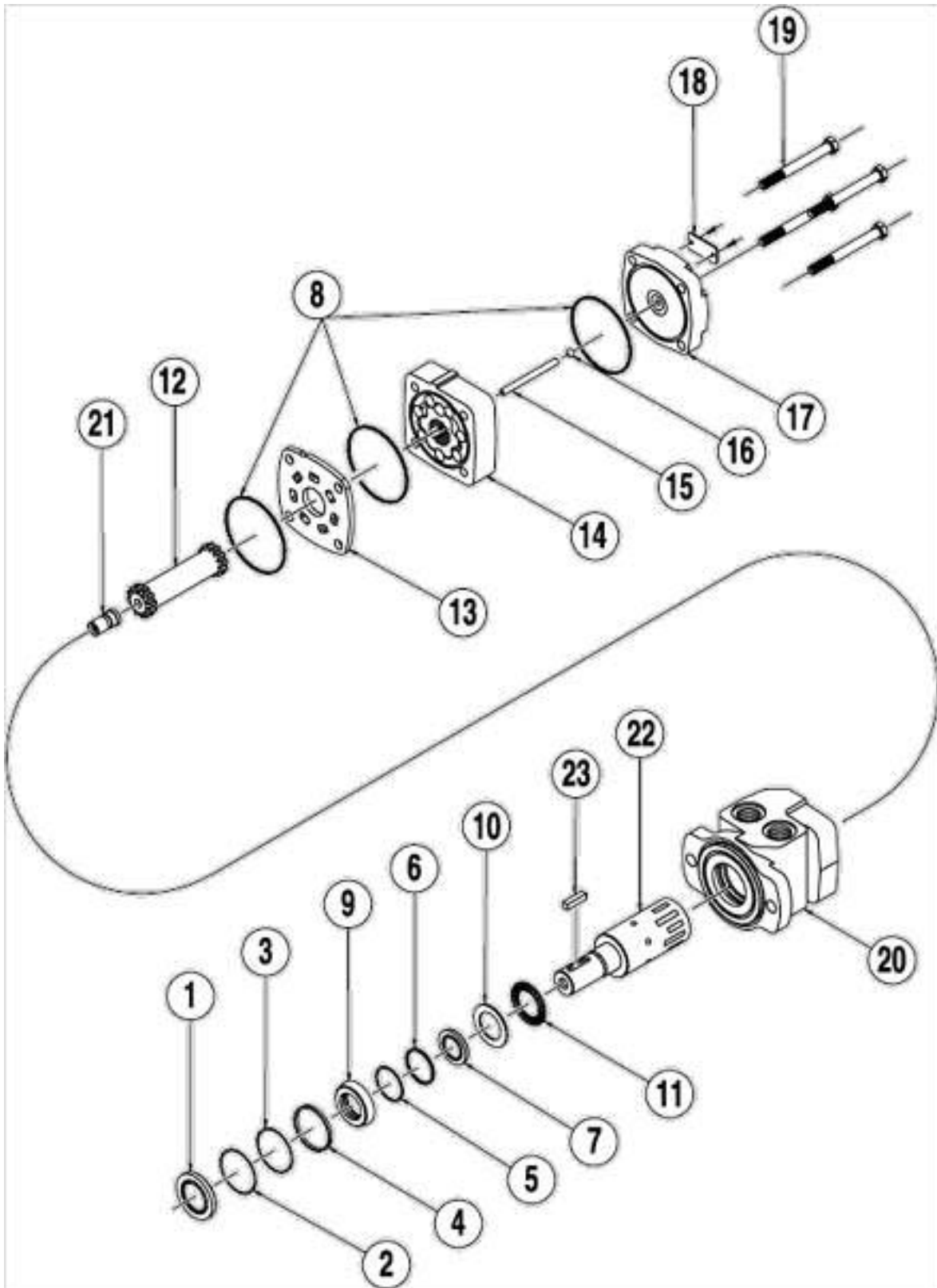

## MOTOR ASSEMBLY PARTS LIST

Item	Part Number	Description
1	Seal Kit 05006679	Dust Seal
2		Split Wire Ring
3		Metal Backup Shim
4		High Pressure Seal
5		Metal Backup Shim
6		Teflon Backup Shim
7		Shaft Seal
8		Body Seals (3)
9		Seal Carrier
10		Thrust Washer
11	05006357	Thrust Bearing
12	05006366	Drive Link Kit
13	05006359	Wear Plate
14	05006715	Rotor Kit
15	05006716	Drive Link Pin Kit
16	---	Included in item #15 Drive Link Pin Kit
17	05006360	End Cover
18	---	Serial Number Plate
19	05006717	Bolt Set Kit
20	05006564	Housing Kit, 4-Hole, w/ 7/8" O-Ring
21	05006358	Cooling Plug
22	05006410	Shaft Kit, 1" Straight Speed Sensor
23	05006371	Key Kit, 1" Straight Speed Sensor

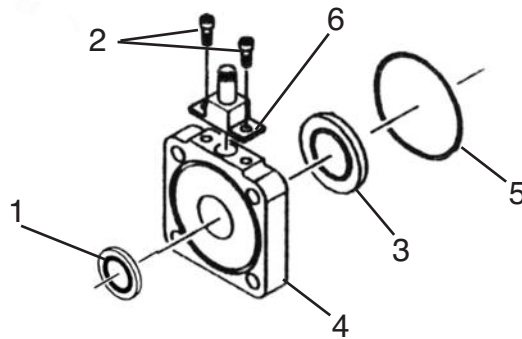

## SPEED SENSOR KIT

Item	Qty	Part Number	Description
1	1	05006560	Dust Seal
2	2	05006561	Sensor Attachment Screw
3	1	05006600	Sensor Magnet
4	1	05006418	4-Hole Sensor Flange
5	1	05006601	4-Hole Sensor Flange Seal
6	1	05006629	Speed Sensor ONLY - 100 Pulse

05006556 MOTOR, HYDRAULIC, WHITE, 24 CI, 4 BOLT

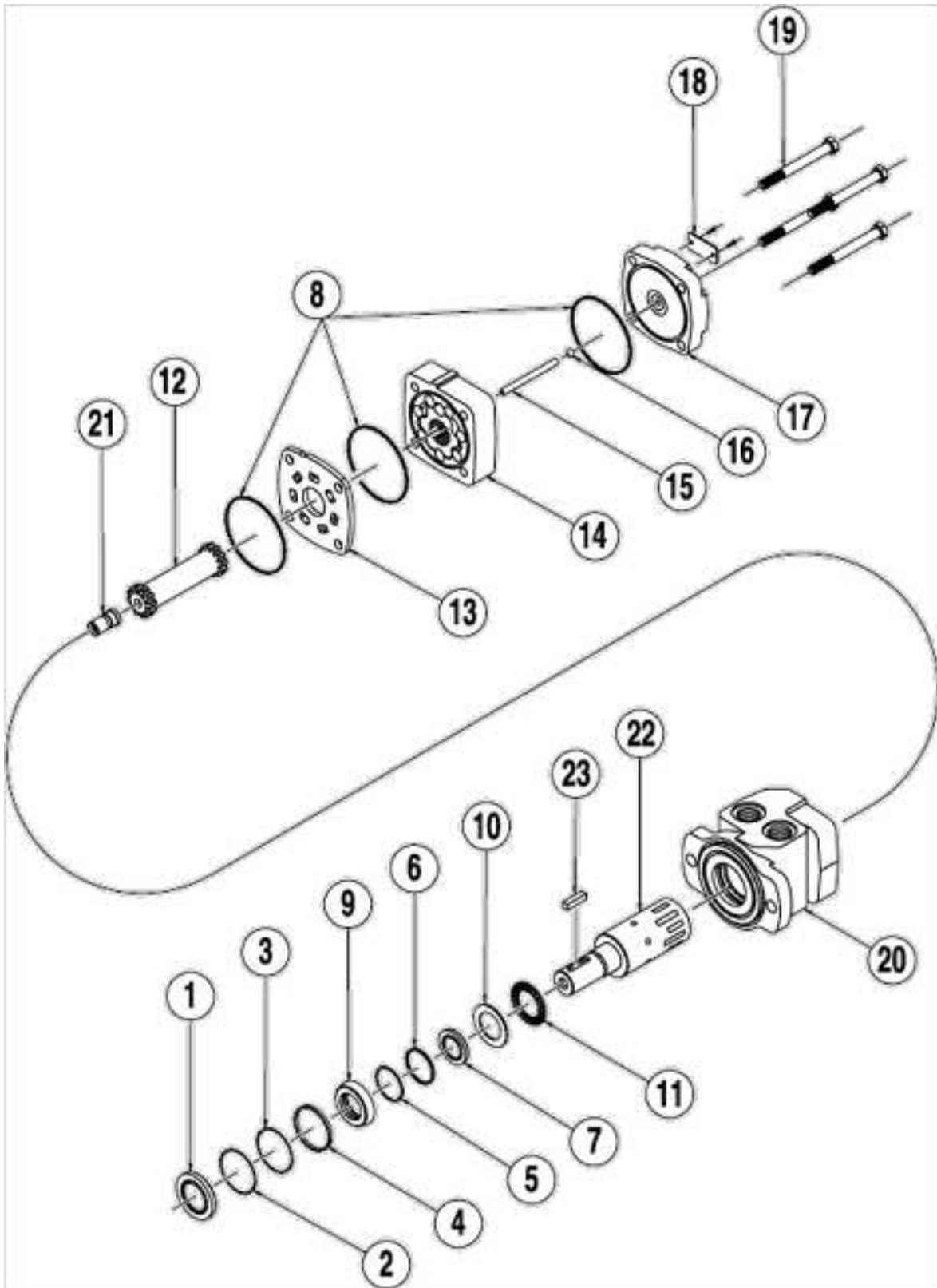

## 05006556 MOTOR ASSEMBLY PARTS LIST

Item	Part Number	Description
1	Seal Kit	Dust Seal
2		Split Wire Ring
3		Metal Backup Shim
4		High Pressure Seal
5		Metal Backup Shim
6		Teflon Backup Shim
7		Shaft Seal
8		Body Seals (3)
9		Seal Carrier
10		Thrust Washer
11	05006357	Thrust Bearing
12	05006366	Drive Link Kit
13	05006359	Wear Plate
14	05006365	Rotor Kit
15	05006367	Drive Link Pin Kit
16	---	Included in item #15 Drive Link Pin Kit
17	05006360	End Cover
18	---	Serial Number Plate
19	05006368	Bolt Set Kit
20	05006564	Housing Kit, 2-Hole, w/ 7/8" O-Ring
21	05006358	Cooling Plug
22	05006370	Shaft Kit, 1" Straight Speed Sensor
23	05006371	Key Kit, 1" Straight Speed Sensor

05006673 MOTOR, HYD, WHITE, 3.2CI, 4B, 1" EXT SHAFT, .875" ORB/SEAL SAVER

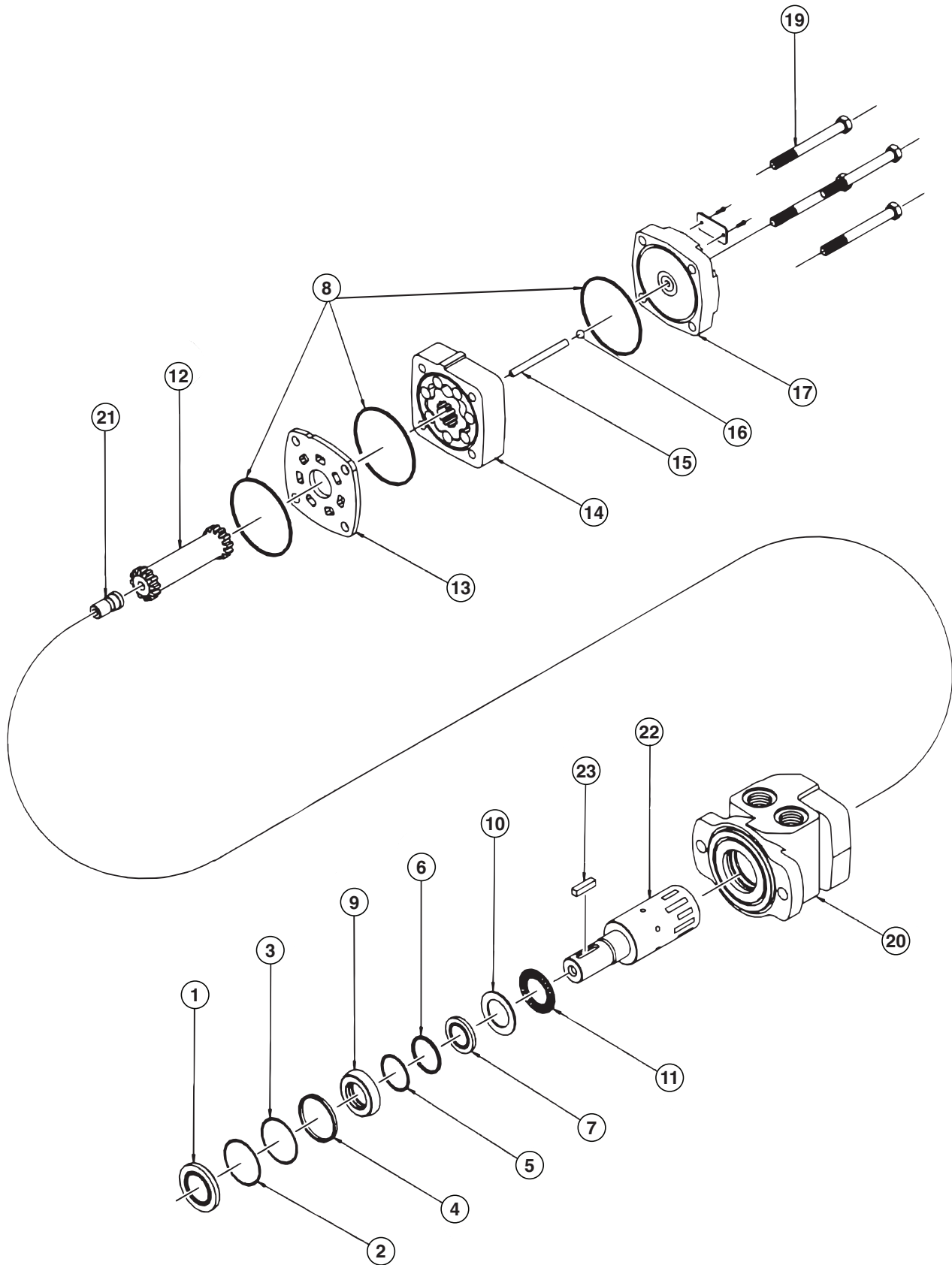

## MOTOR ASSEMBLY PARTS LIST

Item	Part Number	Description
1	Seal Kit 05006679	Dust Seal
2		Split Wire Ring
3		Metal Backup Shim
4		High Pressure Seal
5		Metal Backup Shim
6		Teflon Backup Shim
7		Shaft Seal
8		Body Seals (3)
9		Seal Carrier
10		Thrust Washer
11	---	Thrust Bearing
12	---	Drive Link Kit
13	---	Wear Plate
14	---	Rotor Kit
15	---	Drive Link Pin Kit
16	---	Included in item #15 Drive Link Pin Kit
17	---	End Cover
18	---	Serial Number Plate
19	---	Bolt Set Kit
20	05006564	Housing Kit, 4-Hole, w/ 7/8" O-Ring
21	---	Cooling Plug
22	05006410	Shaft Kit 1" Straight Speed Sensor
23	---	Key Kit, 1" Straight

05007338 GEARBOX, 5:1, 1.25" SHAFT DIA, 6" LG, 4B, SUPERIOR

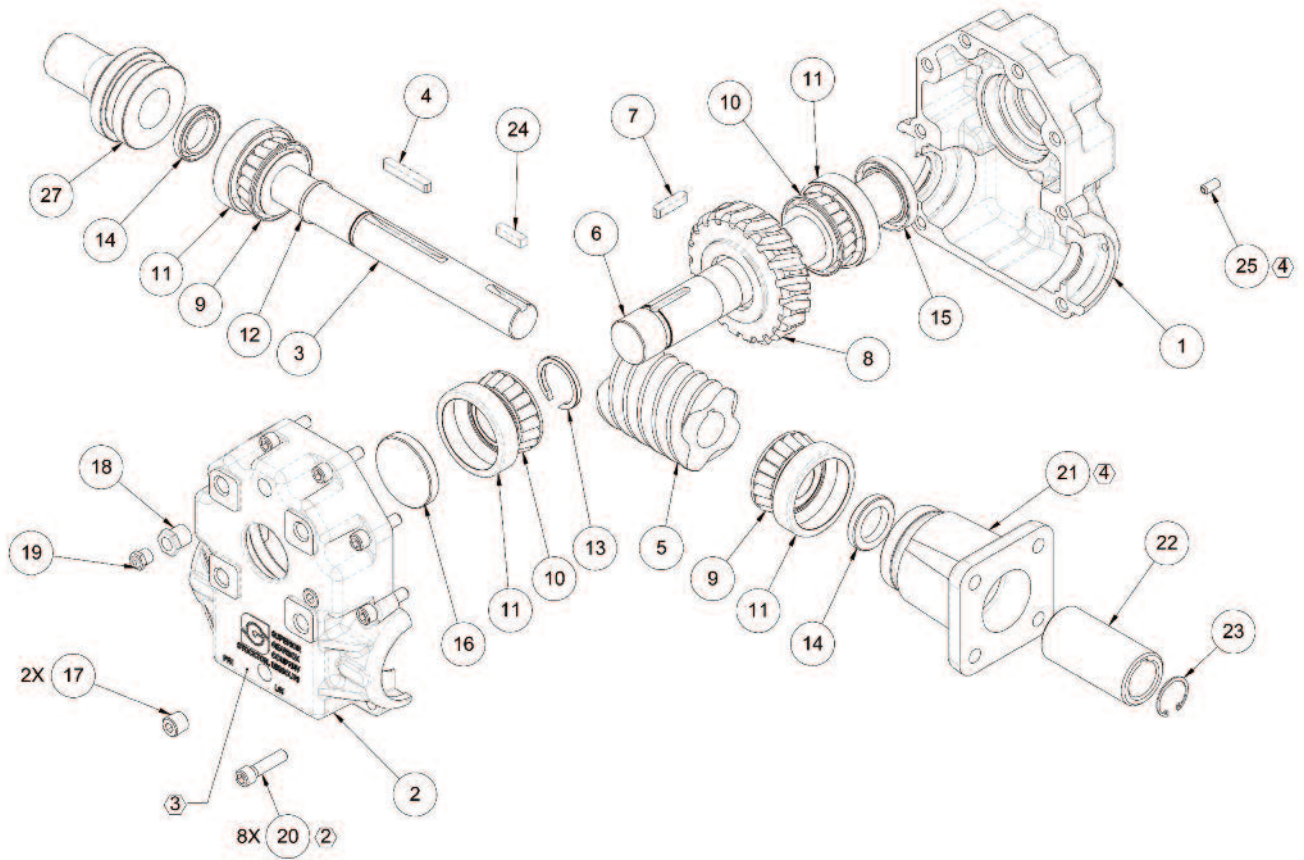

**05007338 GEARBOX, 5:1, 1.25" SHAFT, DIA, 6"**

Item	Qty	Part Number	Description
1	1	05007396	Shaft, Input
2	1	05007397	Housing, Machine, Tap Black
3	1	05007398	Housing, Machine
4	1	05007399	Gear, Worm
5	2	05007381	Bearing, Cone, 1
6	2	05007400	Shaft, Output
7	4	05007383	Bearing, Cup
8	1	05007081	Retaining Ring, Ext 1 Shaft
9	1	05007082	Retaining Ring, Ext 1.25 Shaft
10	1	05051110	Seal, 1-1.499-.25
11	1	05051140	Seal, 1.25-2-.312
12	1	05007384	Key, .25 x .25, 1.080
13	1	05007385	Key, .25 x .25, 1.580
14	5	05007386	Plug, .25-18 NPT
15	1	05007387	End Cap, 2.312-.313
16	1	05051136	End Cap, 2-.312
17	1	05007388	Bushing, .25 x .125
18	1	05007366	Plug, Vent
19	1	05007401	Bolt, .313-18 x 1.25, SHCS
20	8	05007402	Adapter, Hyd, 4-Bolt Mach Blk
21	1	05007083	Coupler
22	1	05007404	Retaining Ring
23	1	05007405	Key, .25 x .25
24	1	05007406	Adapter Pin
25	2	05007407	Gear, Worm Rolled
26	2	05007355	Assy, Adapter/Shaft Guard Worm
27	1	05007390	Zerk, Grease Spin Drive
28	14	05007372	Lube



# OPTIONAL EQUIPMENT

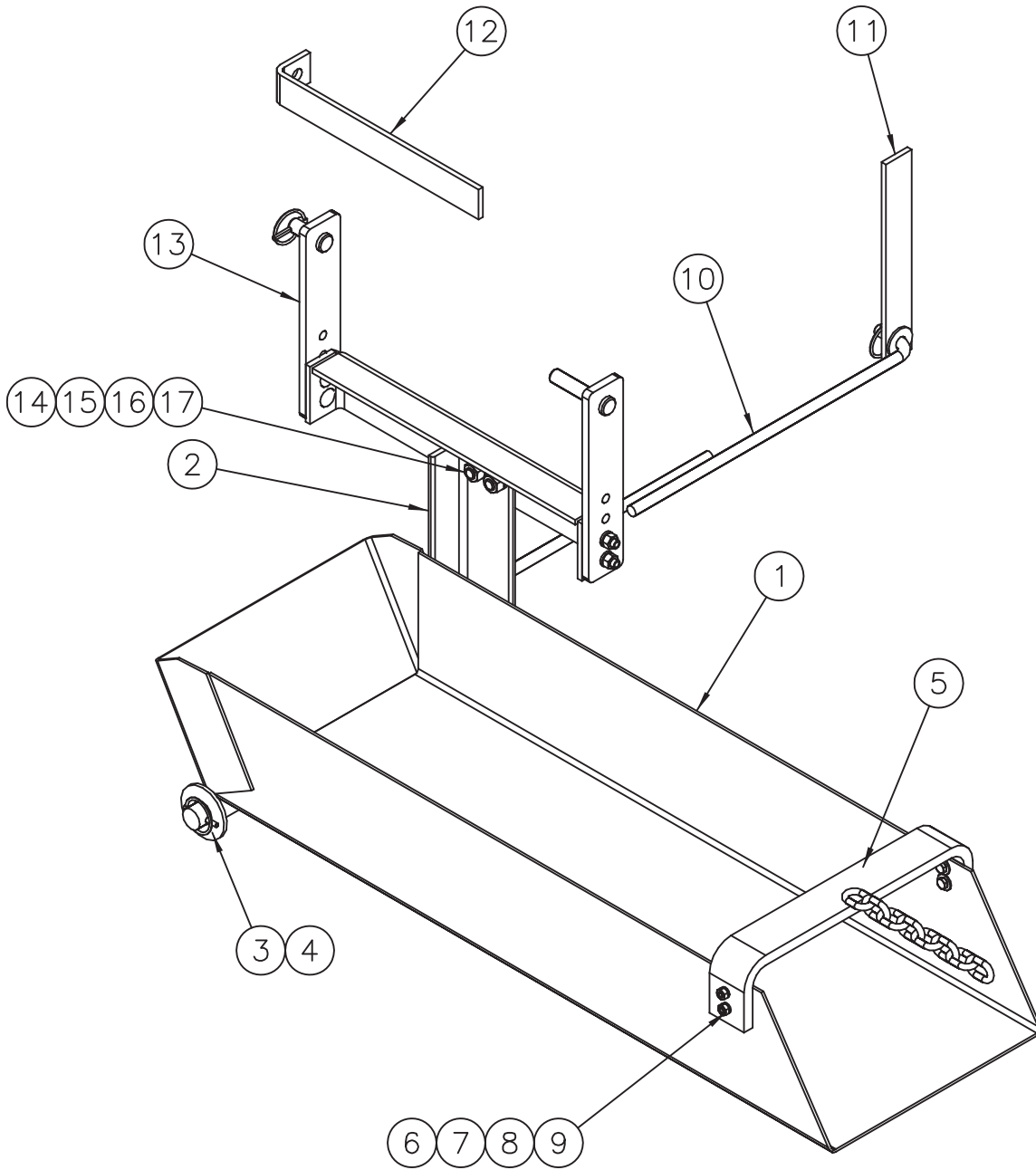

Item	Qty.	Part Number	Description
	1	00041247-A	CHUTE WLDMT,CENTERLINE,MS
	1	00041247-B	CHUTE WLDMT,CENTERLINE,304SS
	1	00041247-C	CHUTE WLDMT,CENTERLINE,UT,AUSST
	1	00041184-A	CL CHUTE BRKT WELDMENT MS
	1	00041184-B	CL CHUTE BRKT WELDMENT 304SST
	1	00041184-C	BRACKET WLDMT,CHUTE,CENTERLINE,AUSST
	4	05022106	PIN .188 LYNCH
	1	05021314	WASHER 1.00 FLAT ZC
	1	05021449	WASHER 1.00 FLAT SAE SS 18-8
	1	00105121-A	CROSS BAR WLDMT,CHUTE,CL,UT,MS
	1	00105121-B	CROSS BAR WLDMT,CHUTE,CL,UT,304
	4	05010593	BOLT .250-20 x 1.00 G8 HHCS ZC
	4	05016040	BOLT .250-20 x 1.00 HHCS SS
	4	05021363	WASHER .250 LOCK ZC
	4	05021393	WASHER .250 LOCK SS
	4	05021305	WASHER .250 FLAT ZC
	4	05021403	WASHER .250 FLAT SS
	4	05020264	NUT .250-20 G8 HEX ZC
	4	05020844	NUT .250-20 G8 HEX SS
0	2	00041156-A	STABILIZER ROD WLDMT,MS-UT,MS
0	2	00041156-B	STABILIZER ROD WLDMT,MS-UT,304
1	1	00041121-A	STABILIZER,SPINNER,MS-UT,MS
1	1	00041121-B	STABILIZER,SPINNER,MS-UT,304
2	1	00041124-A	BRACKET,STABILIZER,MS-UT,MS
2	1	00041124-B	BRACKET,STABILIZER,MS-UT,304
3	1	00103663-A	HANGER ASSY,SPINNER,TGT,MS
3	1	00103663-B	HANGER ASSY,SPINNER,TGT,304
4	2	05010690	BOLT .500-13 x 1.25 G8 HHCS ZC
4	2	05016045	BOLT .500-13 x 1.25 HHCS SS
5	2	05021005	WASHER .500 FLAT MIL-CARB SAE ZC
5	2	05021450	WASHER .500 FLAT SAE SS 18-8
5	2	05021367	WASHER .500 LOCK ZC
5	2	05021396	WASHER .500 LOCK SS
7	2	05020268	NUT .500-13 G8 HEX ZC
7	2	05020848	NUT .500-13 HEX SS

# DISCHARGE RATE

## MS966-TS CHAIN DRIVE

		<b>DISCHARGE RATE (CU. FT./MIN.)</b>		27 CU. FT. = 1 CU. YD.
<b>FLOW RATE (GPM)</b>	<b>0</b>	0.00	0.00	
	<b>1</b>	1.79	2.69	
	<b>2</b>	3.58	5.38	
	<b>4</b>	7.17	10.75	
	<b>6</b>	10.75	16.13	
	<b>8</b>	14.34	21.50	
	<b>10</b>	17.92	26.88	
	<b>12</b>	21.50	32.26	
	<b>14</b>	25.09	37.63	
	<b>16</b>	28.67	43.01	
	<b>18</b>	32.26	48.38	
	<b>20</b>	35.84	53.76	<b>MAX</b>
		<b>4</b>	<b>6</b>	
		<b>AUGER PITCH (IN.)</b>		

- NOTE:**
1. Data is for reference only. Calculations assume 100% efficiencies and are therefore theoretical.
  2. Rates vary with material type and moisture content.
  3. Calculations represent standard equipment configurations.

# MS966-TS DIRECT DRIVE

		<b>DISCHARGE RATE (CU. FT./MIN.)</b>	
<b>FLOW RATE (GPM)</b>	0	0.00	0.00
	1	1.87	2.81
	2	3.74	5.62
	4	7.49	11.23
	6	11.23	16.85
	8	14.98	22.46
	10	18.72	28.08
	12	22.46	33.70
	14	26.21	39.31
	16	29.95	44.93
	18	33.70	50.54
	20	37.44	56.16
		4	6
		<b>AUGER PITCH (IN.)</b>	

27 CU. FT. = 1 CU. YD.

**MAX**

- NOTE:**
1. Data is for reference only. Calculations assume 100% efficiencies and are therefore theoretical.
  2. Rates vary with material type and moisture content.
  3. Calculations represent standard equipment configurations.

# MS966-TS GEARBOX DRIVE

		<b>DISCHARGE RATE (CU. FT./MIN.)</b>		27 CU. FT. = 1 CU. YD.
		4	6	
<b>FLOW RATE (GPM)</b>	0	0.00	0.00	
	1	1.48	2.22	
	2	2.96	4.44	
	4	5.92	8.88	
	6	8.88	13.32	
	8	11.84	17.76	
	10	14.80	22.20	
	12	17.76	26.64	
	14	20.72	31.08	
	16	23.68	35.52	<b>MAX</b>
		<b>4</b>	<b>6</b>	
		<b>AUGER PITCH (IN.)</b>		

- NOTE:**
1. Data is for reference only. Calculations assume 100% efficiencies and are therefore theoretical.
  2. Rates vary with material type and moisture content.
  3. Calculations represent standard equipment configurations.

## HOW TO ORDER PARTS

To order or inquire about replacement parts, please contact the **distributor** or **store** that the product was purchased through. To speed the information flow, please have the following information ready:

- Model Number
- Serial Number
- Part Number and/or description as per the parts manual
- Quantity needed

For further information about **Monroe Truck Equipment** replacement parts, please call 877-834-9049 and ask for **Snow & Ice Parts Sales**.

## RETURN POLICY

Merchandise returned to **Monroe Truck Equipment** must have a Returned Goods Authorization (RGA) form filled out completely and signed by authorized personnel. To get your RGA form, call 800-880-0109. For whole goods, ask for **Snow & Ice Sales**. For replacement parts, ask for **Snow &**

**Ice Parts Sales**. All returned items are subject to a 15% restocking fee and

## MONROE TRUCK EQUIPMENT, INC. WARRANTY SNOW & ICE CONTROL PRODUCTS

**Monroe Truck Equipment, Inc.** warrants to the original purchaser, that if any part of the product proves to be defective in workmanship or material within **ONE YEAR** of the original installation, and is returned to us within 30 days of the discovered defect, we will (at our option) repair or replace the defective part. This warranty does not apply to damage resulting from misuse, neglect, accident, improper installation, normal wear items or lack of maintenance. This warranty is exclusive and supersedes all other warranties, whether expressed or implied. **Monroe Truck Equipment, Inc.** neither assumes, nor authorizes anyone to assume for it, any other obligation or liability in connection with this warranty and will not be liable for consequential damages.

All engines, pumps, motors, cylinders and valves are warranted by their manufacturer and not by **Monroe Truck Equipment, Inc.**. The manufacturer's warranty will apply to these parts. Electrical and hydraulic components are not to be disassembled without the express written permission of Monroe Truck Equipment. Use of replacement parts other than original equipment voids this warranty.

All defective parts returned must be accompanied by the model number, serial number, date installed, date of defect, description of defect, and the name of the distributor from whom it was purchased. All warranty claims must have prior written approval from **Monroe Truck Equipment, Inc.**

***Please return the warranty registration card that accompanies this manual to confirm receipt of this parts catalog and acknowledge the information contained within. Failure to return the attached card may result in a voided warranty.***



**1051 West 7<sup>th</sup> Street  
 Monroe, WI 53566  
 608-328-8127 ~ Fax: 608-328-4278**

## Warranty Policy Uninstalled Parts and Equipment Provided by Monroe Truck Equipment

Monroe Truck Equipment will provide the following limited warranty for a period of one year to the original purchaser of all uninstalled goods provided by Monroe Truck Equipment:

**LIMITED WARRANTY:** All goods provided by Monroe Truck Equipment (MTE) will be free from defects in material and workmanship for a period of one year from the date of purchase by the original purchaser. This limited warranty shall be the sole and exclusive remedy for any such product found to be defective. This limited warranty supercedes all previous warranties and is exclusive and in lieu of all other warranties, whether expressed or implied.

This limited warranty applies only to parts or accessories manufactured by MTE and/or provided by same. Except with respect to title, this limited warranty does not pertain to parts or accessories not manufactured and/or provided by MTE, regardless of whether such parts or accessories were selected and/or recommended by MTE. MTE will, as a service to the buyer, pass on any warranties received from the original manufacturer of MTE provided parts and/or accessories.

MTE will not under any circumstances be liable for any incidental or consequential damages whether in tort, contract, or otherwise, for any bodily injury, death, property damage, loss of use, or loss of income resulting from or in any way arising out of any goods provided by MTE, or their sale, use, or manufacture.

Any warranty claim deemed to be arising from the result of misuse, abuse, neglect, accident, improper installation, lack of maintenance, act of war (whether declared or otherwise), or act of God will be denied. Any repair or modification by the buyer or any third party, without the prior written consent of MTE, will void any possible warranty compensation. Any damage deemed to be the result of abnormal operation will not be compensated by this warranty.

Normal or special maintenance items such as fuels, fluids, tires, belts, hoses, filters, air cleaners, light bulbs, and any other items subject to normal wear and tear that are supplied in connection with goods provided by MTE are not allowed under this warranty.

All engines, pumps, cylinders, valves, and motors are warranted by their manufacturer and not by Monroe Truck Equipment. The manufacturer's warranty will apply to these parts. Electrical and hydraulic components are not to be disassembled without the express written consent of MTE. Any disassembly of MTE provided components without prior authorization will void the applicable warranty.

Monroe Truck Equipment shall be the sole and final determining authority as it applies to the administration of this warranty policy. Purchaser acknowledges receipt of Monroe Truck Equipment Warranty Policy and agrees to be bound by same.



### GLOBAL SOLUTIONS

ARMORED VEHICLES ~ SPORT TRUCK CONVERSIONS  
 MUNICIPAL SNOW & ICE CONTROL ~ FIRE APPARATUS  
 PICKUP TRUCK ACCESSORIES ~ TRUCK EQUIPMENT/MODIFICATIONS







**1051 West 7<sup>th</sup> Street  
 Monroe, WI 53566  
 608-328-8127 ~ Fax: 608-328-4278**

Any and all warranty claims must be forwarded to MTE within 10 days of defect discovery. A copy of the original Monroe Truck Equipment invoice as well as the manufacturer's model number, serial number, and date of installation must accompany all correspondence regarding said claims. MTE will, at their option, choose whether to repair or replace the defective part unless otherwise specified by the original manufacturer of said part.

**Procedures for Warranty Claims Notification**

For submission of any warranty claim please contact Monroe Truck Equipment – Warranty Department at 800-356-8134

The following documentation will be needed when you call for initial warranty authorization:

1. A copy of the original MTE invoice.
2. Make, Model, and VIN or Serial Number of the equipment involved.
3. Part number and serial number of the part in question.
4. A complete description of the problem.

The following must accompany any claims submitted to Monroe Truck Equipment:

1. Documented photographs of any physical damage.
2. Inspection notes by MTE personnel or MTE authorized 3<sup>rd</sup> party.
3. Authorization number issued by Monroe Truck Equipment – Warranty Department.

Defective parts must be returned to Monroe Truck Equipment (freight prepaid) within 30 days of issuance of Authorization Number.

Monroe Truck Equipment reserves the right to void any warranty for failure to comply with Monroe Truck Equipment Warranty Policy.

This policy is effective October 11, 2012



